

## **Appendix 23**

---

### **Whale Tail Mine Incinerator and Composter Waste Management Plan Version 3**

---



**AGNICO EAGLE**

**WHALE TAIL MINE**

Whale Tail Mine –  
Incinerator and Composter  
Waste Management Plan

---

**APRIL 2025**

**VERSION 3**

## EXECUTIVE SUMMARY

---

This Incinerator and Composter Waste Management Plan (ICWMP) describes the performance limits, waste management protocols, operation, monitoring, and reporting requirements for the proposed incinerator, composter and used oil burning furnaces. This ICWMP will be maintained by Agnico Eagle to reflect the current operations, permit requirements and regulatory setting. The ICWMP will be reviewed on a regular basis and revised by Agnico Eagle when necessary.

The main objective of waste management relating to the incinerator, used oil furnaces, and composter is to minimize the amount of solid waste to be incinerated by implementing an effective waste segregation and composting program to ensure that only appropriate types of waste are incinerated. The primary objective of incineration is to reduce the volume of burnable waste to manage the day-to-day waste generated on-site. The composting of organic waste generated at the Whale Tail camp provides an alternative to incineration that is expected to reduce overall emissions.

The proposed incinerator will be a dual chamber, high-temperature incinerator and will be used to dispose of solid waste from the accommodation camp, kitchen, shops, and offices that cannot be composted or landfilled. The materials to be incinerated will be limited to wood and food packaging. It will be designed to ensure the emissions meet Canadian Council of Ministers of the Environment (CCME) Canada-wide Standards (CWS) for Dioxin and Furans (CCME, 2001a) and the CCME CWS for Mercury Emissions (CCME, 2000). In addition to the incinerator technology, the implementation of a waste management and segregation plan will further limit emissions of mercury and dioxins and furans from the incinerator. Compliance with the performance limits will be confirmed by stack testing.

Ash produced from the incineration process will be disposed of in the on-site landfills provided it meets criteria as stated in Industrial Waste Discharges into Municipal Solid Waste and Sewage Treatment Facilities (GN, 2011a). A protocol will be implemented for testing incinerator ash and contingent measures for alternate disposal of ash if quality is unsuitable for landfilling.

Small used oil burning furnaces are proposed to be utilized to recycle used petroleum products such as heavy lubricants and engine oil.

The composter consists of an insulated cylinder that rotates according to pre-set timed intervals. Key performance indicators such as temperature and humidity are determined with the composter supplier.

The quantity and type of materials incinerated and composted on-site during operations, together with results from periodic stack emissions, used oil and ash monitoring, will be included in the annual report.

## **IMPLEMENTATION SCHEDULE**

As required by Water License 2AM-WTP1830, Part B, Item 11, the proposed implementation schedule for this Plan is outlined below.

This Plan will be implemented immediately (April 2025) subject to any modifications proposed by the NWB as a result of the review and approval process. This document will supersede the Incinerator and Composter Waste Management Plan Version 2 – 2023.

## **DISTRIBUTION LIST**

Agnico Eagle – General Mine Manager

Agnico Eagle – Environment and Critical Infrastructures Superintendent

Agnico Eagle – Environmental General Supervisor

Agnico Eagle – Environmental Coordinator

Agnico Eagle – Environmental Technician

Agnico Eagle – Energy and Infrastructures Superintendent

Agnico Eagle – Field Services Supervisor

Agnico Eagle – Incinerator Operator

Agnico Eagle – Composter Operator

**TABLE OF CONTENTS**

**EXECUTIVE SUMMARY ..... I**

**TABLE OF CONTENTS..... III**

**DOCUMENT CONTROL ..... V**

**ACRONYMS..... VI**

**SECTION 1 • INTRODUCTION..... 1**

    1.1 PROJECT OVERVIEW..... 1

**SECTION 2 • BACKGROUND INFORMATION ..... 3**

    2.1 LOCATION ..... 3

    2.2 INCINERATOR ..... 3

**FIGURE 2-1 COMPOSTER AND PROPOSED INCINERATOR LOCATION FOR WHALE TAIL MINE ..... 4**

    2.3 COMPOSTER ..... 5

    2.4 USED OIL AND WASTE FUEL ..... 5

**SECTION 3 • REGULATORY SETTING ..... 6**

    3.1 INCINERATOR ..... 6

    3.2 INCINERATOR ASH ..... 6

    3.3 COMPOSTER ..... 7

    3.4 USED OIL AND WASTE FUEL ..... 7

**SECTION 4 • PERFORMANCE LIMITS & MONITORING ..... 8**

    4.1 INCINERATOR SELECTION ..... 8

    4.2 INCINERATOR ASH ..... 8

**TABLE 4-2: GUIDELINES FOR SOLID WASTE/PROCESS RESIDUALS SUITABLE FOR LANDFILL ..... 9**

    4.3 COMPOSTER ..... 9

    4.4 USED OIL AND WASTE FUEL ..... 10

**TABLE 4-3 SUMMARY OF USED OIL AND WASTE FUEL REGULATIONS..... 10**

**TABLE 4-4 USED OIL IMPURITY LIMIT ..... 11**

**SECTION 5 • INCINERATOR AND COMPOSTER SPECIFICATIONS AND OPERATIONS ..... 12**

    5.1 INCINERATOR ..... 12

        5.1.1 SPECIFICATIONS..... 12

        5.1.2 OPERATION PROCEDURES ..... 12

        5.1.3 EMISSIONS ..... 13

        5.1.4 DUST/ODOUR CONTROL MEASURES..... 13

        5.1.5 STAFFING AND EQUIPMENT ..... 13

        5.1.6 OPERATOR TRAINING ..... 14

        5.1.7 INSPECTIONS..... 14

    5.2 COMPOSTER ..... 14

        5.2.1 SPECIFICATIONS..... 14

        5.2.2 OPERATION PROCEDURES ..... 15

        5.2.3 ODOUR CONTROL MEASURES..... 15

5.2.4 INTRODUCTION OF INVASIVE SPECIES .....	16
5.2.5 OPERATOR TRAINING .....	16
5.2.6 INSPECTIONS.....	16
5.3 USED OIL AND WASTE FUEL .....	16
5.4 CLOSURE PLAN.....	16
<b>SECTION 6 • WASTE MANAGEMENT .....</b>	<b>17</b>
6.1 APPROACH .....	17
6.2 ACCEPTABLE WASTE FOR INCINERATION.....	17
6.3 ACCEPTABLE WASTE FOR COMPOSTING.....	17
6.4 UNACCEPTABLE WASTE FOR INCINERATION.....	17
6.5 UNACCEPTABLE WASTE FOR COMPOSTING .....	18
6.6 WASTE VOLUMES.....	18
6.6.1 SOLID WASTE, INCINERATOR ASH, AND COMPOST .....	18
6.6.2 USED OIL AND WASTE FUEL .....	19
6.7 WASTE INCINERATION RATE .....	19
<b>FIGURE 6-1: PROCESS FLOW CHART FOR WASTE INCINERATION AND COMPOST .....</b>	<b>20</b>
<b>SECTION 7 • MONITORING AND TESTING.....</b>	<b>21</b>
7.1 INCINERATOR EMISSIONS AND TESTING .....	21
7.2 INCINERATOR ASH .....	21
7.3 COMPOST .....	21
7.4 USED OIL/WASTE FUEL TESTING.....	21
<b>SECTION 8 • REPORTING .....</b>	<b>23</b>
8.1 NATIONAL POLLUTANT RELEASE INVENTORY .....	23
<b>TABLE 8-1 NATIONAL POLLUTANT RELEASE INVENTORY INCINERATION REPORTABLE SUBSTANCE LIST.....</b>	<b>23</b>
8.2 GREENHOUSE GAS EMISSIONS AND GLOBAL WARMING.....	23
<b>SECTION 9 • PLAN REVIEW AND ADAPTIVE MANAGEMENT .....</b>	<b>24</b>
<b>REFERENCES .....</b>	<b>25</b>

**DOCUMENT CONTROL**

---

Version	Date	Section	Page	Revision
1_NIRB	October 2018			Incinerator and Composter Waste Management Plan as Supporting Document submitted to Nunavut Impact Review Board for review and approval as part of Whale Tail Pit – Expansion Project
1_NWB	April 2019			Incinerator and Composter Waste Management Plan as Supporting Document submitted to Nunavut Water Board for review and approval as part of Whale Tail Pit – Expansion Project
2	June 2023	1.1	1	Project overview updated.
		Figure 2-1	4	Figure updated to include locations of incinerator and composter.
		5.2.1		Composter specifications updated.
3	April 2025	1.1	1	Project overview updated.
		Figure 2-1	4	Figure updated with new satellite image.
		3.1	6	References updated
		4.1	8	Stack testing frequency updated.
		6.6	18	Projected waste volumes updated.
		References	25	References updated

Approved by:



Eric Haley

Environmental and Critical Infrastructures Superintendent

## ACRONYMS

---

Agnico Eagle	Agnico Eagle Mines Limited
CCME	Canadian Council of Ministers of the Environment
CEPA	Canadian Environmental Protection Act
CWS	Canada-Wide Standards
ECCC	Environment and Climate Change Canada
GN	Government of Nunavut
ICWMP	Incinerator and Composter Management Plan
NIRB	Nunavut Impact Review Board
NWB	Nunavut Water Board
TSF	Tailings Storage Facility

## SECTION 1 • INTRODUCTION

---

### 1.1 Project Overview

This Incinerator and Composter Waste Management Plan (ICWMP) describes the performance limits, waste management plans, operation, monitoring, and record keeping requirements for the primary incinerator, on-site waste oil burning furnaces, and composter.

This update to the June 2023 Incinerator and Composter Waste Management Plan (Version 2) is a component of the Whale Tail Environmental Management System. At present, there is no incinerator at the Whale Tail Mine, however Agnico Eagle will retain the possibility to construct an incinerator, following all requirements detailed as part of the Project Certificate No. 008 and 2AM-WTP1830 Water License, in the future if needed.

Domestic waste that is suitable for compost will follow the protocol outlined in Appendix II, however all other domestic waste will be collected and shipped off site during the annual barge season to an accredited external handling facility for appropriate disposal.

Should the incinerator begin operations, the objectives of this Plan are summarized as follows:

1. To define the operating procedures to be used in the incineration of appropriate non-hazardous solid waste generated at the Whale Tail Mine;
2. To define acceptable/non-acceptable types of solid waste to be placed in the Whale Tail incinerator; and
3. To define operating and monitoring requirements for the incinerator and waste oil burning furnaces.

This document presents the Incinerator and Composter Waste Management Plan (ICWMP) for the Mine. The Plan is divided into the following components:

- introductory section (Section 1);
- background and objectives (Section 2);
- summary of the regulatory setting (Section 3);
- description of the performance limits (Section 4);
- summary description of waste infrastructures operations (Section 5);
- outline of the waste management processes (Section 6);
- description of the proposed monitoring and testing (Section 7);
- overview of the proposed reporting to the authorizing agencies (Section 8); and
- plan review and adaptive management (Section 9).

The purpose of the Plan is to provide consolidated information on the specifications, operation, management, monitoring, and reporting of the incinerator, composter and used oil burning furnaces

processes proposed for the Mine. This Plan will be reviewed and updated on a regular basis to reflect changes to the Mine.

## SECTION 2 • BACKGROUND INFORMATION

---

At the Mine site, all waste will be safely managed from the time it is produced to final disposal. All waste will be segregated at the mine site and will predominately be landfilled, incinerated, composted, or recycled. Used oil burning will be maximized as much as possible using the secondary chamber of the incinerator. Remaining waste, including hazardous waste, will be packaged for shipment to a certified waste management facility for treatment, recycling, and/or disposal.

### 2.1 Location

The incinerator and composter will be located in separate buildings on the south end of the infrastructure pad, at least 100 meters away from any surface water body, downwind of other mine infrastructure, and away from the accommodations complex (see Figure 2-1 for both locations).

### 2.2 Incinerator

Polychlorinated dibenzo-p-dioxins and polychlorinated dibenzofurans, commonly known as dioxins and furans, are toxic, persistent, and bioaccumulative chemicals. Their presence in the environment results predominantly from human activity. The biggest source of dioxins and furans in Canada is the large-scale burning of municipal and medical waste.

Due to their environmental persistence and ability to accumulate in biological tissues, dioxins and furans are slated for virtual elimination under the Canadian Environmental Protection Act (CEPA), the Environment and Climate Change Canada (ECCC) Toxic Substances Management Policy (ECCC 2004) and the Canada Council of Ministers of the Environment (CCME) *Policy Statement for the Management of Toxic Substances* (CCME 1998).

Mercury is a naturally occurring substance, which can be transformed through biological processes to methyl mercury, a persistent substance which bioaccumulates in the food chain and is particularly toxic to humans and wildlife. Mercury levels originate from a combination of naturally occurring mercury and anthropogenically emitted mercury, essentially through combustion processes.

Under a variety of regional, national, bi-national, and internal programs, treaties and agreements, mercury is being targeted for emissions reductions consistent with the CCME *Policy Statement for the Management of Toxic Substances* (CCME 1998), which identifies that mercury shall be managed through its lifecycle to minimize release.

Figure 2-1 Composter and Proposed Incinerator Location for Whale Tail Mine



### 2.3 Composter

The incineration process utilizes fuel for its operation. Diverting organic material to the composting operation instead will result in a potential reduction in fuel consumption for the incinerator of approximately 1,500 litres of fuel per day and has the potential of reducing greenhouse gas emissions and atmospheric pollutants associated with incineration.

Composting the material will also provide an environmental benefit by reducing the amount of material being incinerated. The type of material that will be diverted from the incinerator to the composter coincidentally also has higher water content and takes longer to incinerate which will help to further reduce greenhouse gas emissions at the Whale Tail Mine site.

### 2.4 Used Oil and Waste Fuel

The following definitions are provided in the *Used Oil and Waste Fuel Management Regulations* (NWT, 2005).

**Used oil:** Any oil, including lubrication oil, hydraulic fluids, metal working fluid, and insulating fluid, that is unsuitable for its intended purpose due to the presence of impurities or the loss of original properties, but does not include used oil derived from animal or vegetable fat, a petroleum product spilled on land or water, or waste from a petroleum refining operation.

**Waste fuel:** A flammable or combustible petroleum hydrocarbon, with or without additives, that is unsuitable for its intended purpose due to the presence of contaminants or the loss of original properties, and includes gasoline, diesel fuel, aviation fuel, kerosene, naphtha, and fuel oil, but does not include paint, solvent, or propane.

## SECTION 3 • REGULATORY SETTING

---

### 3.1 Incinerator

Solid waste incinerators are regulated in Nunavut under the Nunavut Public Health Act, the Nunavut Environmental Protection Act, and the federal Environmental Protection Act. Various regulations and guidelines under these Acts, as well as guidelines developed by the CCME and technical documents developed by ECCC, were reviewed in preparing the ICWMP. They are as follows:

- CEPA (Minister of Justice (MOJ), 1999)
  - o Schedule 1: List of Toxic Substances
  - o *Cross-border Movement of Hazardous Waste and Hazardous Recyclable Material Regulations (MOJ, 2021)*
- ECCC Technical Document for Batch Waste Incineration (ECCC, 2010)
- ECCC Solid Waste Management for Northern and Remote Communities: Planning and Technical Guidance Document (ECCC, 2017)
- Canada-Wide Standard for Dioxins and Furans (CCME, 2001a)
- Canada-Wide Standard for Mercury (CCME, 2000)
- Nunavut *Environmental Protection Act*
  - o Environmental Guideline for Mercury-Containing Products and Waste Mercury (GN, 2010)
  - o Environmental Guideline for Industrial Waste Discharges into Municipal Solid Waste and Sewage Treatment Facilities (GN, 2011a)
  - o Environmental Guideline for the Burning and Incineration of Solid Waste (GN 2012)
  - o Environmental Guideline for Ambient Air Quality (GN, 2023a)
  - o Environmental Guideline for General Management of Special and Hazardous Waste (GN, 2023b)
- Nunavut *Public Health Act*

Provincial and/or territorial regulations that pertain to emissions from incinerators were not found for Nunavut or the Northwest Territories. Therefore, performance limits for the incinerator at the Mine will be in accordance with the emission guidelines set out by the CCME: Canada-Wide Standard (CWS) for Dioxins and Furans (CCME 2001a), and CWS for Mercury Emissions (CCME 2000).

### 3.2 Incinerator Ash

Ash produced from the incineration process will be disposed of according to the Nunavut Environmental Guideline for Industrial Waste Discharges into Municipal Solid Waste and Sewage Treatment Facilities (GN, 2011a).

### 3.3 Composter

In preparing this Plan, Agnico Eagle reviewed the following documents:

- Nunavut *Environmental Protection Act*
- ECCC Solid Waste Management for Northern and Remote Communities: Planning and Technical Guidance Document (ECCC, 2017)

Agnico Eagle initially plans to place the final compost product from the composting process into the on-site landfill but may explore other potential uses of the compost product in the future. In Nunavut, there are no regulations or guidelines specific to the quality or uses of compost product, however, guidelines for compost quality and categorization exist in other provinces and at the federal level. Should Agnico Eagle wish to employ compost for other potential uses, this management plan will be updated to incorporate relevant guidelines.

### 3.4 Used Oil and Waste Fuel

The management of used oil is regulated in the Northwest Territories through the *Used Oil and Waste Fuel Management Regulations* (NWT, 2005). In the absence of Nunavut guidelines/regulations pertaining to used oil and waste fuel, the Northwest Territories regulations will be followed for the Mine.

**SECTION 4 • PERFORMANCE LIMITS & MONITORING**

**4.1 Incinerator Selection**

The Mine will select and operate its incinerator based on ECCC’s *Technical Document for Batch Waste Incineration* (ECCC, 2010). The incinerator will comply with the guidelines listed in Table 4-1, where the maximum emissions are expressed as a concentration in the exhaust gas exiting the facility’s stack. The specifications of a potential incinerator are available in Appendix I. In addition to incinerator technology, the implementation of a waste segregation program will limit emissions of dioxins and furans, and mercury from the incinerator.

**Table 4-1 Emission Standards for Solid Waste Incinerators**

Emissions	Sector	Units	Guideline Maximum	Reference
Dioxins and Furans	Municipal Waste	pg I-TEQ/m <sup>3</sup>	80	CCME, CWS 2001a
Dioxins and Furans	Sewage Sludge Incineration	pg I-TEQ/m <sup>3</sup>	80	CCME, CWS, 2001a
Mercury	Municipal Waste	µg/R m <sup>3</sup>	20	CCME, CWS, 2000
Mercury	Sewage Sludge Incineration	µg/R m <sup>3</sup>	70	CCME, CWS, 2000

*Note: Stack concentrations are corrected for 11% oxygen*

The incinerator may be subject to either Municipal or Sewage Sludge standards based upon the total amount of waste type incinerated (>50% as one type) or upon the territorial designation of facility type. According to the CWS “municipal solid waste’ includes any waste that might be disposed of in a non-secure landfill site if not incinerated (i.e., including non-hazardous solid wastes regardless of origin), but does not include “clean” wood waste.

Compliance to these performance limits will be confirmed by stack testing performed by an external contractor every year. Should the performance limits above be exceeded then an investigation will be undertaken to determine the cause of the exceedance. In most cases exceedances will be related to improper waste being fed into the incinerator.

**4.2 Incinerator Ash**

Provided the materials that go into the incinerator are controlled to exclude all hazardous materials, the incinerator ash should be non-hazardous. Even small quantities of hazardous waste, such as batteries, should not be mixed with waste to be incinerated. An ash testing protocol developed by the Government of Nunavut (GN) will be implemented to ensure that the incinerator ash is suitable for disposal in the landfill. Ash not meeting the guidelines will be packaged in drums to be sent to a

certified waste management facility for appropriate treatment, recycling, and/or disposal, or will be buried within the Meadowbank Tailings Storage Facility (TSF). Table 4-2 summarizes the guidelines for metals parameters based on leachate test results.

**Table 4-2: Guidelines for Solid Waste/Process Residuals Suitable for Landfill**

Parameter	Concentration maximum (mg/L)
Arsenic	2.5
Barium	100
Cadmium	0.5
Chromium	5
Lead	5
Mercury	0.1
Selenium	1
Silver	5
Zinc	500

*Note: Standards based on leachate test results*

### 4.3 Composter

There are no Nunavut, federal or other territorial performance limits related to the use of a composter or to quality of compost if disposed of in a landfill. However, internal key performance indicators such as temperature and humidity will be followed as per the Composter Operating and Maintenance Manual (Appendix II).

#### 4.4 Used Oil and Waste Fuel

Agnico Eagle will manage used oil and waste fuel according to the *Used Oil and Waste Fuel Management Regulations* (NWT, 2005) as presented in Table 4-3.

**Table 4-3 Summary of Used Oil and Waste Fuel Regulations**

Activity	Summary of Regulations
Registration	<ul style="list-style-type: none"> <li>• Used oil burner shall be registered with the Chief Environmental Protection Officer.</li> </ul>
Disposal	<ul style="list-style-type: none"> <li>• Used oil/waste fuel will not be disposed of directly into the environment.</li> </ul>
Storage	<ul style="list-style-type: none"> <li>• Used oil/waste fuel will be stored in specifically designed container for hydrocarbons to minimize the risk of spills;</li> <li>• Used oil/waste fuel containers will be periodically inspected for leaks or potential leaks; and</li> <li>• Used oil/waste fuel will be stored as per the Hazardous Materials Management Plan.</li> </ul>
Sampling and Analysis	<ul style="list-style-type: none"> <li>• A sample of one month's feedstock of used oil/waste fuel is required to be tested at least once a year;</li> <li>• Used oil/waste fuel will be tested for:               <ul style="list-style-type: none"> <li>• Flash point; and</li> <li>• Existence and amount of each impurity Listed in Table 4-4.</li> </ul> </li> </ul>
Burning	<ul style="list-style-type: none"> <li>• Used oil/waste fuel will not be openly burned;</li> <li>• Used oil will not be burned in accommodation areas;</li> <li>• Used oil with a flash point of less than 37.7°C will not be burned or blended with another used oil/waste fuel;</li> <li>• Used oil that exceeds guidelines will not be burned.</li> </ul>
Records	<ul style="list-style-type: none"> <li>• The following will be recorded in association with the incineration of used oil/waste fuel:               <ul style="list-style-type: none"> <li>• Volume of used oil/waste fuel incinerated/consumed;</li> <li>• Name and address of person in charge, management or control of the used oil;</li> <li>• Location of production of used oil/waste fuel;</li> <li>• A summary of maintenance performed on used oil/waste fuel burners or processing equipment; and</li> <li>• Volume and nature of the products produced from the used oil.</li> </ul> </li> </ul>

Table 4-4 summarizes the maximum level of contaminants in used oil that can be incinerated as stipulated in the *Used Oil and Waste Fuel Management Regulations* (NWT,2005). Under the regulations blending of used oil that exceeds one of more of the criteria listed in Table 4-4 is not allowed.

**Table 4-4      Used Oil Impurity Limit**

<b>Impurity</b>	<b>Maximum Level Allowed in Used Oil (ppm)</b>
Cadmium	2
Chromium	10
Lead	100
Total Organic Halogens (as Chlorine)	1,000
Polychlorinated Biphenyls	2

## SECTION 5 • INCINERATOR AND COMPOSTER SPECIFICATIONS AND OPERATIONS

---

### 5.1 Incinerator

#### 5.1.1 Specifications

The Mine will select a dual chamber, high-temperature incinerator as the primary incinerator. The technical specifications of one possible brand to be installed are included in Appendix I. The incinerator will be housed inside a separate building that will have sufficient floor space to manage all Mine wastes in one convenient location.

Typical modern, controlled-air, batch, dual chamber incinerators are design using the principles of pyrolysis (starved-air burning condition) in the primary chamber and complete oxidation (high temperature, excess oxygen, and sufficient combustion time) in the secondary chamber. The incineration system will be a two-stage process. In the first stage, waste will be converted to gas in the primary chamber at approximately 650 to 850 degrees Celsius (°C). This process will be self-fueling until the volume is reduced by 90 %. Gasses from the primary chamber will enter the secondary chamber of oxygen-rich and turbulent conditions, which is typically at a higher temperature – around 1,000°C. Combustion will be completed after a retention time of about two seconds. The temperature of combustion gases exiting the stack is anticipated to exceed 700°C and to flash cool in the ambient air, thereby leaving little opportunity for the *de novo* synthesis of dioxins/furans. Heat capture will not be used on the exhaust gases.

Critical process parameters, such as temperature, air flow, and burner output will be computer-controlled to maintain optimal combustion conditions.

For an incinerator capacity suitable for the predicted volumes of waste to be generated at the Mine, the total particulate matter generated is expected to be extremely low. Therefore, dust collection technologies, such as baghouse filters, will not be necessary, as a very minor amount of fly ash will be generated. Ash residues generated in the primary chamber will be manually removed daily using a shovel emptied into a metal bin.

#### 5.1.2 Operation Procedures

General operating procedures for the incinerator will include:

1. Sort the waste on the basis of origin and heating value.
2. Mix the waste to ensure a calorific value within the incinerator's specification and to achieve good combustion inside the primary chamber.
3. The operator will observe the start of the burn cycle to ensure the incinerator is operating correctly.

4. The door to the incinerator will only be opened after the burn cycle is complete and the unit cooled.
5. The ash will be removed from the incinerator before it is charged with the next load of waste to be incinerated.
6. The ash will be placed in drums or bags before disposal.
7. The ash will be disposed of in the on-site landfill. If the concentration of trace metals exceeds the GN's Environmental Guideline for Industrial Waste Discharges (GN 2012), ash will be either packaged and sent to an approved disposal facility or buried in the Meadowbank TSF.

The system will have a sizable front door for easy access to manually load/feed waste into the unit with a front-end loader.

A full set of operating procedures specifying how to operate the incinerator will be developed in consultation with the supplier/manufacturer prior to its use, and its operation will be conducted in accordance with the ECCC Technical Document for Batch Waste Incineration (ECCC, 2010).

### **5.1.3 Emissions**

The incinerator to be purchased for the Mine will be designed to meet performance limits described in Section 4.1. Good engineering practices will be used to ensure required incineration temperatures and dispersion of gases meet applicable air quality standards/guidelines.

The incinerator stack design will incorporate appropriate sampling ports, with caps where necessary, at appropriate locations to allow for stack testing to be undertaken during incinerator operation.

### **5.1.4 Dust/Odour Control Measures**

Modern incinerators are commonly designed such that the non-turbulent atmosphere in the primary burn chamber reduces the formation of particulate matter. Therefore, the need for additional dust and/or odour control measures is not anticipated. Organic/putrescible wastes will be given incineration priority to limit odours.

### **5.1.5 Staffing and Equipment**

The computerized incinerator will typically require one operator to interact with the equipment for approximately 1 to 1.5 hour per day, largely for ash removal, loading, and start-up. Operators are not typically required to be in attendance during the rest of the operation, as it is normally a fully automated process. The incinerator will be designed, installed, and operated so that the operators are not exposed to high temperatures during loading or ash removal due to complete cool down after the burn cycle. Also, the waste will not be allowed to combust until the chamber is sealed thus isolating the worker from smoke and high temperatures.

### **5.1.6 Operator Training**

Operator training will be provided by an experienced technician from the incinerator supplier/manufacturer or from an associated company. Special emphasis will be given to system safety including identification of hazards that the operator should recognize.

### **5.1.7 Inspections**

Weekly inspections will be undertaken of the incinerator building for cleanliness and the proper management of waste delivered to the facility. The Environment Department will carry out the inspections.

## **5.2 Composter**

### **5.2.1 Specifications**

The Brome 624 series in-vessel composter consists of an insulated cylinder that rotates according to pre-set timed intervals. The rotation of the cylinder allows the material inside of the chamber to mix while providing aeration. Aeration is important to provide oxygen for the microorganisms that are digesting organic material to make compost. Heat will be produced during the composting process from the breakdown of organic material by the microorganisms.

The composter requires a certain ratio of carbon-rich materials, or “browns,” and nitrogen-rich materials, or “greens.” Examples of brown carbon-containing materials are dried leaves, paper, and cardboard. Nitrogen-containing materials are fresh or green, such as grass clippings and kitchen scraps. Food scraps provide nitrogen to the system whereas paper and cardboard provide high carbon values. A specific strategy is used to achieve the required balance of nitrogen-rich and carbon-rich materials fed into the composting system such that optimum conditions are provided for the bacteria in the composter. The carbon to nitrogen ratio required will be confirmed by the supplier for the specific model of composter selected by Agnico Eagle prior to commissioning.

The composter will operate in a continuous-feed manner. As more material is added and the cylinder rotates, the digesting material is moved along the vessel and is then discharged at the cylinder’s extremity through an opening that also serves as an air inlet for oxygen. The compostable material will spend a minimum of three days in the composter.

The Brome Composter operating manual is included in Appendix II. The unit to be installed is the Brome 624.

Precautions must be followed for the indoor installation of this composting equipment as per the composter operating manual.

Agnico Eagle will use experience with composting acquired from use of a similar unit currently in operation at the Meadowbank Mine site.

### 5.2.2 Operation Procedures

General operating procedures for the composter include:

1. Collected compostable waste is stored in dedicated waste containers.
2. Waste collected in containers is inspected visually by the composter operator on sorting tables located at the composting facility to ensure it does not contain inappropriate types of waste materials. Materials that do not meet the criteria for composting will be incinerated, recycled, or disposed of as hazardous material.
3. The waste goes through an agricultural mixer used to break down and mix the material. The breakdown of materials increases the surface area to volume ratio and allows for increased aeration and biological activity within the composter.
4. Material is transferred to the composter where the composting process begins.
5. During the composting process, the operator reviews the temperature and humidity of the compost within the composting chamber to ensure targets are reached. The operator visually inspects the compost for foreign matter and to check that the texture and consistency of the compost appears normal.
6. As the compost is discharged, it runs across a screen/sifter that removes any large material that may have been accidentally introduced into the composter. The residual materials will be sorted into incinerator waste, recyclable material, landfill material, or hazardous goods that will be shipped off site. Larger organic material may be reintroduced into the mixer to begin the composting process again.
7. The solid decomposed material is discharged and stored in a bin.
8. The full bin of compost is transported to the landfill for disposal or revalorized for other projects.

If the composting process does not break down the material effectively after the second cycle, or if the composter is temporarily out of service for any reason, the material will then be sent to the incinerator.

### 5.2.3 Odour Control Measures

Since the composter is located in an enclosed area, a ventilation shaft that exits the building is used for the elimination of composting gas and odours. Odours generated during the operation will be mitigated by sweeping the floor, cleaning up any organic matter debris on or around the composter, and removing any material that has fallen on the floor. Waste will also be cleaned up in the loading and unloading areas. Loads of organic matter arriving at the composting building will be promptly mixed and added to the composter.

Careful monitoring of the composting process using appropriate carbon to nitrogen ratios as discussed with the supplier as well as using regular logbook entries and adherence to the procedures and recipes will aid in avoiding the generation of odours. The monitoring of humidity is an important factor in

controlling odours from the composting process. Composting often proceeds well at a moisture content of 40-60% by weight. At lower moisture levels, microbial activity is limited. At higher levels, the process is likely to become anaerobic and foul-smelling.

The Environment Department will monitor the landfill where possible to ensure that wildlife does not become attracted to the compost material being added to the waste.

#### **5.2.4 Introduction of Invasive Species**

Composting will be monitored and controlled. Aerobic conditions will be maintained and includes a high-temperature phase for a specified amount of time that reduces pathogens and weed seeds. Adherence to the composting instructions will avoid concerns over introduction of invasive species to the landfill.

#### **5.2.5 Operator Training**

Personnel operating or performing maintenance on the composter will be trained by a Brome Composter representative. The training will include a composting theory portion and a practical, hands-on portion. A more detailed discussion of individual components, features and functions of the composter can be found in the Brome Composter Operating and Maintenance Manual (Appendix II)

#### **5.2.6 Inspections**

Inspection criteria and work instruction checklists will be developed with assistance from the composter supplier to ensure proper operation of the equipment. Routine inspections of the composter and associated facilities will be conducted by a competent, trained operator prior to every use.

### **5.3 Used Oil and Waste Fuel**

The incinerator will be able to efficiently burn used oil and waste fuel. The quantity of waste fuel is expected to be minor and will be dependent on the adherence to standard operating procedures. The goal is to avoid practices that could result in waste fuel. The principal sources of the used oil will be from oil changes on the mining equipment and light vehicles, as well as oil changes to mechanical gearboxes within the mill. Typical used oil and waste fuel furnaces include a storage tank and a filter to recover sludge prior to burning. Sludge collected in the filters will be drummed and shipped, as needed, to a certified waste management facility for treatment, recycling, and/or disposal.

### **5.4 Closure Plan**

In accordance with the Whale Tail Closure and Reclamation Plan, salvageable buildings and surface structures, including the incinerator and composter building, will be dismantled and demobilized from the site.

## **SECTION 6 • WASTE MANAGEMENT**

---

Figure 6-1 provides a schematic diagram for the management of solid waste and used oil produced on site.

### **6.1 Approach**

The amount of waste will be reduced through composting, purchasing policies that focus on reduced packaging, and on-site diversion and segregation programs.

### **6.2 Acceptable Waste for Incineration**

Acceptable wastes for incineration, in the primary incinerator as per the operational instructions, include the following:

- Wood;
- Food containers and wrappings including plastics that are contaminated by food;
- Food waste (divert to composter);
- Paper and cardboard (divert to composter); and
- Dead animals - small size only (divert to composter);

### **6.3 Acceptable Waste for Composting**

- Organic matter including food (e.g., coffee grounds and tea bags, eggs and eggshells, fruit and vegetable peelings, meat, chicken and fish including bones, nut shells, pasta, rice, sauces and gravy, solid dairy products, table scraps and plate scraping etc. as well as leaf and yard organic material including brush and tree trimmings);
- Paper and cardboard; and,
- Dead animals (small size only).

### **6.4 Unacceptable Waste for Incineration**

Materials that are not listed in Section 6.2 are unacceptable for incineration. These materials include, but are not limited to:

- Uncontaminated plastics, including chlorinated plastics;
- Inert materials such as concrete, bricks, ceramics, ash;
- Bulky materials such as machinery parts or large metal goods such as appliances (shipped south and recycled in an accredited facility);
- Radioactive materials such as smoke detectors;
- Potentially explosive materials such as propane tanks, other pressurized vessels, unused or ineffective explosives;

- Other hazardous materials such as organic chemicals (Polychlorinated biphenyls, pesticides), other toxics (arsenic, cyanide);
- Electronics (shipped south and recycled in an accredited facility);
- Batteries (shipped south and recycled in an accredited facility);
- Asbestos;
- Dry wall;
- Vehicles and machinery (shipped south and recycled in an accredited facility);
- Fluorescent light bulbs;
- Whole tires;
- Any materials containing mercury;
- used oil or waste fuel that exceeds the maximum impurity limits for parameters listed in Table 4-4;
- used oil and waste fuel with a flash point of less than 37.7°C; and
- propane.

## 6.5 Unacceptable waste for composting

Materials that are not listed in Section 6.3 are unacceptable for composting. These materials include, but are not limited to:

- Food containers and wrappings including plastics that are contaminated by food;
- Used oil that exceeds the Maximum Impurity Limits for parameters listed in Table 4-4;
- Used oil with a flash point of less than 37.7 deg C;
- Paint;
- Solvents;
- Materials included in Section 6.4.

## 6.6 Waste Volumes

### 6.6.1 Solid Waste, Incinerator Ash, and Compost

The number of people working on-site and the activities occurring at the time have a direct bearing on the volume of waste destined for the landfill, the incinerator, the composter, and the amount removed from waste streams for reuse and recycling.

The quantity of waste to be incinerated and composted is estimated at 1,300 kilograms per day during operations with a camp size of 400 persons.

The incineration process results in a 63% reduction in mass. Incinerator ash will be disposed of in the on-site approved landfill.

Weekly organic matter quantities have been estimated from the quantities from the Meadowbank composter and may be subject to change:

- Estimated 2,000 kg: food materials (e.g., coffee grounds and tea bags, eggs and eggshells, fruit and vegetable peelings, meat, solid dairy products, table scraps and plate scraping etc. as well as leaf and yard organic material including brush and tree trimmings);
- Estimated 500-900 kg: cardboard quantity; and
- ~400 kg per day of compost coming out and will be put in the landfill.

### **6.6.2 Used Oil and Waste Fuel**

The quantity of used oil anticipated to be generated from the servicing of machinery at the Mine was estimated to be approximately 365,000 litres per year (based on incineration's maximum capacity of 1,000 litres per day).

The quantity of waste fuel is expected to be small but may vary between years.

### **6.7 Waste Incineration Rate**

Due to the predicted volumes of waste to be generated at the site, the incinerator will have an approximate incineration capacity of 1,500 kilograms per day. If this cannot be achieved due to a lower volume of waste, the primary chamber could be used as storage of wastes until the desired volume is reached. The batch cycle will be 6 to 10 hours for the burn cycle, followed by a cool-down of 6 to 8 hours.

Figure 6-1: Process Flow Chart for Waste Incineration and Compost

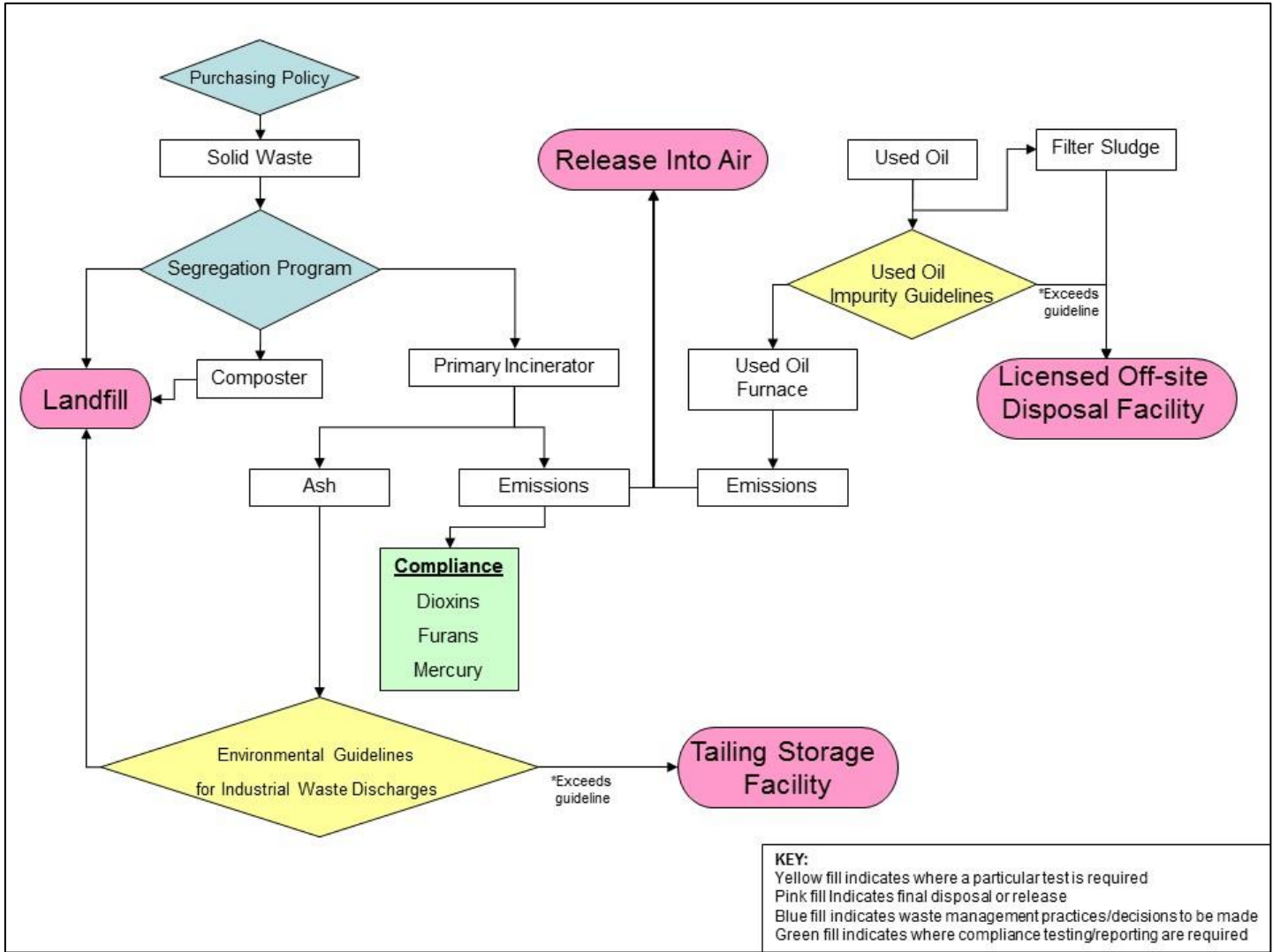

## SECTION 7 • MONITORING AND TESTING

---

The following presents the monitoring and testing plan for the incinerator and composter.

### 7.1 Incinerator Emissions and Testing

The incinerator stack will incorporate appropriate sampling ports at appropriate locations, in right angle configuration, to allow for stack testing to be undertaken during incinerator operation. Table 7-1 summarizes the frequency of testing that will be completed.

**Table 7-1: Summary of Incinerator Emissions Testing**

	Frequency	Number of Test Required	Reference
Dioxins and Furans	Annual	3	CCME 2001a
Mercury	Annual	3	CCME 2000

### 7.2 Incinerator Ash

Upon commissioning of the new incinerator at the Mine, an ash testing protocol will be implemented to ensure that the incinerator ash is suitable for disposal in the landfill.

Three ash samples will be collected (one per month for the first 3 months of the incinerator in operation) and the leachate tested for metals content. The samples will be compared to the *Environmental Guideline for Industrial Waste Discharges into Municipal Solid Waste and Sewage Treatment Facilities* (GN, 2011a) presented in Table 4-2. Following the initial testing, ash samples will be collected and tested annually, or upon a significant change in the source or type of material sent to the incinerator.

If monitoring indicates the ash is above the guidelines and not suitable for landfilling, an investigation will be undertaken to identify the cause and eliminate the source for the exceedance. If deemed necessary, the ash will be packaged in drums and sent to the tailings storage facility (TSF) or a certified waste management facility for treatment, recycling, and/or disposal.

### 7.3 Compost

The compost output will be visually inspected each time it exits the sieve. Should Agnico Eagle decide to explore other options for potential uses of compost, further analytical testing will be undertaken as detailed in relevant compost quality guidelines.

### 7.4 Used Oil/Waste Fuel Testing

A sample of feedstock of used oil/waste fuel will be collected each month with one of the monthly samples being tested each year. Used oil/waste fuel not meeting impurity limits or having a flash point

less than 37.7°C will be drummed and shipped to a certified management facility for re-refining, treatment, recycling, and/or disposal.

## SECTION 8 • REPORTING

---

The quantity and type of materials incinerated and composted on-site during operations, together with results from periodic stack emissions, used oil and ash monitoring, will be included in the annual report.

### 8.1 National Pollutant Release Inventory

The National Pollutant Release Inventory is a Canadian database containing information on the annual on-site release of specific substances to the air, water, and land from industrial and institutional sources (ECCC, 2020). The National Pollutant Release Inventory provides a list of tracked substances and requirements for reporting incinerator emissions. Table 8-1 lists the substances under the National Pollutant Release Inventory that the Mine expects to report annually. In addition, there are certain substances, as indicated in Table 8-1 that may require reporting depending on the quantity of incinerator emissions. Whether or not reporting is necessary will depend on results of periodic stack emission testing data and the quantity of annual emission calculated with emissions factors.

**Table 8-1 National Pollutant Release Inventory Incineration Reportable Substance List**

Substance	Note
Hexachlorobenzene	Required to report
Dioxins and Furans	
Carbon Monoxide	Required to report if released to air from facility in a quantity of 20 tonnes or more per annum
Oxides of Nitrogen	
Sulphur Dioxide	
Total Particulate Matter with diameter <100 microns	
Particulate matter with diameter less than or equal to 10 microns (PM <sub>10</sub> )	Required to report if released to air from facility in a quantity of 0.5 tonne or more per annum
Particulate matter with diameter less than or equal to 2.5 microns (PM <sub>2.5</sub> )	Required to report if released to air from facility in a quantity of 0.3 tonne or more per annum

### 8.2 Greenhouse Gas Emissions and Global Warming

Agnico Eagle is committed to reporting greenhouse gas emissions to ECCC in support of Canada's Greenhouse Gas Reporting Program and to NIRB in its annual report as per the approved Greenhouse Gas Reduction Plan (Agnico Eagle, 2018).

## **SECTION 9 • PLAN REVIEW AND ADAPTIVE MANAGEMENT**

---

This ICWMP will be maintained by Agnico Eagle to reflect the current operations at the Whale Tail Mine, permit requirements and regulatory setting. The plan will be reviewed on a regular basis and revised when necessary to ensure that the Mine staff, operators, and regulatory bodies are kept aware of any changes to operational procedures.

Should Agnico Eagle determine the need to add additional composters to the on-site operation, the ICWMP will be reviewed and updated to reflect this change to the operation. Should Agnico Eagle wish to employ compost for other potential uses, this management plan will be updated to incorporate the above-mentioned guidelines.

The latest ICWMP will be made available at all times by Agnico Eagle for review by the NIRB, NWB, GN, and ECCC.

## REFERENCES

---

- Agnico Eagle (Agnico Eagle Mines Limited). 2018. Greenhouse Gas Reduction Plan. Submitted to the Nunavut Impact Review Board. September 2018.
- CCME (Canadian Council of Ministers of the Environment). 1998. Policy Statement for the Management of Toxic Substances. Available on-line: [http://www.ccme.ca/assets/pdf/toxics\\_policy\\_e.pdf](http://www.ccme.ca/assets/pdf/toxics_policy_e.pdf)
- CCME 2000. Canada-Wide Standards for Mercury.
- CCME 2001a. Canada-Wide Standards for Dioxins and Furans.
- ECCC (Environment and Climate Change Canada). 2004. Toxic Substances Management Policy (TSMP).
- ECCC 2010. Technical Document for Batch Waste Incineration.
- ECCC 2017. Solid Waste Management for Northern and Remote Communities: Planning and Technical Guidance Document.
- ECCC 2020. Guide for Reporting to the National Pollutant Release Inventory 2020 and 2021.
- GN (Government of Nunavut). 2010. Environmental Guideline for Mercury-Containing Products and Waste Mercury. Government of Nunavut, Department of Environment, Environmental Protection Service.
- GN 2011a. Environmental Guideline for Industrial Waste Discharges into Municipal Solid Waste and Sewage Treatment Facilities.
- GN 2012. Environmental Guideline for the Burning and Incineration of Solid Waste. Government of Nunavut, Department of Environment, Environmental Protection Service
- GN 2023a. Environmental Guideline for Ambient Air Quality.
- GN 2023b. Environmental Guideline for General Management of Special and Hazardous Waste.
- MOJ (Minister of Justice) 1999. CEPA (Canadian Environment Protection Act). Available on-line: <http://laws-lois.justice.gc.ca/PDF/C-15.31.pdf>
- MOJ (Minister of Justice) 2021. Cross-border Movement of Hazardous Waste and Hazardous Recyclable Material Regulations. Available on-line: <https://laws-lois.justice.gc.ca/PDF/SOR-2021-25.pdf>
- NWT 2005. Used Oil and Waste Fuel Management Regulations, Department of Environment, Government of Nunavut.

## **APPENDIX I**

### **Technical specifications of the Proposed Incinerator**

# Eco Waste Solutions (EWS) Quotation

**Technical Overview, Technical Specifications  
& Itemized Budgetary Quotation  
For Batch Incineration Equipment**

**Prepared for:  
BBA**

**Agnico Eagle's  
Meliadine Feasibility Project**

**Submitted by:  
Eco Waste Solutions ("EWS")**

Quotation No: AEM-ECO 1.5 TN1P 100L

BBA RFQ 5287063-PM0014/6509

Quotation Date: August 25, 2014

**Eco Burn Inc.**

5195 Harvester Road, Unit 14

Burlington, ON, Canada L7L 6E9

Tel: 905-634-7022 Fax: 905-634-0831

Toll Free: 1-866-326-2876

**Ms. Tracey Goldberg**

[tgoldberg@ecosolutions.com](mailto:tgoldberg@ecosolutions.com)

Ext.231



***Eco Waste Solutions is a manufacturer of innovative point-of-need waste systems. Our mission is to provide robust, reliable, thoughtfully-designed equipment that is environmentally responsible. We foster a climate of energy and engagement within our team and with our clients; and we rely on procedures and practices that evolve with input from our clients and participation of employees in a continuous improvement effort.***

***Eco Waste Solutions' goal is to be a world leader in sustainable waste management solutions for our planet.***

## INCINERATION AND WASTE MANAGEMENT

---

**Eco Waste Solutions (EWS)** is a Canadian environmental technology company focused on point-of-need waste management solutions. **EWS** incineration systems offer a sustainable waste management alternative for projects in remote locations and regions that are ecologically sensitive, where proponents want to avoid the environmental legacy of a landfill or other traditional disposal methods used in the past.

### ***Why is incineration often the best solution for point-of-need waste management?***

- Landfilling of waste, without prior treatment, is no longer an acceptable practice for domestic waste management. Many countries have banned the practice of landfilling without recovering to the maximum extent possible and treating the residual while recovering valuable energy.
- The construction of a landfill is the creation of a permanent feature that requires on-going monitoring and management.
- With land disposal there is always a risk of material and/or microbes migrating from the landfill via wind, animal or bird movement, or water run-off causing contamination far from the site of disposal.
- Shipping material to other communities or sites for disposal is now viewed as pushing the problem onto someone else to deal with.
- Transportation is also heavily dependent upon fossil fuels, impacts the air and contributes to greenhouse gases – shipping waste long distances has a high environmental cost.
- The potential for contamination and liability is greatly increased once waste leaves the generator's site. Shipping material away from the creation point can be risky, if the material is mishandled or there is an accident the waste can pose an uncontrolled threat to the population and/or the environment

### ***How does incineration offer a better solution?***

- Processing waste at the point-of-need reduces transportation impacts and lowers the risk of contamination to waterways and/or the land.
- The ash residual, even with the presence of metal and glass containers, will represent less than 10% of the original volume of waste. The process includes a long and thorough burn down of the material to an ash residual that has minimal unburned carbon, is non-leaching and essentially inert.
- Waste materials are exposed to the required temperatures for destruction of disease causing pathogens, an important consideration in communities because of the risk of home care medical waste which often ends up in the landfill. Pathogen destruction makes incineration a suitable means for disposing of dewatered sewage sludge.
- Modern incineration with good control and high temperatures ensures that there will be no smoke and/or odour – a huge improvement over the uncontrolled burning that often occurs at landfills. Packages can be supplied with integrated air pollution control scrubbers guaranteed to meet the strictest standards in the world.
- Incineration is a fully commercialized and trusted method of waste disposal. Experimental technologies such as gasification will take many years before they are fully commercialized, dependable methods of waste disposal that a community can be relied upon for their long-term waste management needs.

## **ECO WASTE INCINERATION EQUIPMENT: RUGGED AND FIELD-PROVEN**

---

A modern advanced technology incinerator, like the **Eco Waste Solutions** system proposed in this document, can be the basis of a pollution prevention approach to waste management for a remote mining operation.

Having an incinerator at the point-of-need allows for immediate and full control of the disposal of waste. This cost-effective waste management solution turns waste into non-toxic, non-leaching ash residual that will represent less than 10% of the original volume of waste prior to incineration.

The **Eco Waste Solutions (EWS)** standard equipment packages are well known to be high quality and extremely robust. In 1995, **EWS** began supplying equipment to the Canadian Department of Defence (DND). The first contract with the DND was at Canada Forces Station Alert, the northern-most inhabited place in the world. The equipment deployed to Alert in 1995 is still serving this remote military post today.

The expectation of military ruggedness was influential in the early **EWS** equipment designs and remains the construction standard used by **EWS** today. **EWS** products are noticeably more robust than traditional incinerators. Materials of construction most notably the steel shell, refractory lining, electrical and controls are more advanced and higher grade than is traditionally available. These factors are strongly correlated with equipment durability and lifespan; factors that have led to the strong following **EWS** has earned among its very demanding clients in the mining and military industries. Considerable R&D investment and continuous product improvement have led to a thoughtful design that is more practical and reliable in the field.

**EWS** also uses the latest in control technology including PLC (Programmable Logic Controller) computer-based system automation and the latest communication protocols.

Finally, one of **EWS'** most distinguishing features is the higher standard of environmental integrity inherent in its products. **EWS** has proven its environmental performance through more independent third-party testing and verification than any other incinerator manufacturer.

### ***How is Eco Waste Solutions Technology different?***

- Our industry-leading equipment with computerized automation and comprehensive monitoring has become the benchmark for many new regulatory requirements
- The automated operation of the system minimizes the need for a highly technical operator and constant operator input
- Customer feedback has been the basis for many of the advancements that our technology has over traditional equipment. The product has developed with a focus on ease of use, safety and reduced labor.
- **EWS** has a patented incineration process with unique process control that minimizes harmful emissions particularly Dioxins and Furans

## DESIGN SPECIFICATION CRITERIA

---

### Reference

**Eco Waste Solutions (EWS)** technical and commercial proposal, presented in this document, is based on information provided by, and in response to a Request for Quotation (RFQ) issued by **BBA** on behalf of **Agnico-Eagle Meliadine Division** dated August 18, 2014.

### The Project

The **Meliadine Mining** property is located near the western shore of Hudson Bay in the Kivalliq region of Nunavut. It is about 25 km northwest of Rankin Inlet and 290 km southeast of Agnico-Eagle's Meadowbank Mine.

### Waste Description

As per the RFQ, specifically in the datasheet provided, the waste materials to be processed in the incinerator are described as follows:

Acceptable Solid Waste for Incineration	
	Organic matter (including food)
	Food containers and wrappings (including plastic that is not contaminated by food)
	Paper
	Wood
	Sewage sludge --- max: 200 kg/day
	Waste oils (shall be used as fuel) --- approx. 1000 l/day

### Waste Quantity

The "capacity" criteria in the datasheet provided, stipulates that the incinerator be designed to process up to **1500 kilograms** of waste materials per day, which includes **200 kilograms** of sewage sludge. Additionally, the design criteria states that the incinerator be able to process up to **1000 litres** of waste oil per day.

### EWS Waste Assumptions

One of the most critical waste characteristics to consider when designing the most appropriate incinerator package is the waste density of the material to be processed. With almost any disposal method, waste density has a serious impact on the sizing of the incineration system.

## DESIGN SPECIFICATION CRITERIA (CONT..)

---

Based on the description of the waste material, provided in datasheet, EWS has made the following assumptions on the waste characteristics:

**Table 3: EWS Assumptions on Waste Characteristics**

Description	Total Moisture Content	Average Waste Density Range	Average Heat Value
Mixed Solid Camp Waste Material	Up to 45%	10-15 lbs/ft <sup>3</sup> 160-240 kg/m <sup>3</sup>	5000 BTU/lb 11655 KJ/kg

Also, EWS has made these additional assumptions and clarifications:

- The sewage sludge available for processing must be de-watered (25-30% solid content) prior to incineration
- The de-watered sewage sludge will be added onto a layer of other wastes and will comprise no more than 20% of the batch by weight
- The solid waste and de-watered sludge will need to be co-mingled to ensure that any wet low heat value waste is mixed with the other drier higher value materials.
- Regardless of recycling programs that may or may not be available, it is assumed that the waste materials described is typical of domestic solid waste and will include some plastic packaging and containers. The waste is expected to be bagged or stored in skips/bins around the mine operation then brought to the incinerator by truck.
- It is important to note that inappropriate materials including, but not limited to, reactive/explosive chemicals and items containing heavy metals will not be processed in the incinerator proposed herein.
- If waste audit data is available, it would be beneficial for EWS to review the details of the waste streams at site, to confirm all waste material is deemed acceptable for processing in the incinerator packages proposed herein. For now, this proposal and EWS recommendations are based on EWS assumptions from past experiences at other mine sites.
- Please see Document: **EWS Acceptable and Unacceptable Waste Streams**, for more information on what waste materials are deemed appropriate for incineration

## **DESIGN SPECIFICATION CRITERIA (CONT..)**

---

### **Addressing Waste Oil**

To address the need of disposing the waste oils generated at site, EWS recommends the purchase of the **High Output Waste Oil Burner (HWOB) & Piping Package**, which is integrated as part of the incinerator package.

This HWOB can utilize the waste oils available on site and function as a fuel source to operate the incinerator system, in lieu of diesel. This packaged burner will not only dispose of the waste oils in an environmentally sound manner, but it will also decrease the daily operating costs of the waste incinerator system.

Both the Primary and Secondary Chamber will be equipped with a diesel-fired burner. The burner on the Primary Chamber is only used for heating up the chamber and igniting the waste. Once the waste is ignited, the diesel-fired burner turns off and the burning process is self-fueling. Most of the fuel usage is in the Secondary Chamber, therefore only the Secondary Chamber is equipped with a HWOB.

## EWS PRODUCT SELECTION

---

### ECO Model Batch Incineration Equipment

EWS offers a range of products to accommodate point-of-need waste disposal. These incinerator systems can be combined with other components, as required or mandated by local environmental regulations, such as weigh scales, building enclosures, air pollution control systems (scrubbers), continuous emissions monitoring systems, heat recovery features, etc.

Based on the given waste description, waste quantity and waste assumptions; EWS proposes the ECO Model, specifically the **ECO 1.5 TN 1P 100L** system to treat the solid and waste oils generated at this site.

The **ECO 1.5TN1P 100L** package is designed to process up to 1500 kilograms of solid waste which also includes 200 kilograms of de-watered sewage waste and is equipped with a **High Output Waste Oil Burner & Piping Package** for processing up to 1000 litres/day of used waste oils, as described previously.

#### ECO 1.5TN1P 100 L Incinerator Package

	<b>ECO 1.5TN1P 100L</b>
<b>Maximum Incinerator Processing Rate of Solid Waste</b>	Up to 1500 kg/day
<b>Maximum Incinerator Processing Rate of Waste Oil</b>	Up to 1000 litres/day (100 LPH) (during the burn cycle only)
<b>Hours of operation</b>	Burn Cycle: 6-10 hours Cool Down Cycle: 6-8 hours

## ECO WASTE SOLUTIONS BATCH INCINERATION TECHNOLOGY

### Main System Components

1. Primary Chamber
2. Secondary Chamber
3. Main Control Panel



COMPONENT	FUNCTIONAL OVERVIEW
<b>Primary Chamber</b>	<p>In the first stage, a diesel fired burner is used to elevate the temperature of the <b>Primary Chamber</b> to ignite the waste. Once the Chamber reaches a temperature of approximately 650-850 °C, the burn process becomes self-fuelling and the burner will shut off. To save fuel and control temperatures, only when the energy contained within the waste is depleted, will the burner periodically turn on. At these operating temperatures, waste is allowed to fully combust and is rendered sterile. Waste is reduced in volume by over 90%. Independent tests have shown that the residual ash is non-hazardous, non-leaching and essentially inert. After enduring the combustion process, metals and glass remain intact. Preservation of metals and glass not only protects the refractory lining from damage caused by melted and fused metals and glass, but also allows for post-combustion recycling where possible.</p>
<b>Secondary Chamber</b>	<p>As waste burns in the Primary Chamber, gases containing the products of combustion enter the high temperature zone of the <b>Secondary Chamber</b> for cleansing. The <b>Secondary Chamber</b> is sized to retain the incoming gases for a minimum of 2 seconds at 1000°C. This chamber utilizes a packaged, high output, fully modulating diesel burner to maintain the required temperature (even in the absence of energy input from the first stage which is important when processing wet or low energy waste such as food). This stage employs a large blower, tightly controlled by the control system using a variable frequency drive on the motor. The blower creates the turbulence required to mix the gases and oxygenate them. This fosters the high efficiency combustion required to break hydrocarbon chains into carbon dioxide and water vapour.</p>
<b>Main Control Panel</b>	<p>There is one <b>Main Control Panel</b> for the incinerator package that controls all of the interconnecting modules. The Operator has one simple interface to start the equipment, view system status and change control settings if required. The system utilizes a PLC (programmable logic controller) to automate its functions. Incinerator critical process parameters such as temperature, combustion airflow, burner output are operated using EWS' patented system control program to maintain optimal combustion.</p>

## EWS BATCH SYSTEM OPERATING PHILOSOPHY

---

It is recommended that a heated and insulated building enclosure (provided by others) be installed on site to house the incinerator system proposed herein.

Generally speaking there is no need for pre-sorting of the waste if source separation is practiced to keep inappropriate materials out of the waste feed. The system operates in a batch style. As proposed, the system includes a full size front door for easy access to load the waste manually. It is expected that each day the **Primary Chamber** will be loaded to design capacity or at a minimum, to half capacity. If waste quantities are not sufficient to operate the machine daily, it can be used to store the waste until requirement is met.

The use of a weigh scale to confirm daily throughput and for record keeping is recommended and included in this proposal in the basic package, as it is an **Environment Canada's Technical Document for Batch Incineration (March 2009) compliant accessory**. Other scales (sizes and types) are available and some have been included as optional items for purchase, should the buyer wish to upgrade or downgrade from the weigh scale selected in the basic package.

Once loading is complete, the door is sealed shut and the **Secondary Chamber** is fired. The system is interlocked so that **Primary Chamber** waste is not allowed to combust until the **Secondary Chamber** is at operating temperature. Once this occurs, usually within the first 30 minutes of the cycle, the **Primary Chamber** cycle is initiated. During this phase, gaseous products of combustion produced from the solid waste burning in the **Primary Chamber** are burned off in the highly oxygenated, turbulent environment of the **Secondary Chamber** for a minimum of 2 seconds at a temperature of 1000°C to complete the combustion reaction.

Typically, the Operator only remains present to load waste and supervise the beginning of the process, generally the first hour of the burn, and then is no longer required to be at the incinerator. The system will complete the burn-cycle and cool-down phases automatically. Based on the waste quantity and description, the burn-cycle is expected to occur over 6 to 10 hours, but could be longer depending on waste characteristics, to allow for thorough burn down. The cool-down phase that automatically follows is generally 6 to 8 hours. At completion, the operator will then be able to open the **Primary Chamber** door and clean out the ash. This is generally performed the next day prior to loading the **Primary Chamber** with another day's waste.

As available, waste oils such as waste crankcase, hydraulic and other lubricating oils can be burned in the **Secondary Chamber** of the incinerator system by utilizing the integrated **High Output Waste Oil Burner & Piping Package**. The heat value of the waste oil is significant and can reduce the amount of virgin fuel when they are being processed greatly reducing the system's operating costs and solving another waste problem on-site.

The entire process will be controlled by the PLC in the **Main Control Panel**. All key operating parameters will be controlled to factory pre-set settings using the integrated PLC. For simplicity of operation, the **Main Control Panel** comes with a full colour touch-screen user interface. The Operator can see the status of all of critical components and visual alarms for any malfunctions. The software also allows for logging and recording of system data, including historical trends.

## EWS TECHNICAL SPECIFICATIONS: ECO MODEL INCINERATION SYSTEM

INCINERATOR COMPONENT	DETAILS
<b>General Overview</b>	<ul style="list-style-type: none"> <li>• Custom sized, two-stage, controlled air, batch style incineration system</li> <li>• Shop assembled as packaged unit (including pre-piping and pre-wiring)</li> <li>• Tested before shipment and knocked down for transport purposes</li> <li>• Designed with lifting lugs for installation and maintenance purposes</li> </ul>
<b>Primary Chamber</b>	<ul style="list-style-type: none"> <li>• One (1) chamber to hold entire waste load</li> <li>• Capacity of chamber: up to 1500 kg/day</li> <li>• Batch cycle time: 6-10 hours (burn cycle) and 6-8 hours (cool-down)</li> <li>• Operating temperature of 650 °C to 850 °C</li> </ul> <p>Includes:</p> <ul style="list-style-type: none"> <li>• Manifold with air inlets (ports) for combustion air and blower for cooling</li> <li>• Viewing ports to permit safe observation of the combustion process during the burn cycle</li> <li>• Large front loading door for convenient manual loading of waste and for manual ash removal</li> </ul>
<b>Secondary Chamber</b>	<ul style="list-style-type: none"> <li>• Completely separate vessel from the Primary Chamber to expose gaseous products of combustion to high temperature</li> <li>• Operates at 1000 °C with a retention time of 2 seconds</li> </ul> <p>Includes:</p> <ul style="list-style-type: none"> <li>• Manifold air inlet (ports) for combustion and cooling air with excess air blower</li> <li>• Viewing ports to permit safe observation of the process</li> <li>• Access door for maintenance purposes</li> </ul>
<b>Outer Shell/Casing</b>	<ul style="list-style-type: none"> <li>• 6 mm (1/4" steel) thick carbon steel refractory lined, sand blasted, primed, painted with rust-inhibiting and heat resistant paint</li> <li>• The casing plate temperature will not exceed 200 °F (93 °C) during operation</li> </ul>

INCINERATOR COMPONENT	DETAILS
<b>Refractory Lining</b>	Combination of durable, resilient refractories as follows: <u>Primary Chamber</u> <ul style="list-style-type: none"> <li>• <u>Walls</u> (6" thick ceramic fiber blocks), this refractory is held in place with a minimum Type 310SS (stainless steel) anchors</li> <li>• <u>Floors</u> (6" thick reinforced castable refractory)</li> </ul> <u>Secondary Chamber</u> <ul style="list-style-type: none"> <li>• <u>Walls</u> (6" thick ceramic fiber blocks), this refractory is held in place with a minimum Type 310SS (stainless steel) anchors</li> <li>• 18" firebrick walkway</li> </ul>
<b>Exhaust Stack</b>	<ul style="list-style-type: none"> <li>• Mild steel ¼" welded steel refractory lined stack in flanged sections for ease of on-site erection</li> <li>• Self-supporting and designed for local climatic conditions</li> <li>• Includes spark arrestor</li> </ul>
<b>Diesel Burner Package</b>	<ul style="list-style-type: none"> <li>• UL/CSA approved</li> <li>• <u>General</u>: Forced draft, pressure-mechanical atomizing, with built-in blower to supply combustion air, complete with silencer and damper, oil pump driven by blower motor, complete with integral relief valve and filter, pressure gauge, high voltage ignition transformer.</li> <li>• <u>Control</u>: electronic combustion control relay with scanner to control combustion and to supervise flame. Control to shut off fuel within 5 seconds upon flame failure or upon signal of a safety interlock and to ensure, when restarted, in sequence, ignition and supervision of burner operation. Main burner in the Secondary Chamber is fully modulating.</li> </ul> <p><b>Please see <i>Items by Others</i> in this proposal for other accessories to be considered and included with diesel day tank.</b></p>
<b>Integrated High Output Waste Oil Burner &amp; Piping Package</b>	Packaged supplementary specialty fuel burner (UL/CSA approved) for processing waste oils at a rate of up to 100 litres per hour <u>Includes</u> : <ul style="list-style-type: none"> <li>• waste oil pump with integrated oil pressure gauge, relief valve and filter, blower and burner air/fuel and temperature controller</li> <li>• Interconnecting piping to burner (maximum 15 feet total distance), includes suction line filter and check valve</li> </ul> <p><b>Please see <i>Items by Others</i> in this proposal for other accessories to be considered and included with waste oil day tank.</b></p>

INCINERATOR COMPONENT	DETAILS
<b>Blowers</b>	<ul style="list-style-type: none"> <li>• One (1) in Primary Chamber</li> <li>• One (1) in Secondary Chamber for Oxidation, VFD controlled</li> <li>• One (1) as part of High Output Waste Oil Burner &amp; Piping Package</li> </ul>
<b>Main Control Panel</b>	<p>Main Control Panel with motor starters, overloads and breakers for all components is housed in a NEMA 4 enclosure: Features include:</p> <ul style="list-style-type: none"> <li>• Variable Frequency Drive (VFD) controls the Secondary Combustion Fan</li> <li>• Single point electrical connection</li> <li>• Emergency stop button</li> </ul> <p>Integrated Allen Bradley Programmable Logic Controller (PLC) automatically monitors the process, and controls the following functions:</p> <ul style="list-style-type: none"> <li>• Temperature control, air/fuel modulation, system interlocks</li> <li>• <b>Environment Canada's Technical Document for Batch Incineration (March 2009) compliant monitoring and data acquisition system.</b> Equipment includes temperature sensors (primary, secondary and stack), differential pressure sensors with transmitter, monitoring of burner functions, auxiliary burner operation and fan amperage monitoring via current transducer, door position interlock monitoring, high temperature limit and interlock, low fuel level limit and interlock, air proving switch interlocks and integrated weigh scale to record the weight of waste prior to incineration</li> <li>• PLC designed to allow for remote diagnostics of incinerator with Vendor during trouble shooting operations, if desired</li> </ul>
<b>4G Control System</b>	<p>Touch-Screen Operator Control Panel Display makes system start up and operation visual and intuitive. The display also allows the Operator to view operating parameters (settings and signal outputs) during operation.</p> <ul style="list-style-type: none"> <li>• Pre-installed with EWS' user friendly easy to understand graphics customized to reflect the package's unique configuration and components.</li> <li>• Screens include graphic representation of the equipment with status of all major components, display of alarms or system faults and data trending using historical charts</li> <li>• All system inputs above are recorded and logged for record-keeping purposes</li> <li>• Data acquisition system allows for historical trending of key operating conditions</li> <li>• Logged data can be transferred to storage device using USB port on panel for easy transfer to PC and printing of reports using excel or other windows based programs</li> <li>• The system automatically records operations and data port allows for data transfer of data for easy record-keeping. This feature is also useful in managing data for submission to regulatory bodies</li> </ul>

INCINERATOR COMPONENT	DETAILS	
<p><b>Process Monitoring</b></p> <p><i>Environment Canada's Technical Document for Batch Incineration (March 2009) compliant accessory</i></p>	<p>The continuous process monitoring of the listed parameters are part of EWS standard scope of supply and are at no additional cost and will comply with <b>Environment Canada's Technical Document for Batch Incineration (March 2009)</b> and <b>Nunavut</b> requirements:</p>	
	ELEMENT	DETAIL
	<p><b>Base System Parameters</b></p>	<p>Continuous Process Monitoring Includes:</p> <ul style="list-style-type: none"> <li>• Primary Chamber, Secondary Chamber and Stack Temperature;</li> <li>• System Pressure and Draft</li> </ul>
	<p><b>Analyzer Type</b></p>	<p>Temperature: Thermo Kinetics thermocouple Pressure Transmitter: Dwyer transmitter</p>
	<p><b>Measurement Sensitivity</b></p>	<p>Temperature range: -250°C to 2,750°C Pressure range: -2" WC to 2" WC</p>
<p><b>Data Acquisition System</b></p>	<p>Integrated into the Allen Bradley PLC and logged internally and displayed in historical trending graphs.</p>	

INCINERATOR COMPONENT	DETAILS										
<p><b>Continuous Emissions Monitoring System (CEMS)</b></p> <p>Environmental Guideline for Burning and Incineration of Solid Waste compliant accessory</p>	<p>Nunavut Department of Environment “ <b>Environmental Guideline for Burning and Incineration of Solid Waste</b>” section 4.3 “Commercial Camps” lists the monitoring and control systems required as “key operational parameters must be monitored using on-line instruments capable of continuously measuring the combustion process and stack emissions quality.”</p> <table border="1" data-bbox="532 489 1382 1167"> <tr> <td data-bbox="532 489 800 625"><b>Base System Parameters</b></td> <td data-bbox="800 489 1382 625">Measures Opacity</td> </tr> <tr> <td data-bbox="532 625 800 726"><b>Compliance</b></td> <td data-bbox="800 625 1382 726">EPA PS-1</td> </tr> <tr> <td data-bbox="532 726 800 930"><b>General</b></td> <td data-bbox="800 726 1382 930"> <ul style="list-style-type: none"> <li>• Flanged mounting to stack ports</li> <li>• Transceiver/Reflector</li> <li>• Local control panel (standard specifications available, other specifications may be available)</li> <li>• Air purge assembly</li> </ul> </td> </tr> <tr> <td data-bbox="532 930 800 1062"><b>Calibration</b></td> <td data-bbox="800 930 1382 1062">Calibration kit with 3 standards and carrying case included (on-site calibration or RATA by others)</td> </tr> <tr> <td data-bbox="532 1062 800 1167"><b>Data Acquisition System</b></td> <td data-bbox="800 1062 1382 1167">Signal outputs sent to the incinerator PLC for display on the local HMI.</td> </tr> </table>	<b>Base System Parameters</b>	Measures Opacity	<b>Compliance</b>	EPA PS-1	<b>General</b>	<ul style="list-style-type: none"> <li>• Flanged mounting to stack ports</li> <li>• Transceiver/Reflector</li> <li>• Local control panel (standard specifications available, other specifications may be available)</li> <li>• Air purge assembly</li> </ul>	<b>Calibration</b>	Calibration kit with 3 standards and carrying case included (on-site calibration or RATA by others)	<b>Data Acquisition System</b>	Signal outputs sent to the incinerator PLC for display on the local HMI.
<b>Base System Parameters</b>	Measures Opacity										
<b>Compliance</b>	EPA PS-1										
<b>General</b>	<ul style="list-style-type: none"> <li>• Flanged mounting to stack ports</li> <li>• Transceiver/Reflector</li> <li>• Local control panel (standard specifications available, other specifications may be available)</li> <li>• Air purge assembly</li> </ul>										
<b>Calibration</b>	Calibration kit with 3 standards and carrying case included (on-site calibration or RATA by others)										
<b>Data Acquisition System</b>	Signal outputs sent to the incinerator PLC for display on the local HMI.										
<p><b>Integrated Weigh Scale</b></p> <p><i>Environment Canada’s Technical Document for Batch Incineration (March 2009) compliant accessory</i></p>	<p><b>Environment Canada’s Technical Document for Batch Incineration (March 2009) compliant accessory</b> for measuring the weight of waste materials charged to the incinerator. It is recommended that this device is installed near to the incinerator loading door. This can be in a small enclosure or the extra shipping container can be converted to allow for the scale to be installed inside.</p> <p>Weighing can be accomplished in one of two ways:</p> <ol style="list-style-type: none"> <li>1) <b>Weigh Scale Option 1 - simple light-duty portable electronic bench scale.</b> The Operator would be required to manually log and total the weights for record-keeping.</li> <li>2) <b>Weigh Scale Option 2 and 3 - heavy duty fully integrated electronic scale.</b> The package will be integrated with the incinerator so that it automatically logs and totals the weight and signals a cut-off when the maximum weight of waste has been reached.</li> </ol>										

INCINERATOR COMPONENT	DETAILS			
<p><b>Integrated Weigh Scale (cont..)</b></p> <p><i>Environment Canada's Technical Document for Batch Incineration (March 2009) compliant accessory</i></p>	<b>Note: <u>Option 2</u> is included in EWS Base Package already</b>			
		<b>Option 1</b>	<b>Option 2</b>	<b>Option 3</b>
	<b>Weighing Platform</b>	Above ground 2' x 2'	Low profile above ground 4' x 4'	Low profile above ground or in-ground mounting 4' x 4'
	<b>Capacity</b>	1000 lbs	5000 lbs	
	<b>Material of Construction</b>	Mild Steel platform and base (stainless steel available if required)		
	<b>Load Cells</b>	Standard load cells	Hermetically sealed (protection from dust, dirt and liquids)	
	<b>Weight Indicator</b>	Wall-mountable local indicator with IBN (Improved Black Pneumatic) display and IP69 enclosure (rated for temperatures from minus 10°C to plus 50°C).		
	<b>Integration</b>	None	Includes an analog output module (4-20mA) to send signal to the incinerator PLC. System HMI will display weigh scale data and weights will be logged automatically along with other incinerator functional parameters described herein.	
	<b>Coping/bumper frame to protect scale from damage</b>	N/A	N/A	Included
<b>Self-Alignment</b>	N/A	N/A	Self-aligning ball bearing suspension of scale	

## EWS DOCUMENTATION PACKAGE

---

The following list defines the EWS standard documentation package.

However, additional documentation can be provided but must be agreed upon and defined in the contract. Also, additional documentation may result in increased costs to the Buyer.

Also, if required, final drawings can be signed and stamped by Professional Engineer, at an additional cost to the Buyer.

DOCUMENT NAME	FORMAT	QUANTITY
<b>Production Schedule*</b>	Electronic PDF file	1
<b>ISO Quality Plan*</b>	Electronic PDF file	1
<b>ISO Inspection &amp; Test Plan</b>	Electronic PDF file	1
<b>Installation, Operation, Maintenance &amp; Training Operator Manual</b>	Hardcopy in 3-ring binder and files on a compact disc	2 binders, 2 CDs In English
<b>Equipment Layout Drawing – General Arrangement* with weights and dimensions</b>	Electronic PDF file	1
<b>Itemized Spare Parts Lists (if purchased)</b>	Electronic PDF file	
<b>Piping &amp; Instrument Diagram*</b>	Electronic PDF file	1
<b>Electrical Wiring Diagram</b>	Electronic PDF file	1

**Note:** Items highlighted with (\*) above are typically included in the preliminary documentation package which will be submitted to client at 2ARO (Two Weeks After Receipt of Order).

## EWS ITEMIZED BUDGETARY PRICING – BASIC PACKAGE

Item	Description	Unit Price \$CAD
1	<b>Eco Waste Oxidizer System Model: ECO 1.5TN 1P</b> <ul style="list-style-type: none"> <li>• As per technical specifications given herein</li> <li>• Includes EWS Documentation Package given herein</li> <li>• Includes Domestic Packaging as described herein</li> <li>• The bracing of incinerator components within the container</li> <li>• Loading the container onto Purchaser's nominated transportation supplier</li> </ul>	\$475,000
2	<b>Continuous Emissions Monitoring System (CEMS)</b>	\$26,250
3	<b>Start-up &amp; Training Package</b> <ul style="list-style-type: none"> <li>• 1 Technician, 7 days on-site for system installation check, system start-up and operator training</li> <li>• This is performed once assembly has been completed and photos have been provided to EWS</li> <li>• \$1500 per additional day on-site</li> </ul>	\$12,500
<b>Basic Package, EX Works Burlington, ON</b>		<b>\$513,750</b>

## EWS ITEMIZED BUDGETARY PRICING – OPTIONAL ITEMS FOR PURCHASE

Item	Description	Unit Price \$CAD						
1	<b>Recommended Commissioning Spare Parts Package</b>	\$4,109						
2	<b>Recommended Special Tools for Commissioning</b>	\$6,150						
3	<b>Recommended Operating Spare Parts Package for One (1) Year</b>	\$36,029						
4	<b>Recommended Capital Spare Parts Package</b>	\$23,800						
5	<p><b>Weigh Scale Options Note:</b> Option 2 is already included in EWS Total Equipment Package Price.</p> <p>Should client prefer to select Option 1 (a downgrade) or Option 3 (an upgrade) instead, EWS Total Equipment Package Price will be adjusted accordingly.</p> <p>Options are described on page 12 of this quotation</p>	<table border="1" style="width: 100%; border-collapse: collapse;"> <tr> <td style="text-align: center;"><b>Option 2</b></td> <td>Included in Total Basic Price</td> </tr> <tr> <td style="text-align: center;"><b>Option 1</b></td> <td>Reduce Total Basic Price by \$2877</td> </tr> <tr> <td style="text-align: center;"><b>Option 3</b></td> <td>Increase Total Basic Price by \$510</td> </tr> </table>	<b>Option 2</b>	Included in Total Basic Price	<b>Option 1</b>	Reduce Total Basic Price by \$2877	<b>Option 3</b>	Increase Total Basic Price by \$510
<b>Option 2</b>	Included in Total Basic Price							
<b>Option 1</b>	Reduce Total Basic Price by \$2877							
<b>Option 3</b>	Increase Total Basic Price by \$510							
6	<p><b>EWS Installation and Assembly Supervision Service Package</b></p> <ul style="list-style-type: none"> <li>• 1 Technician on-site 5 days to supervise equipment installation and assembly performed by buyer's local trades people</li> <li>• \$1500 per additional day on-site</li> </ul>	\$10,000						
7	<p><b>Domestic Transportation from Burlington, Ontario to Port Becancour, Quebec</b></p> <ul style="list-style-type: none"> <li>• 2 flatbed trucks</li> <li>• to ship one (1) x 40' container from EWS shop</li> <li>• to ship 2 incinerator chambers as bulk freight (tarped)</li> </ul>	\$8,500						

## EWS TECHNICAL ASSISTANCES RATES

<b>In-field Service &amp; Training Rate</b>	<b>Price (\$CAD)</b>	<b>Description</b>
Standard Rate	\$1,500.00	per day for standard ten (10) hour day (Monday to Friday)
Overtime Rate	\$225.00	per hour for weekdays (Monday to Friday) in excess of ten (10) hour per day
Non Working Days	\$225.00	per hour for Saturday ten (10) hour day
	\$300.00	per hour for Sunday or Holidays ten (10) hour day
Non Working Days Overtime Rate	\$450.00	per hour for Saturday, Sunday or Holidays in excess of ten (10) hours per day
Travel Time	\$650.00	per day Monday through Sunday
Travel Costs	TBD	Travel expenses charged out at cost + 10%
<b>Factory Training &amp; Assistance Rate</b>	<b>Price (\$CAD)</b>	<b>Description</b>
Standard Rate	\$900.00	per day for standard eight (8) hour day (Monday to Friday)
Overtime Rate	\$150.00	per hour for weekdays (Monday to Friday) in excess of eight (8) hour per day
Non Working Days	\$150.00	per hour for Saturday eight (8) hour day
	\$200.00	per hour for Sunday or Holidays eight (8) hour day
Non Working Days Overtime Rate	\$250.00	per hour for Saturday, Sunday or Holidays in excess of eight (8) hours per day

## EWS MAINTENANCE PACKAGES

EWS is committed to working with our customers to ensure that they have reliable, well-maintained equipment.

Therefore, we offer Maintenance Packages to help manage the total cost of ownership. Planned and budgeted service and maintenance costs are considerably less expensive and less difficult to manage than emergency repairs or impromptu service calls. The cost of a Maintenance service contract is generally outweighed by the costs of any downtime with unplanned emergency service calls.

With the purchase of a Maintenance Package we can also offer discounted technical assistance rates and training rates. For more details please request a quotation for an EWS Maintenance Package.

## EWS QUOTATION TERMS

---

1. Equipment quotation valid for 90 days
2. Excludes all applicable taxes, duties and tariffs
3. Subject to change in the event of errors and/or omissions
4. Budgetary Pricing is estimated at +/- 15%
5. Spare Parts Packages are *estimated* within this proposal. Upon receipt of signed Purchase Order and after completion of in-house detailed, engineering, EWS will provide itemized list with accurate pricing.
6. Domestic Transportation cost is *budgetary* and only *estimated* at this time. Upon receipt of signed Purchase Order and after completion of in-house detailed engineering, EWS will provide accurate domestic shipping costs.
7. EWS requires the full technical and commercial specifications to confirm compliance with all requirements. Upon review of full technical and commercial specifications, EWS will provide a list of any applicable exceptions and clarifications.

## ITEMS BY OTHERS: (not included in equipment price)

---

1. Site preparation (including concrete pad or other suitable level surface)
2. Off-loading and field-installation and assembly of incinerator
3. Building Enclosure for incinerator package
4. Fuel Tank and Waste Oil Tank
5. Piping & Fuel/waste oil delivery fillings systems
6. Electrical wiring and external conduit to the equipment to control panel from the Main Power feed
7. Final electrical terminations and power to junction boxes
8. low level switch to shut burner off when HWOB tank is empty
9. low level switch to shut burner off when diesel tank is empty
10. immersion hear in HWOB tank
11. stir mixer in HWOB tank
12. Applicable duties and/or taxes
13. Environmental permits, testing, bonding, local permits
14. Freight of equipment and materials to site, crane and forklift for off-loading equipment
15. Mobilization to and from Jobsite by EWS technicians (air travel, taxi etc.) and Room and Board on-site. To be billed separately.
16. Time for site specific safety orientation or other safety requirements such as Medical Exam (if required)

## **EWS PAYMENT TERMS**

---

**Eco Burn Inc. o/a Eco Waste Solutions** manufactures equipment on a custom order basis. Therefore, the Schedule of Payments is as follows:

- 15% Upon submission of deliverable: Documentation of Drawing Descriptions and anticipated submittal dates
- 35% Upon documented verification of placement of orders for major equipment
- 40% Following Purchaser Inspection and readiness to ship from Eco Waste Solutions Facility (Burlington, Ontario)
- 10% Systems commissioning or 90 days after readiness to ship whichever comes first.

Payment Terms are Net 30 days from Owner receipt of a correct and compliant invoice with required supporting documentation confirming achievement of milestone, where applicable.

## **EWS DELIVERY**

---

The ECO Model typically requires 20 weeks from receipt of Purchase Order (PO) and down payment.

## EWS ENVIRONMENTAL PERFORMANCE

---

**Eco Waste Solutions (EWS)** is a leader in providing environmentally responsible waste management equipment. EWS has certified air emissions test data proving that the equipment can reproducibly achieve the CCME (Canadian Council of the Ministers of the Environment) CWS (Canada Wide Standards). These limits can be met using the incinerator package, proposed herein, when processing the described waste in accordance, with factory recommended operating procedures.

Therefore, EWS will guarantee compliance of the Incinerator Package with the CCME emission limits for Dioxins and Furans specifically:

Pollutant	Limit
Dioxins & Furans	80 pg/ Rm3 TEQ

The incinerator package proposed herein, will also **comply with all requirements** contained in *Environment Canada: Technical Document for Batch Waste Incineration (March 2009)*.

***Please see datasheet for EWS explanation under sub-section “Emission Criteria”.***

The waste types to be processed are considered non-hazardous and it is assumed that any/all hazardous waste materials including batteries will be eliminated from the incinerator waste stream. The waste types to be processed are typical of camp waste and should not include any heavy metals or other problematic compounds.

However, to avoid exhaust emissions containing Mercury, materials that may contain heavy metals such as batteries MUST be eliminated from the incinerator waste stream. It is important that waste segregation and tracking procedures are in place whenever waste is to be incinerated and meet the regulations specified. Heavy metals in the exhaust emissions are not controlled by incinerator design but rather by waste control practices.

Therefore, **NO guarantee** is included herein, for any METALS (Mercury, Arsenic, Cobalt, Chromium, Copper, Manganese, Nickel, Cadmium, Lead and Thallium). All metals have been left out of the scope of the guarantee as they are not controlled by the equipment but rather a function of the waste input. If waste is properly segregated emissions will be well below those given as limits.

**Note:** If these waste-streams containing heavy metals, cannot be avoided, *Air Pollution Control equipment (Scrubber)* must be added to the incinerator package (pricing for this additional equipment can be provided, upon request).

Regardless, to ensure a high standard of performance from the incinerator package, it is important that the following practices are followed;

- waste segregation and tracking procedures are in place whenever waste is to be incinerated,
- operators are properly trained and follow all recommended operating procedures
- incinerator equipment is properly maintained.

Ultimately, the incinerator system operator is responsible to ensure that the correct waste is processed; the equipment is properly operated and maintained, according to recommended schedules, to avoid causing unwanted air emissions.

## **EWS ENVIRONMENTAL PERFORMANCE (CONTINUED...)**

---

### **Air Emission Performance Conditions**

1. The owner / operator is responsible for preventative measures to eliminate any waste from being fed into the incinerator that contain heavy metals.
2. The owner / operator is responsible to ensure that waste treated is only as per specified.
3. The unit must be operated within the rated operating ranges according to instructions and ensuring that the incinerator is not overloaded.
4. The owner / operator will ensure that each chamber is not charged with any load weighing greater than stated capacity or 75-80% of the chamber's internal capacity by volume per burn cycle (as indicated by the lowest aspect of the opening of the of the breach, or the burner port of the Primary Chamber). The chamber volumes are calculated to provide enough space for the total weight at the assumed density in the area below the burner port
5. The owner and/or operators are responsible for installing and operating the unit according to the manufacturer's instructions.
6. Operator must not create excess air and particulate emissions by stoking of the waste bed during burning or continuous feeding. Both actions are not acceptable.
7. The owner / operator is responsible for ensuring the safe operation of the unit, according to procedures outlined in the owner's manual and including good housekeeping practices such as ash cleanout prior to re-loading the unit.
8. The unit must be maintained according to the Eco Waste Maintenance Schedule. This should be documented fully including evidence of parts replacement.
9. Modification, abuse or other impairment of the unit voids all warranties and equipment performance obligations by Eco Waste Solutions.

If these conditions are not met Eco Waste Solutions (EWS) cannot assure the performance of the unit as designed.

If air emissions testing is required, the testing procedure is to be mutually agreed upon and performance testing to be performed within 60 days of start-up or 120 days after shipment, whichever occurs first. In the event that testing is delayed beyond this period through no fault of EWS, EWS shall be relieved from all obligations.

In the event that the equipment does not meet the performance targets EWS has committed to, EWS has the option at its own expense to make adjustments or additions to the equipment, to ensure that compliance can be met. The performance testing fees for the services of a certified testing lab and any costs associated with the testing (rental of equipment, or provision of an Eco Waste Technician to be present at testing etc.) are not included with the price of equipment or services.

## EQUIPMENT WARRANTY

---

### Equipment Warranty

To the original Purchaser, **EWS** warrants that the products and parts manufactured by the Corporation and supplied hereunder shall be free from defective workmanship and material for a period of 18 months from notice of ready to ship or 12 months from start-up at Purchaser's site, whichever is less. **EWS'** warranty is limited to **EWS** supplying the Purchaser with parts F.O.B. Purchaser site, replacement of any product or parts which shall be proved to the Corporation to be defective, provided that the Purchaser gives notice in writing within three (3) days after defect discovery.

To provide all labour related to **EWS** manufactured / warranted parts for 18 months from notice of ready to ship or 12 months from start-up whichever is less. In the case where **EWS** has purchased components from other vendors or suppliers, warranty will be limited to providing, render reasonable assistance to Purchaser when requested, in order to enable Purchaser to enforce such warranties and guarantees by third party manufacturers suppliers.

### Equipment Covered by Warranty

Equipment supplied under a purchase order to **EWS** including:

- Primary and Secondary Chamber
- Connecting ductwork between Primary and Secondary Chambers (Breach Sections) and the Stack Sections
- Controls – Manual, Electronic and Electric

### Extent of Warranty Coverage

All costs related to the repair or replacement of system components where failure is due to defect in material, workmanship or design is covered by **EWS** for one year from the date of repair or replacement.

Replacement due to abuse, misuse, and/or lack of maintenance or carelessness is not covered. Wear from normal use, or alternative disposal costs are not covered.

There is no warranty on the following parts and/or any consumables:

- All burner flame-front parts
- Thermocouple elements + protection tubes
- Electrodes, photocells
- Gaskets, Seals and tubing
- Fuses, light bulbs and glass assemblies
- Nozzles, filters
- Refractory Surface Cracks\*
- Tubing

\*Note: Normal in high temperature applications

### Warranty Provisions and Exceptions

**EWS** does not guarantee or warrant, either expressly or implied, the materials and workmanship of supplies, materials, equipment or machinery manufactured by third parties and furnished and installed by **EWS** (outside of the scope of this proposal) in the performance of the Work, to the extent such supplies, materials, and equipment or machinery is itself an end product with its own customary warranty.

**EWS** shall endeavor to obtain from all such vendors and suppliers and assign to Purchaser the customary warranties and guarantees of such vendors and suppliers with respect thereto. **EWS** shall, at the sole expense to Purchaser, render reasonable assistance to Purchaser when requested in order to enable Purchaser to enforce such warranties and guarantees by third party manufacturer's suppliers.

**EWS** will not be liable for any consequential damages, loss or expense arising from any change in or alteration to equipment of its manufacturer such changes or alterations having been made by any persons other than personnel of **EWS** or its agents, in which event such agents must have written permission of **EWS** prior to making such changes or alterations.

**EWS** shall in no event, be liable for consequential damages as a result of any breach of this agreement by or for any other reason. This warranty shall not apply to products or parts not manufactured by **EWS** or to equipment parts which shall be subject negligence, accident or improper control, improper operation, maintenance, storage, or damage or circumstances beyond the control of **EWS** or to other than normal use or service. Regarding parts of the equipment purchased by **EWS**, no warranty is made other than that offered by the original equipment manufacturer.

THE ABOVE ARE **EWS'** SOLE WARRANTIES, AND THE REMEDIES SET FORTH ABOVE CONSTITUTE PURCHASER'S EXCLUSIVE REMEDIES IN THE EVENT SUCH WARRANTIES ARE BREACHED. WITH RESPECT TO THE CONSTRUCTION AND MECHANICAL FUNCTION OF THE PRODUCTS, **EWS** MAKES NO OTHER WARRANTIES OF ANY KIND WHATEVER, AND THESE WARRANTIES ARE IN LIEU OF ALL OTHER WARRANTIES OR GUARANTEES, WRITTEN OR ORAL, STATUTORY, EXPRESS OR IMPLIED, INCLUDING WITHOUT LIMITATION THE WARRANTY OF MERCHANTABILITY AND THE WARRANTY OF FITNESS FOR A PARTICULAR PURPOSE.

## Acceptable Waste-Streams

The **Eco Waste Solutions Waste Oxidizer** can process a range of waste materials. The following list has some of the potential waste streams that can be effectively processed in our system. This list is only a guide and should not be assumed to be an exhaustive list of materials. Please contact EWS for more details.

### Acceptable Waste Materials Suitable for Processing in Eco Waste Solutions Technology

<b>Solid Waste</b>	<b>Description</b>	<b>Origin</b>
Food Waste	Food, food packaging and containers, plastic and paper waste from food preparation	Kitchen and dining areas
Domestic waste	General refuse such as paper, plastics, cans, bottles, cardboard, newsprint	Dormitory areas, recreation facilities, office areas, warehouse, plant and production facilities
Packaging	Cardboard boxes, paper, plastic containers, plastic film, styrofoam, poly-weave bags	Inbound supplies to all work areas.
Wood waste	Skids, pallets, crates, including wood materials contaminated with chemical residues from Cyanide or explosives	Construction activity, inbound supplies, reagent and chemical packaging.
Absorbents	Rags, wipes, spill cleanup materials	From all work areas
Filters – Air and Fluid	Filters coated with fine particles and trapped solids, saturated with water or fluids (glycol, lube oils, fuel)	From water treatment facility, or generated at point of maintenance of vehicles, machinery and equipment
Medical Waste	Bandages, dressings, gloves, swabs, syringes, sharps	Medical clinic or first aid centre
Tires & Rubbers	Tires, belts, hoses	From vehicles and equipment maintenance shop
Low-level radioactive waste <sup>1</sup>	Personal protective equipment (gloves, overalls, etc.), pallets, packaging, rags, construction debris that have come in contact with radioactive elements.	From maintenance activities, operations and construction activities
<b>Liquid Waste<sup>2</sup></b>	<b>Description</b>	<b>Origin</b>
Glycol	Used antifreeze	From vehicles and equipment maintenance shop
Used Oils	Used lubricating and hydraulic oils, including synthetics	From vehicles and equipment maintenance shop
<b>Semi-solid Waste<sup>3</sup></b>	<b>Description</b>	<b>Origin</b>
Sewage sludge	Dry filter cakes	From sewage treatment plant dewatering equipment
Kitchen grease, oils	Solid kitchen fats, grease, used cooking oil	Kitchen grease traps, fryers

**Note: the following items require special features and handling please consult with EWS for details**

1. Processing of radioactive materials requires the inclusion of an air pollution control system.
2. Glycol can be blended with waste oil (up to 5%) – only with optional upgraded waste oil burner package.
3. Dewatered sewage sludge and kitchen grease can be comingled with waste – restrictions apply.

## Unacceptable Waste-Streams

The following is a list of some of the waste-streams that should not be processed in the Eco Waste Oxidizer. This list is only a guide and should not be assumed to be an exhaustive list of materials. Please contact EWS for more details and to discuss your specific waste processing requirements.

A waste and procurement audit is highly recommended and encouraged to ensure that all sources of heavy metals are identified and diverted to other disposal methods. Small amounts of materials containing heavy metals may be acceptable if air pollution control equipment specially designed for metals removal is included with the package.

### Unacceptable Waste Materials - NOT Suitable for Processing in Eco Waste Solutions Technology

Solid Waste	Description	Origin
Bulky Materials	Automotive or heavy equipment parts such as engine blocks and transmissions	From vehicles and equipment maintenance shop
Non-Combustible Materials	Drywall, asbestos, bricks, concrete, soils	Construction activity
Radioactive Materials	Smoke detectors, laboratory wastes	From Buildings, laboratories
Potentially Explosive Materials	Aerosol spray cans, large propane tanks, other pressurized vessels. Actual explosives	From warehouse, plant and production facilities
Heavy Metals	Items containing lead, mercury, cadmium, for example: batteries, electronic devices, fittings, old pipe work, fluorescent light bulbs, electrical switches, thermometers, PVC plastics, aluminum solder, photovoltaic cells	From maintenance activities, operations and construction activities
Liquid Waste	Description	Origin
High Alkaline or High Acid Materials	By-products of industrial processes, unrefined fuels	From warehouse, plant and production facilities
Solvents	Solvents such as acetone, xylene, methanol	From vehicles and equipment maintenance shop

Project: Meliadine Feasibility Study  
 Project No.: 5287063 - PM0014/6509  
 ECO 1.5TN1P

Commissioning Spares

### Commissioning Spare Parts

Qty	Part	Part No.*	EWS Spare CAD	EWS Spare Total CAD	Approx Lead Time (Weeks)
<b>Insulation</b>					
3	Blanket Refractory (50 sq ft)	502614	\$250.00	\$750.00	2-3
2	Super 3000 Mortar	SM 3000	\$89.00	\$178.00	2-3
<b>Primary burner - RL 28/2</b>					
2	Filter	3003082	\$30.00	\$60.00	2-3
4	Nozzle	C5222445	\$15.00	\$60.00	1
4	High Temperature Leads	3012995	\$17.00	\$68.00	1
<b>Secondary Burner - RL 130/M</b>					
4	Nozzles Modulating	C5220111	\$85.00	\$340.00	1
4	High Temperature Leads	3012959	\$25.00	\$100.00	1
<b>Burners - Primary &amp; Secondary</b>					
8	Electrode	3003796	\$29.00	\$232.00	1
4	PE Cell	3006216	\$210.00	\$840.00	2-3
<b>High Output Waste Oil Burner</b>					
4	O'rings	JXPL Viton Extension	\$4.00	\$16.00	2-4
4	Washers	JPL 316 SS Rear Washer	\$33.00	\$132.00	2-4
4	Gaskets	JPL 316 SS Gasket	\$33.00	\$132.00	2-4
<b>Fuse</b>					
3	Class J 600V 30 Amp fuse	LPJ-30SP	\$18.00	\$54.00	1
3	Class J 600V 15 Amp fuse	LPJ-15SP	\$11.00	\$33.00	1
6	Class J 600V 10 Amp fuse	LPJ-10SP	\$11.00	\$66.00	1
3	Class J 600V 6 Amp fuse	LPJ-6SP	\$11.00	\$33.00	1
1	Class J 600V 5 Amp Fuse	LPJ-5SP	\$11.00	\$11.00	1
1	Class RK1 250V 25 Amp fuse	LPN-RK-25SP	\$7.00	\$7.00	1
2	Class RK1 250V 15 Amp fuse	LPN-RK-15SP	\$7.00	\$14.00	1
1	Class RK1 250V 10 Amp fuse	LPN-RK-10SP	\$7.00	\$7.00	1
2	Class RK1 250V 6 Amp fuse	LPN-RK-6SP	\$7.00	\$14.00	1
1	Class RK1 250V 5 Amp fuse	LPN-RK-5SP	\$7.00	\$7.00	1
1	Class RK1 250V 2 Amp fuse	LPN-RK-2SP	\$7.00	\$7.00	1
2	Class RK1 250V 1 Amp fuse	LPN-RK-1SP	\$7.00	\$14.00	1
<b>Miscellaneous</b>					
2	Type K Thermocouple element	TK-K08B-010.0-000	\$30.00	\$60.00	2-4
2	Inconel Protection Tube 10"	MP-60140-08-10.0	\$155.00	\$310.00	2-4
100	Thermocouple Wire (m)	Type K	\$5.00	\$500.00	1
1	Air Proving Switch	SML 8221210034	\$64.00	\$64.00	2-4
<b>Total</b>			<b>\$1,185.00</b>	<b>\$4,109.00</b>	

\*Part numbers and pricing subject to change upon detailed engineering.

## Operating Spare Parts for 1 Year Opeartion

Qty	Part	Part No.*	EWS Spare CAD	EWS Spare Total CAD	Approx Lead Time (Weeks)
<b>Insulation</b>					
8	Module Refractory (boxes)	433026	\$385.00	\$3,080.00	2-3
50	Door Gasket	462007	\$24.00	\$1,200.00	1
<b>Primary Burner - RL 28/2</b>					
1	Fan Motor	3012994	\$450.00	\$450.00	3-4
10	Nozzle	C5222445	\$15.00	\$150.00	1
10	Electrode	3003796	\$29.00	\$290.00	1
2	Diffuser Disc	3003791	\$62.00	\$124.00	2-3
1	Supply Tube	3003821	\$24.00	\$24.00	2-3
1	Return Tube	3003822	\$19.00	\$19.00	2-3
1	Oil Pump	3013027	\$257.00	\$257.00	3-4
10	HT Leads	3012995	\$25.00	\$250.00	1
1	U-Bolts	3003495	\$28.00	\$28.00	2-3
1	Support	3003813	\$20.00	\$20.00	2-3
1	Coil	3006767	\$51.00	\$51.00	2-3
2	End Cone	3003807	\$119.00	\$238.00	2-3
1	Shutter	3003805	\$55.00	\$55.00	2-3
1	Nozzle Holder	3003814	\$49.00	\$49.00	2-3
1	PE Cell	3006216	\$205.00	\$205.00	2-3
<b>Secondary Burner - RL 130/M</b>					
1	Fan Motor	3012943	\$844.00	\$844.00	3-4
10	Nozzle	C5220111	\$59.00	\$590.00	1
10	Electrode	3003796	\$23.00	\$230.00	1
2	Diffuser Disc	3012463	\$96.00	\$192.00	2-3
1	Supply Tube	3012470	\$79.00	\$79.00	2-3
1	Return Tube	3012471	\$79.00	\$79.00	2-3
1	Oil Pump	3006369	\$749.00	\$749.00	3-4
10	HT Leads	3012959	\$23.00	\$230.00	1
1	U-Bolts	3003495	\$28.00	\$28.00	2-3
1	Support	3012461	\$71.00	\$71.00	2-3
1	Coil	3006767	\$51.00	\$51.00	2-3
1	Pressure Switch	3012948	\$253.00	\$253.00	2-3
2	End Cone	3012469	\$198.00	\$396.00	2-3
1	Shutter	3003984	\$87.00	\$87.00	2-3
1	Connector (nozzle holder)	3012096	\$597.00	\$597.00	2-3
1	PE Cell	3006216	\$205.00	\$205.00	2-3
<b>High Output Waste Oil Burner</b>					
1	Safety Relief Valves	VJ-3R 30-100	\$506.00	\$506.00	1
1	Liquid Level Switch	FS301-01	\$920.00	\$920.00	1
1	Pressure Switch	B724T 30 psi	\$1,125.00	\$1,125.00	2-3
1	Temperature Switch	ARR1264	\$620.00	\$620.00	2-3
1	Oil Pressure Gauge	0-60 psi	\$93.00	\$93.00	2-3
1	Ball Valves	#3080	\$38.00	\$38.00	3-4
1	Flow Control Valve	1813-02A-K	\$861.00	\$861.00	1
1	Back Pressure Regulator	98H-45	\$4,238.00	\$4,238.00	2-3

Project: Meliadine Feasibility Study  
 Project No.: 5287063 - PM0014/6509  
 ECO 1.5TN1P

Operating Spare Parts

1	Regulator	1115-8	\$178.00	\$178.00	2-3
8	Air Tubes	4-3684-2	\$290.00	\$2,320.00	2-3
1	Air Tube & Nozzle Assembly	3-6076-2	\$1,290.00	\$1,290.00	2-3
1	Mounting & Tile Assembly	3-6668-2	\$1,960.00	\$1,960.00	2-3
1	Oil Tube	3-2515-1	\$575.00	\$575.00	2-3
1	Oil Nozzle	3-6088-1	\$1,580.00	\$1,580.00	2-4
<b>Starters</b>					
1	9 Amp IEC Contactor	100-C09D10	\$66.00	\$66.00	2-4
1	Auxiliary Contact Block	100-FA40	\$51.00	\$51.00	2-4
<b>Overloads</b>					
1	IEC solid state overload relay range 1- 5 a	193-EECB	\$76.00	\$76.00	1-2
<b>Relays</b>					
1	Relay	700-HK36A1	\$18.00	\$18.00	1-2
1	Relay	700-HN121	\$12.00	\$12.00	1-2
<b>Switches</b>					
2	Limit Switch	802T-A	\$133.00	\$266.00	1-2
<b>PLC</b>					
1	16 Point AC Input Card	1769-IA16	\$374.00	\$374.00	2-3
1	16 Point AC Output Card	1769-OW16	\$574.00	\$574.00	2-3
1	4 Channel Analog Input Card	1769-IF4	\$646.00	\$646.00	2-3
1	6 Channel Thermocouple Input Card	1769-IT6	\$1,311.00	\$1,311.00	2-3
1	8 Channel Analog Output Card	1769-OF4	\$1,933.00	\$1,933.00	2-3
<b>Miscellaneous</b>					
10	Type K Thermocouple element	TK-K08B-010.0-000	\$30.00	\$300.00	2-3
10	Inconel Protection Tube 10"	MP-60140-08-10.0	\$155.00	\$1,550.00	2-3
1	Draft Transmitter	616KD-00	\$134.00	\$134.00	2-3
3	Air Proving Switch	SML 8221210034	\$64.00	\$192.00	2-3
1	Modutrol	M9184D4009	\$962.00	\$962.00	2-3
1	Resistor Kit	0-20 mA	\$1.00	\$1.00	2-3
1	Modutrol Transformers	50017460-001	\$88.00	\$88.00	2-3
<b>Total</b>			<b>\$26,161.00</b>	<b>\$36,029.00</b>	

Project: Meliadine Feasibility Study  
 Project No.: 5287063 - PM0014/6509  
 ECO 1.5TN1P

Capital Spares

### Capital Spare Parts

Qty	Part	Part No.*	EWS Spare CAD	EWS Spare Total CAD	Approx Lead Time (Weeks)
<b>Primary Burner RL 28/2</b>					
1	Primary Oil Burner	RL 28/2	\$3,400.00	\$3,400.00	3-4
<b>Secondary Burner - RL 130/M</b>					
1	Secondary Oil Burner	RL 130/M	\$7,610.00	\$7,610.00	3-4
<b>High Output Waste Oil Burner</b>					
1	Gear Pump	3HB1131-5TE32	\$2,900.00	\$2,900.00	3-4
1	10Hp Motor	CT10-D36	\$3,200.00	\$3,200.00	2-3
<b>PLC</b>					
1	<b>PLC Power Supply</b>	1769-PA2	\$680.00	\$680.00	2-4
1	Processor	1769-L32	\$3,701.00	\$3,701.00	2-4
<b>DC Power Supply</b>					
1	24 VDC 1.3 Amp Power Supply	PS5R-SC24	\$59.00	\$59.00	1-2
<b>Frequency Drives</b>					
1	480 volt 3 H.P. V.F.D.	22A-D6P0N104	\$2,250.00	\$2,250.00	2-4
			<b>Total</b>	<b>\$23,800.00</b>	

Project: Meliadine Feasibility Study  
 Project No.: 5287063 - PM0014/6509  
 ECO 1.5TN1P

Special Tools

### Special Tools

Qty	Part	Part No.*	EWS Spare CAD	EWS Spare Total CAD	Approx Lead Time (Weeks)
1	Stud Gun	STMOD	\$ 5,175.00	\$ 5,175.00	4-5
1	Incinerator Clean Out Kit	ECSS2344	\$ 975.00	\$ 975.00	4-5
			<b>Total</b>	<b>\$ 6,150.00</b>	



Project: Meliadine Feasibility Study  
Project No.: 5287063 - PM0014/6509  
ECO 1.5TN1P

Special Tools

**MELIADINE FEASABILITY STUDY****Technical Datasheet****Incinerator****AGNICO EAGLE**

	DESCRIPTION	UNITS	TECHNICAL DATA
<b>Identification</b>			
	Equipment name		Incinerator
	Equipment number		65FCA04001
<b>General</b>			
	Supplier		Eco Waste Solutions
	Manufacturer		Eco Waste Solutions
	Model number		ECO 1.5TN1P100L
<b>Service Conditions</b>			
	Location		Nunavut
	Altitude	m	62
	Design ambient temperature	°C	5 to 40 (inside building)
	Operation		7 days/week
<b>Incinerator</b>			
<b>Design Criteria</b>			
	Number of units		1
	Type		Dual Chamber
	<b>Capacity</b>	<b>kg / batch</b>	<b>1500</b>
	Productivity	batch / d	1
	Fuel type		Diesel, Winter Diesel and Waste Oils
	Primary chamber temperature	°C	~ 650 to 850
	Secondary chamber temperature	°C	> 1000
	Secondary chamber retention time	s	> 1
	Equipment weight	kg	24500
<b>Acceptable Solid Waste for Incineration</b>			
	Organic matter (including food)		
	Food containers and wrappings (including plastic that is not contaminated by food)		
	Paper		
	Wood		
	Sewage sludge --- max: 200 kg/day		
	Waste oils (shall be used as fuel) --- approx. 1000 l/day		
<b>Components &amp; Features</b>			
	Refractory lining		EWS standard supply of refractory is a combination of durable resilient refractory (castable and ceramic modules) as this material is more reflective (thus saves fuel), cools down quickly and is not susceptible to thermal shock)
	Burners		Riello/ RL28/2, Riello/ RL100/M, Fives North American/6422
	Blowers		NY Blower/Junior 90, SWSI 15, Fives North American/CT10-D36T1SI
	Coupling & Guards		Shall be included
	Exhaust piping/stack system		Shall be included
	Stack		EWS standard supply for the stack is 1/4" mild steel welded and refractory lined - 11 m From Grate
	Spark arrester on incinerator stack		Shall be included
	Fuel supply system with day tank		Excluded
	Waste Oils day tank and supply system		Excluded
	Fuel train (including fuel control valve)		Shall be included (to FM standards)
	Paint		Heat resistant



MELIADINE FEASABILITY STUDY

Technical Datasheet

Incinerator



AGNICO EAGLE

	DESCRIPTION	UNITS	TECHNICAL DATA
	Maintenance access doors		On each chamber there is an access door for maintenance purposes. The door on the Primary Chamber is used for loading material, removing ash and for maintenance purposes.
<b>Emission Criteria</b> (all emissions standardized at 11% O2)			
	Particulate matters	mg/Rm <sup>3</sup>	< 20 (the incinerator proposed can operate at this limit, however to provide an EWS Performance Guarantee, we recommend the purchase of an Air Pollution Control system to be integrated with the package.
	Dioxins & furans	pg / Rm <sup>3</sup> TEQ	< 80
	Carbon monoxide (CO)	mg/Rm <sup>3</sup>	< 57
	NOx	mg/Rm <sup>3</sup>	< 500
	Opacity		< 5%
<b>Electrical and Control Options</b>			
	Power supply	V/ph/Hz	600 / 3 / 60
	Electrical load	kW	10.5
	Local control panel		NEMA 4
	Air/fuel modulation		Yes
	Temperature monitoring		Yes
	Temperature control system		Yes
	Safety shut-off on burner fail		Yes
	Monitoring /data acquisition system		Compliant with Environment Canada's Technical Document for Batch Incineration (March 2009). Please see document enclosed in EWS Submittal for full document.
	Remote I/O		EWS Standard Scope of Supply is a local control panel. All incinerator components are installed within 50' feet of the Main Control Panel. Buyer can use its Plant Control System to monitor the incinerator provided the exact same software is integrated (software purchase or upgrades may be required)
	Equipment operation		Local only

BILL OF MATERIAL			
ITEM	QTY.	DESCRIPTION	WEIGHT LB(Kg)
1	1	PRIMARY CHAMBER	22500(10206)
2	1	SECONDARY CHAMBER	18080(8200)
3	1	PRIMARY BURNER	88(40)
4	2	SECONDARY BURNER	176(80) x2
5	1	PRIMARY BLOWER ASSEMBLY	275(125)
6	1	SECONDARY BLOWER ASSEMBLY	551(250)
7	1	BREECH ASSEMBLY	1005(455)
8	5	STACK SECTIONS	1720(780) X5
9	1	BAROMETRIC DAMPER ASSEMBLY	480(218)
10	2	AIR EMISSIONS TEST PORTS	-
11	1	MAIN CONTROL PANEL	507(230)
12	1	WASTE OIL BURNER	-
13	1	WASTE OIL FUEL TRAIN SKID	-
14	1	WASTE OIL BURNER BLOWER	-
15	1	WASTE OIL PUMPING SKID (LOCATION TBD)	-
16	1	SPARK ARRESTOR	-
17	1	SECONDARY BURNER PLATFORM	-

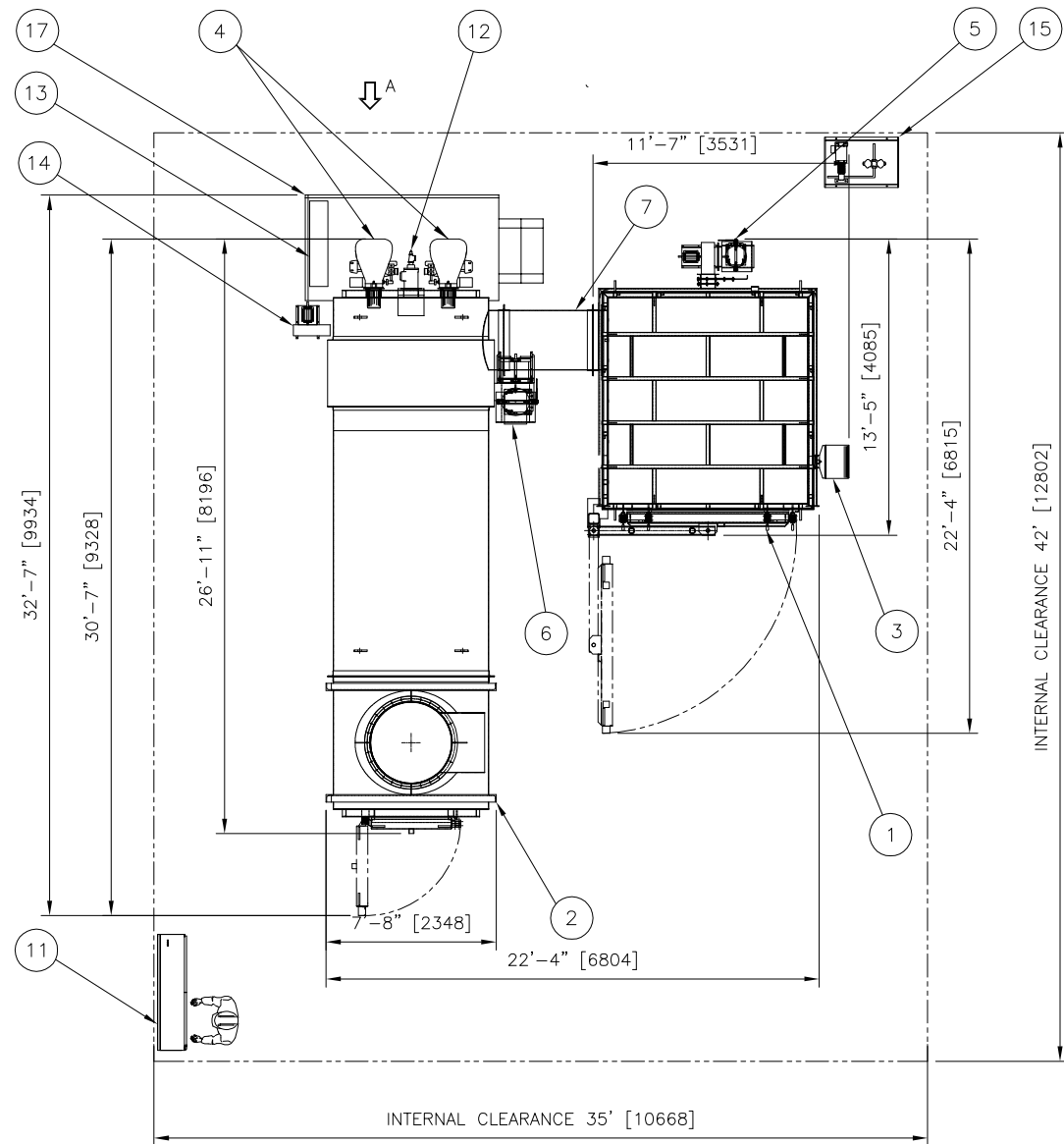

PLAN VIEW

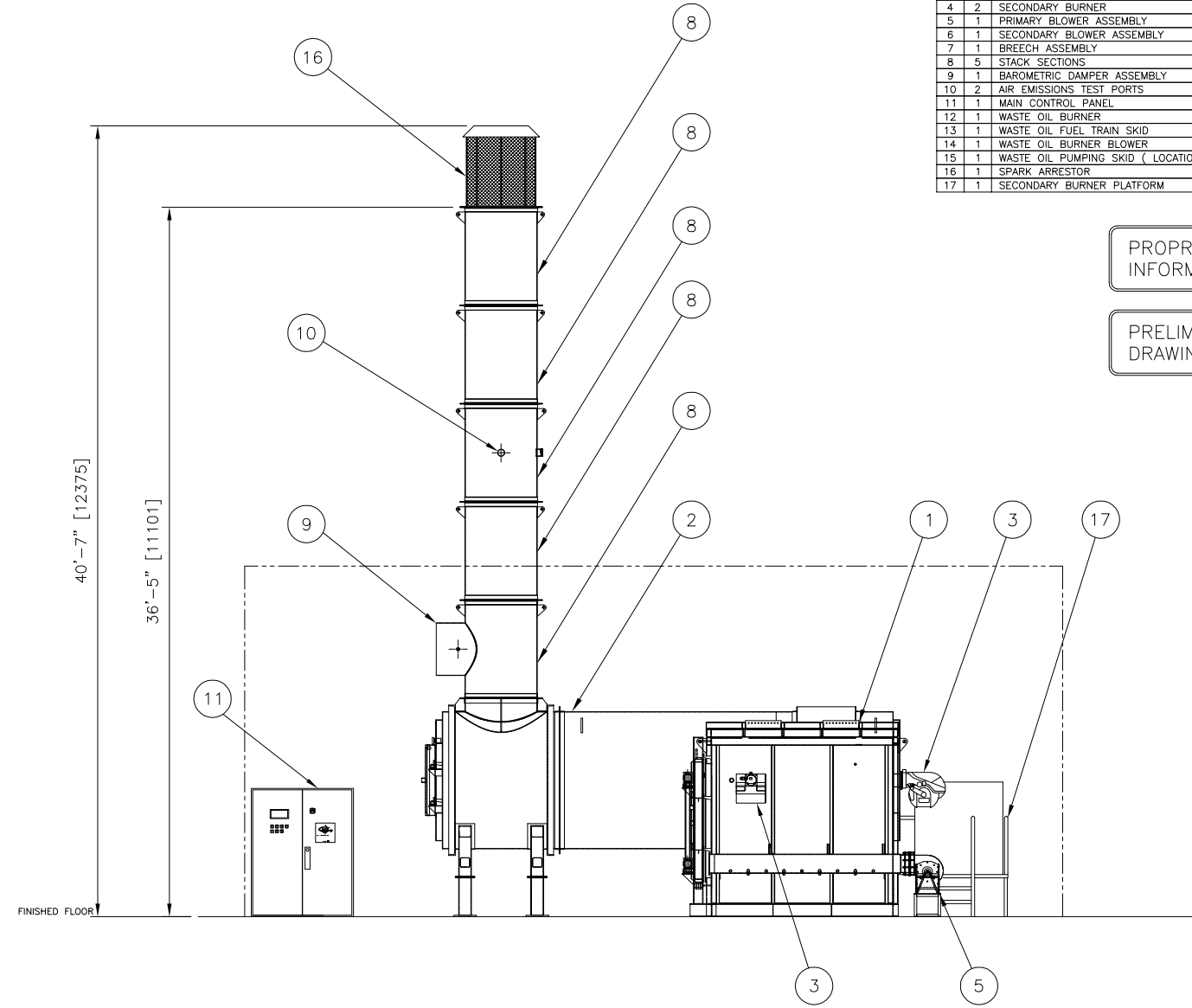

RIGHT ELEVATION

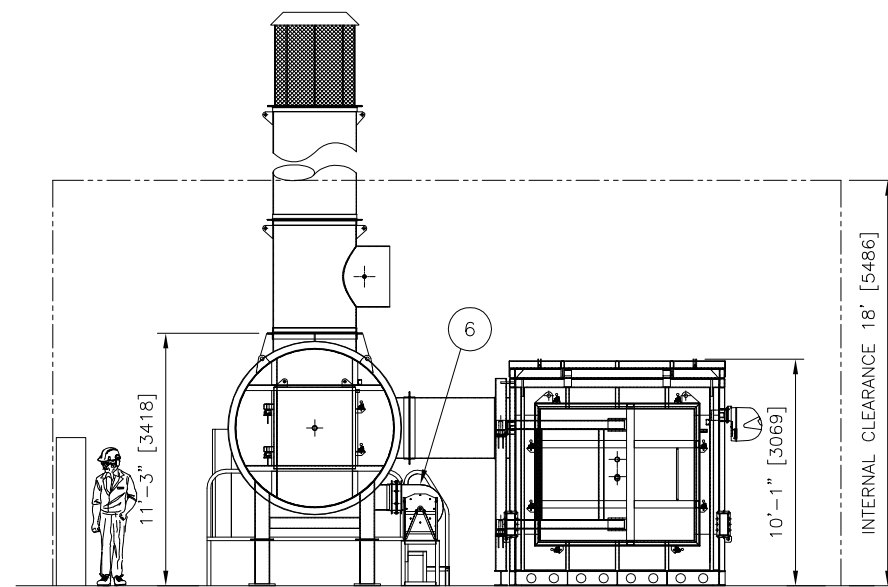

FRONT ELEVATION

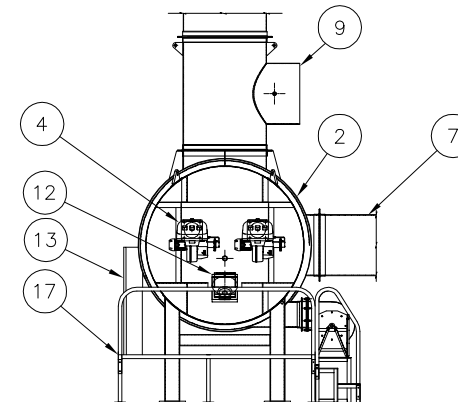

VIEW ON A (BACK VIEW)

PROPRIETARY INFORMATION  
PRELIMINARY DRAWING

REV.	DATE	DESCRIPTION	BY	APPROVED
THIS DOCUMENT IS THE PROPERTY OF ECO BURN INC. AND SHALL NOT BE USED, COPIED OR TRANSFERRED TO OTHER DOCUMENTS WITHOUT PRIOR WRITTEN PERMISSION OF ECO WASTE SOLUTIONS.				
DRAWN:	DATE:			
JX	20 AUG 2014			
CHECKED:	DATE:	PROJECT NAME: MELIADINE		
KD	21 AUG 2014	PROJECT NUMBER:		
SCALE: 1:50		TITLE: GENERAL ARRANGEMENT ECO 1.5TN1P100L		
JOB NO.		CUSTOMER P.O.		
THIRD ANGLE		CUSTOMER EQUIPMENT. #		
DWG. NO. EC01.5TN1P100L-00		REV. A		



**SUPPLIER NAME: ECO WASTE SOLUTIONS**

ITEM No.	ITEM DESCRIPTION	QUANTITY	EACH PIECE APPROXIMATE					
			Length		Width		Height	
	<b>ECO 1.5 TN 1P100L INCINERATOR</b>	<b>1</b>						
<b>1</b>	Primary Chamber	<b>1</b>	12 3.6	FT M	10 3.2	FT M	10 3.07	FT M
<b>2</b>	Secondary Chamber	<b>1</b>	25 7.52	FT M	8 2.46	FT M	9 2.8	FT M
<b>3</b>	40' ISO Shipping Container Including	<b>1</b>	40	FT	8	FT	8	FT



### EWS List of Incinerator Defaults Controls & Alarms

#### Incinerator's Default Controls:

1. Emergency Stop button (E-Stop)
2. Control Power On illuminated push button
3. HMI displays temperature readings, damper position, state(open-closed, on-off) of doors, blowers and burners.
4. HMI has Start / Stop push buttons for burn cycle and clear alarm button.
5. HMI displays historical logging of incinerator temperature.
6. HMI displays system alarms.

#### Default Alarms:

#	ALARM (System Fault)
1	The Primary Chamber Thermocouple is faulted
2	The Secondary Chamber thermocouple is faulted
3	The Secondary Stack Thermocouple is faulted
4	The primary burner is faulted
5	The secondary burner is faulted
6	The system has shut down due to primary blower low air flow.
7	The primary blower motor overload is tripped.
8	The system has shut down due to secondary blower low air flow
9	The Secondary blower variable frequency drive is faulted
10	Low burner fuel level

## **APPENDIX II**

### **Operating Manual of the Composter**



# Brome Composter

## Instruction Manual

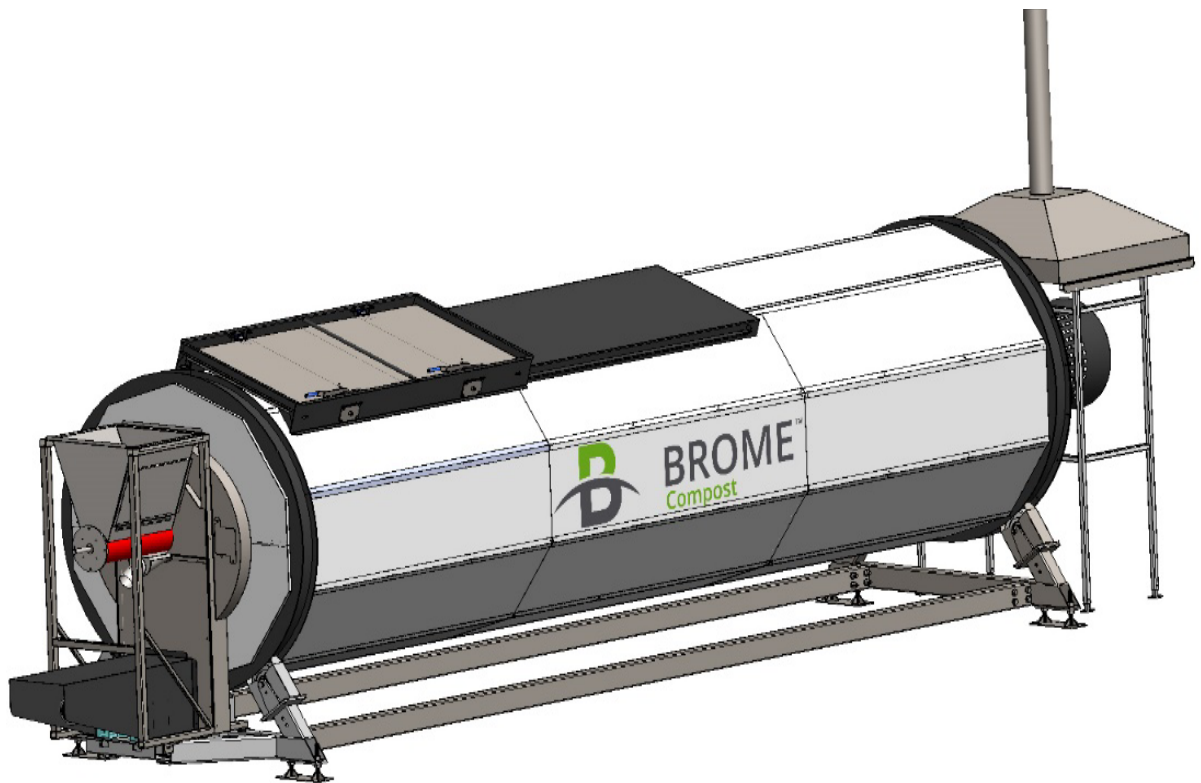

## Operator Manual

**Before using this composter, please be sure to carefully read the following instructions and become familiar with its operation in order to prevent problems and accidents.**



### **INTRODUCTION**

Composting is the ideal solution for the disposal of organic waste, especially when the alternative is sending it to landfill sites. Composting on-site greatly reduces greenhouse gas emissions and atmospheric pollutants related to the transport of organic residual matter to landfills or to industrial composting sites.

Brome Composters are easy to install and use. They have low operating costs and low maintenance requirements, making on-site composting accessible to many types of industries, commercial business and institutions (ICI), as well as farms and municipalities.

Brome Composters are designed to convert many types of organic waste including food scraps, animal products, green waste, animal carcasses, septic mud, etc., into high-quality compost in a short period of time and with little handling. Brome Composters are available in a variety of different models, which can easily be adapted to the user's needs.

#### **Models :**

Composter 400 Series	Brome 406 Brome 410 Brome 416 Brome 424 Brome 430
Composter 500 Series	Brome 506 Brome 510 Brome 516 Brome 524 Brome 530
Composter 600 Series	Brome 608 Brome 616 Brome 624 Brome 630

Model: (capacities can vary depending on the type of material, the required residency time, and whether the input is pre-treated).

The composter is an insulated cylinder that self-rotates according to the user's pre-set time intervals. These rotations mix the contents while at the same time providing aeration, allowing the bacteria to breathe and break down the organic waste (O.W.) into compost more rapidly than other composting methods. The decomposition process produces heat. The cylinder is insulated with a 1½" insulating material (R 7.5) to preserve heat inside the cylinder during the winter months. The compost is discharged at the cylinder's extremity through an opening that also serves as an air inlet.<sup>1</sup> The rotation intervals and the amount of matter added regulate the amount of finished compost being discharged.

This composter is designed to work year-round, indoors or outdoors, and can compost a wide variety of O.W. In certain extreme conditions, adaptation may be required during the installation process.



Figure 1 -- Interior view of the cylinder

---

<sup>1</sup> Composters are pre-perforated to accommodate an optional ventilation system. Valves can also be installed as an option (passive ventilation).

## Safety

**Before operating this equipment, make sure that each employee understands and follows the safety, operation and maintenance rules described in this document.**

**No modifications should be made to this equipment without authorization from Brome Compost. Equipment modification will automatically invalidate the warranty offered by the manufacturer and could cause serious injuries.**

## Table of Content

INTRODUCTION .....	2
Section 1-- Safety .....	7
1.2 Operating the Equipment Safely .....	8
1.3 Performing Maintenance Safely .....	8
1.4 Precautions Against the Risk of Electrocution and Physical Damage.....	8
Section 2 – Important Information for Delivery.....	10
2.1 Transport and Unloading .....	11
Section 3 -- Installation .....	12
3.1 Site selection and preparation.....	12
3.2 Precautions for Outdoor Installation.....	12
3.3 Precautions for Indoor Installation .....	13
3.4 Electrical Installations.....	13
Section 4 – Operating Procedures.....	14
4.1 Sanitary Precautions When Composting .....	14
4.2 Verifying the Installation and Assembly Before Start-up.....	14
4.3 Initial Start-up.....	14
4.4 Monitoring the Temperature in the Composter.....	16
4.5 Odours .....	16
4.6 How to Set Rotation Intervals.....	17
4.7 How to Set the Door Position .....	18
Section 5 -- Maintenance.....	19
5.1 Performing Maintenance Safely (in Enclosed Spaces).....	19
Work Procedures for Enclosed Spaces .....	19
Securing the Composter and/or the Screw Feeder (Dispenser) .....	20
5.2 Checking the Condition of the Composter .....	20
5.3 Maintenance Schedule.....	21
Section 6 – Brome Composter Dimensions.....	22
Section 8 – Problem Solving.....	25

8.1 Broken Chain ..... 25

Section 9 – Warranty..... 26

9.1 Limitation of Liability ..... 27

## Section 1-- Safety

### 1.1 Safety instructions

- Never go into the cylinder unless you are trained to work in confined spaces and have authorization from your immediate superior; always follow the appropriate lockout procedure;
- Make sure all the warning labels are in place and visible
- Repairs and maintenance on the equipment must be made by qualified personnel only;
- Respect all established safety standards while performing maintenance on the equipment;
- Make a visual inspection of the equipment as often as possible
- It is recommended to use replacement parts from the manufacturer
- It is recommended to restrict access to the equipment by installing a fence or other barrier
- We recommend that the doors be locked when there is no surveillance or operator present



## 1.2 *Operating the Equipment Safely*

Before operating the composter, please note that a support service is offered for the installation, the initial start-up, and the training of personnel designated for the equipment's operation and maintenance.

Start-up support is available once the installation is completed. A remote monitoring service, as well as an interactive data tracking system are available upon request. Please contact Brome Compost for more information on this subject.

## 1.3 *Performing Maintenance Safely*

- Always ensure that the electrical current is switched off and that the lockout procedure is done properly when performing maintenance on the composter. If you must go inside the composter, be sure to have adequate ventilation and to respect the regulations governing work in enclosed spaces.
- If you need to rotate the cylinder during maintenance, please remove toolboxes, stepping stools, ladders, etc. and ensure that there are absolutely NO OBSTACLES within the rotational axis in front, in back, and on each side of the composter.

## 1.4 *Precautions Against the Risk of Electrocutation and Physical Damage*

- Always cut the electrical current if you need to open the control panel
- Never go beneath the composter
- Always ensure the doors are closed and locked before operating the composter
- Pay close attention to the turning of the wheels
- Never climb on the composter
- **Screw option : never clear or clean matter without first cutting the electrical current and locking the composter.**

## **Feeder Mechanism : Feeding Screw**

***Never place hands or tools inside the composter's feed shaft without first cutting the electrical current and always respect the recommended lockout and safety procedures.***

***If the screw mechanism becomes jammed, you should under no circumstances try to remove matter with your hands or with a tool without first having followed the safety lockout procedure.***

- 1) Operate the screw for only a few seconds in reverse to unblock it. Stop the screw and start it again in the right direction
- 2) If this does not work, follow the lockout procedure;
- 3) Remove the screw or the lock from the access door and remove the blocked matter carefully with an appropriate tool in order to avoid injuries;
- 4) Once the matter is removed, close the access door, put the screw or lock back in its proper position and restart the composter and the screw according to the proper procedure;



## Section 2 – Important Information for Delivery

Composter Model	Weight (empty) (Kg)	Weight (in operation) (kg)	Working Volume (m3)
Brome 406	599	1291	1.8
Brome 410	1796	2950	2.3
Brome 416	2199	4041	3.7
Brome 424	2595	5364	5.4
Brome 430	3193	6656	6.9
Brome 506	3492	4443	1.9
Brome 510	2023	3609	3.1
Brome 516	2381	4918	5.0
Brome 524	2821	3201	7.5
Brome 530	3401	8159	9.5
Brome 608	798	3113	4.6
Brome 616	3493	8121	9.2
Brome 624	5189	12132	13.8
Brome 630	5988	15245	18.3

## 2.1 Transport and Unloading

- Transport of the composter from the manufacturer to the installation site is the responsibility of the client.
- The unloading, on-site transport and installation of the composter are the responsibility of the client. The client is responsible for providing the machinery needed to unload the composter and a foundation on which to place it according to the technical data sheet provided by *Brome Compost*.



Place the strap firmly around the grooves by passing through the composter's support beams



Lift the composter with the appropriate lifting equipment (ensure that the composter is empty first).

## **Section 3 -- Installation**

### **3.1 Site selection and preparation**

The client is responsible for choosing the layout for the composting site and providing the correct type of surface required for the equipment, as specified in the information provided by Brome Compost. The composter must be installed on a level surface. The surface or structure must be strong enough to support the composter with its full load and ensure it stays level at all times. For example, a concrete slab or steel plate can serve as a foundation depending on the type of soil underneath it.



When the composter is used with mechanized loading equipment (e.g. a bin lift), we recommend securing the composter to the ground with an appropriate anchor depending on the type of surface it is resting on.

Respect all current regulations regarding the installation of a composting site.

### **3.2 Precautions for Outdoor Installation**

- Install the composter as far from houses as possible;
- Avoid placing the composter near an air intake, a ventilation system, windows and doors;
- Avoid placing the composter in busy areas;
- Unless the composter is equipped with a cover (available as an option), we recommend the installation of a fence around the equipment.

### 3.3 Precautions for Indoor Installation

- Plan a ventilation shaft or a sanitary drain that exits the building for the elimination of composting gas and odours;
- Do not place the air exit near an air intake, a door or a window;
- Take care to place the system in a separate room to avoid any contact with human food preparation or food storage areas in order to minimize contamination risks;
- Make sure the building's foundation can support the weight of the composter when it's both empty and full;
- Allow sufficient space around the composter to ensure ease of movement related to composting operations (addition of matter, collecting compost at the exit, etc.).

### 3.4 Electrical Installations

- The client is responsible for the electrical installations for the equipment.
- It is possible, however, to deliver the equipment with an electrical connection as specified by the client.
- Please contact Brome Compost to schedule your electrical installation before the delivery of the equipment.

## Section 4 – Operating Procedures

### 4.1 Sanitary Precautions When Composting

Composting is considered a safe activity for operators and compost users when certain basic rules are respected and followed. It is the owner's duty to give all necessary information to operators to ensure composting activities are conducted safely. Brome Compost is a manufacturer and is not responsible for the client's use of the equipment.

### 4.2 Verifying the Installation and Assembly Before Start-up

Verify that the surrounding area is free of all equipment, tools, etc. and that the safety guards are installed before the initial start-up.

### 4.3 Initial Start-up

#### **Before adding matter:**

- 1- Ensure that the emergency stop button is in the OFF position;
- 2- Wear personal safety equipment such as a mask, safety goggles, gloves;
- 3- Ensure that the doors are open facing the operator
- 4- If necessary, use a platform to ensure a safe and ergonomic operation
- 5- Verify that the composter is free from all possible collisions with equipment or work tools when it is rotating.

**Always make sure the emergency stop button is pulled (composter is working) after each use.**



Figure 2 -- Brome Composter Control Panel

## Adding Matter into the Composter

### Step 1:

Push the emergency stop button before working on the composter. This will prevent the rotation of the composter while you are working around the machine and when the door is open.

**Step 2:** Open the composter door.

#### Sliding door:

Unlock the door padlocks (on both handles) if you have this option. Pull the door locks at the same time as you pull on the handles. Pull on both handles alternately for ease of opening. When the handles are completely free, slide the door to the right.



#### Out-swing doors:

Unlock the door padlock (on the handle) if you have this option. Pull the handle slightly up and then towards you. Open both doors by pulling them towards you.



**Step 3:** Closing the door and starting the composter.

Close the door and lock the padlocks, if you have this option.

Start the composter by pulling the emergency stop button. A green light on the control panel will indicate that the composter is in operation.



### **Check the Organic Matter Before Adding It Into the Composter:**

Before adding organic matter to the composter, check the contents to be sure there is no foreign or contaminating matter (i.e. plastic, metal, glass, etc.). If you see foreign material, take out as much of it as you can before you add the bin contents into the composter.

**\*\* If you notice that most of the contents of the bin have a bad smell, throw it out.  
\*\***

## 4.4 Monitoring the Temperature in the Composter

Temperature is the best indicator of the composting process and it is crucial to monitor it daily. The best temperature range for aerobic composting is between 45°C and 70°C<sup>2</sup>.

- To read the temperature, check the thermometer(s) on the cylinder.

Using a portable thermometer is recommended for taking temperature readings at various locations through the door opening, especially during the initial start-up phase.



Figure 3 -- Composter Thermometer

## 4.5 Odours

Odour control is important to maintaining a good image of your composting installation and to avoid disagreements with your neighbours. By following good maintenance habits, you will prevent odour problems.

A good maintenance plan consists of:

1. Sweeping the floor and cleaning up splotches of O.W. on and around the composter;
2. Removing any waste that has fallen on the floor;
3. Carefully monitoring the composting process (make regular logbook entries, respect the procedures and recipes, etc.);<sup>3</sup>
4. Install an odour dispersion or treatment system if there is a possibility that odours may eventually bother neighbours in close proximity to your installation (available as an option).

---

<sup>2</sup> Check the standards in effect.

<sup>3</sup> An online calculator for composting recipes and monitoring is available as an option.

## 4.6 How to Set Rotation Intervals

The Brome composter can be set to rotate at different intervals by adjusting the programmable timer located in the control panel.

### 1. Locate the timer on the control panel:

- The clock can be set for different units of time (hours, seconds and minutes) to meet the needs of the user;
- Turn the screw located at the lower left on the clock (see red circle on the photo) to change the time intervals;
- Turn the screw located at the top right on the clock (see the red circle on the photo) to change the time units (hours, minutes).



Figure 4-- Rotation Programmed Every Hour

### 2. Turn the plastic wheel to change the hand position.

During normal use, the composter's rotation intervals should be around an hour. During special operations, it can be programmed differently.

### 3. When you are finished setting the adjustments, close the panel.

## 4.7 How to Set the Door Position

The rotations can be stopped at a specific spot so that the door's position is always the same.

1. Press the red emergency stop button on the composter before you work on or near it.
2. Unscrew the panel located to the side of the control box.

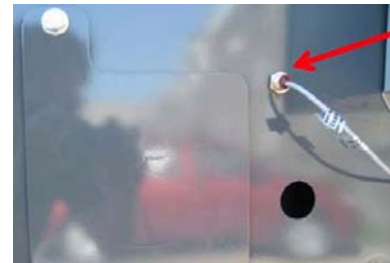

3. When you look inside the composter, on the right-hand side, you will see a red magnet. The magnet stops the composter after a full rotation when it passes in front of the sensor. Remove the magnet and put it aside.



4. Pull the emergency stop button and set the composter on manual mode. Turn the composter to set the door at the desired position. Push the emergency stop button.

5. Put the magnet in front of the sensor. Pull the emergency stop button and allow one rotation on automatic mode to test the door stop position (set the clock at 0 to make a rotation on automatic mode).



6. After one rotation, the door should stop at the same position from which it started (if you still hear the alarm, put the composter back on manual mode to prevent a second rotation).

7. If the position is correct, you can screw the panel back on, set the clock back to its original position and return the composter to automatic mode.

## Section 5 -- Maintenance

### 5.1 Performing Maintenance Safely (in Enclosed Spaces)

#### Work Procedures for Enclosed Spaces

Never enter the cylinder without having the proper training for work in closed spaces and without your organisation's authorisation. Always use the appropriate lockout procedure.

Generally speaking, an enclosed space refers to a partially or completely closed site that:

- Is not adapted nor destined for prolonged human occupation
- Has limited or restricted access and exit routes, or has a configuration that complicates first aid, rescue and evacuation procedures, as well as other emergency intervention practices
- Presents a potential risk to the health and security of persons entering the space, due to one or more of the following factors:
  - Its conception, its construction, its location and its atmosphere
  - The matter or substances that it contains
  - The nature of the work to be done
  - Risks related to the mechanisms and procedures used, as well as dangers to personal security

Please visit the following Government of Canada website for more information on enclosed spaces:

[https://www.cchst.ca/oshanswers/hsprograms/confinedspace\\_intro.html](https://www.cchst.ca/oshanswers/hsprograms/confinedspace_intro.html)

## Securing the Composter and/or the Screw Feeder (Dispenser)

For your safety, it is vital to lock the composter in position during all maintenance procedures, whether it be according to the established schedule or when a malfunction occurs.

### **Composter:**

It is important to cut contact and lock the control panel while performing your maintenance routine in order to prevent someone else from accidentally starting or turning the composter. If you are inside the composter, make sure that another person is there to monitor you or make sure that you clearly indicate your presence.

### **Feeding Screw (Dispenser):**

Never attempt to clean, unblock or perform maintenance on the feeding screw with your hands unless the power is cut and the screw is locked in position. Serious injuries could result. In addition, the lateral panel should always be blocked so that it cannot open when in operation.

## 5.2 Checking the Condition of the Composter

The Brome Composter is designed to function with only minimal maintenance. To ensure the composter's optimal operation, you must:

- Regularly inspect the inside of the cylinder to identify any damage that could cause premature deterioration. Remove the output end cap occasionally to allow an unobstructed inspection of the interior surfaces of the cylinder.
- Inspect and clean the area surrounding the cylinder. If material accumulates around the exterior, it can hinder the cylinder's rotational movements, contribute to the development of fly larvae, attract animals and create odours.
- Regularly inspect the opening through which the finished compost exits the cylinder (exit outlet) and clean it, if necessary.
- Do not operate the composter during prolonged periods of inactivity during the wintertime (in freezing conditions), and when if the material inside is frozen. This could damage the equipment.

### 5.3 Maintenance Schedule

Component		Check	Frequency
<b>1</b>	Door	Rubber Seal	Weekly
	Door	Easy to open	Each use
<b>3</b>	Compost exit outlet	Compost height	Each use
<b>4</b>	Ventilation	Working well	Weekly
<b>5</b>	Composter level	Keep it leveled	Twice a year
<b>6</b>	Control panel	➤ Waterproof	Monthly
		➤ Broken buttons	
<b>7</b>	Sifter	Holes are free of waste	Weekly
<b>8</b>	Interior of composter	Visual inspection	Annually
<b>9</b>	Mechanical components (motor, gear box, panel)	See manufacturer recommendations	As recommended
<b>10</b>	Wheel (Rotating and guide wheels)	➤ Visual inspection	Each use
		➤ Rolling smoothy	
		➤ Check bearings	

## Section 6 – Brome Composter Dimensions

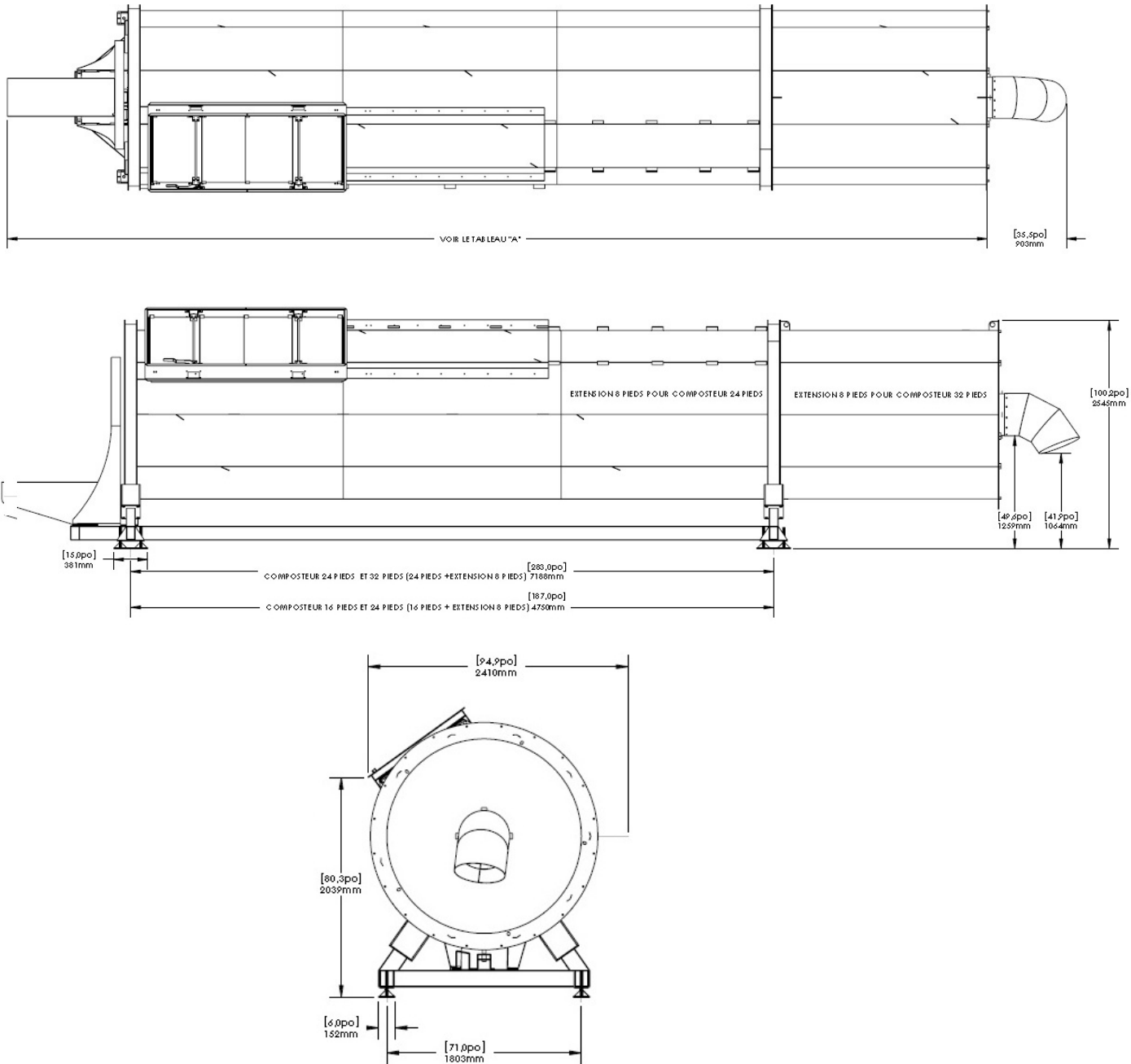

## 7 Equipment options / accessories

*Brome Compost* offers a wide range of accessories to facilitate on-site composting. Contact us for more information or if you have questions regarding the different options we offer.



Loading Ramp



Dumping Bin

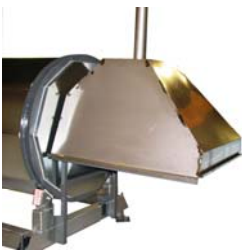

Ventilation option (With full air extraction)



Valve for passive ventilation



Universal Bin Lifter



Protected safety cage

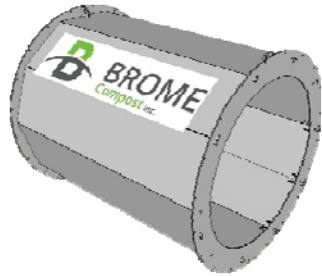

Extension



Sifter



Out-swinging doors



Sliding door



Stainless steel finish

For more information, contact: Brome Compost

**450 574-2000**

Always inform your immediate superior of any incidents and/or damage to the equipment.

## Section 8 – Problem Solving

### ***8.1 Broken Chain***

- Are the four wheels in good working condition? Perform a visual inspection of the rotating and guide wheels, and their bearings. A visual inspection should suffice.
- Are the two guide wheels located under the front part of the composter in good condition? Are they misaligned or rubbing against the groove thread?
- Is the composter rotating well on all four wheels when in operation?
- Is the composter level? 50%, 60%, 70% or more?
- Is the chain tensioner in good working condition? This prevents the chain from jumping off the sprocket.
- Are the two groove threads allowing the four wheels to turn correctly or are they problematic?
- Are the motor sprocket, the chain tensioner and the large composter sprocket all aligned?
- What is the internal temperature of the cylinder?
- According to you, are the humidity levels of the matter in the cylinder high, low or normal?
- To what height is the composter filled?
- Is the composter turning clock-wise when you look at the cylinder from the head / motor end?
- Is the overload mode on the control panel activated and causing the composter to restart?
- Could some material have become stuck in the chain or sprocket and damage either one?
- Are all the sprockets correctly aligned?

## Section 9 – Warranty

The Brome Composter is guaranteed against manufacturing defects for one (1) year after the invoicing date. The warranty includes reimbursement, replacement, correction and/or the repairing of the defect. Brome Compost will repair or replace equipment that displays a defect during normal usage at our discretion. This warranty covers parts and labour.

Mechanical parts (the control panel and the motor/gear box) are guaranteed against manufacturing defects, according to the current guarantees of the supplier of these parts. This guarantee includes replacement, correction and/or the repairing of the defect. It covers parts and labour.

In case of damage, the supplier's/manufacturer's corroboration and assessment will aid in determining the decision to repair or replace a defective part.

All travel and/or delivery expenses, brokerage and customs fees are at the expense of the client.

Any damage due to environmental conditions are not covered by the warranty for the modular composter and its mechanical parts.

Any modification to the modular composter and its components made by a third party not authorised by Brome Compost will result in the automatic cancellation of the warranty.

<b>Components</b>	<b>Warranty</b>	<b>Conditions</b>	<b>Duration</b>
Modular Composter	Manufacturing defaults	Replacement, correction and/or repairing of the defect.	1 year after the invoicing date
Mechanical Parts	According to the manufacturer	Replacement, correction and/or repairing of the defect.	According to the manufacturer

Brome Compost rejects all other damages sought due to defects or breakage of its equipment such as profit loss, travel, transport and labour costs.

Only this warranty applies to Brome Compost's equipment. No other person is authorised to interpret this warranty.

Operating the composter when the condition of the organic matter is such that it has a higher than 63% humidity level may result in mechanical and/or operating problems, as well as a premature deterioration of the system, which may limit the warranty.

### **9.1 Limitation of Liability**

Please note that *Brome Compost inc.* is not responsible for problems that may present themselves due to the nature of the biological process involved in composting activities and releases itself from all such liability. We cannot guarantee that no problems will arise during the operation of the composter, as this is contingent upon the nature and variety of the organic matter to be processed, the operator's experience as well as the influence of weather conditions.

The equipment is under guarantee for normal use. A mechanical breakdown or premature wear of the equipment caused by abusive use will invalidate the manufacturer's warranty.

*Brome Compost inc.* reserves the right to make changes to the conception and manufacturing of their line of equipment at any time without obligation to change or modify the products already sold.