



# **AGNICO EAGLE**

**MELIADINE GOLD MINE**

## **Water Management Plan**

---

**JUNE 2026  
VERSION 19  
6513-MPS-11**

## EXECUTIVE SUMMARY

---

Agnico Eagle Mines Limited (Agnico Eagle) is operating the Meliadine Gold Mine (Meliadine Mine), located approximately 25 kilometres (km) north of Rankin Inlet, and 80 km southwest of Chesterfield Inlet in the Kivalliq Region of Nunavut.

The water management objectives are to minimize potential impacts to the quantity and quality of surface water at the Mine. Water management structures include collection ponds (CPs), saline ponds (SPs), mined-out pits, diversion channels, dikes, berms, and treatment facilities: a potable Water Treatment Plant (WTP), a Sewage Treatment Plant (STP), an Effluent Water Treatment Plant (EWTP), a Saline Effluent Treatment Plant (SETP), and a Saline Effluent Waterline.

During mine Construction and Operations, water originating from affected areas on surface will be intercepted, diverted and collected within designated collection ponds. The collected contact water at the Mine will eventually be pumped and stored in Collection Pond 1 (CP1) and in Wesmeg Open Pit 3 (WES03), once mining of this pit is complete. Water stored in CP1 will be treated by the EWTP for removal of Total Suspended Solids (TSS) prior to discharge to the receiving environment. WES03 serves as an intermediate storage reservoir for contact water prior to controlled discharge to Itivia Harbour. Discharge to Itivia Harbour is prioritized, with the remainder discharged to Meliadine Lake according to the approved Meliadine Mine Adaptive Management Plan. At the Discovery site, contact water will be managed in the Discovery collection ponds (CPD1 and CPD2) and subsequently conveyed to the mined-out Wesmeg Open Pit 2 (WES02) for discharge to Itivia Harbour. Contact water from the Underground Mine will be collected in underground storage stopes and sumps. Some water from Underground will be reused for underground operations. Excess saline contact water will be pumped to SPs on the surface. From there, it is transferred to Tiriganiaq Open Pit 02 (TIRI02) or WES02, and ultimately treated at the SETP-WTC prior to discharge to Itivia Harbour via the waterline.

The long-term, post-closure water quality in the collection ponds and in the flooded open pit lakes will meet Metal and Diamond Mining Effluent Regulations (MDMER), Canadian Council of Ministers of the Environment Water Quality Guidelines (CCME-WQG) for the protection of aquatic life and/or the Site-Specific Water Quality Objectives (SSWQOs) developed for the Mine.

During mine closure, the water management infrastructure on site will remain in place until mine closure activities are completed, and monitoring demonstrates that the water quality is acceptable for environmental discharge without treatment.



## TABLE OF CONTENTS

---

<b>EXECUTIVE SUMMARY</b> .....	<b>i</b>
<b>ᑭᐱᑦ ᑭᐱᑦᑭᐱᑦ</b> .....	<b>ii</b>
<b>TABLE OF CONTENTS</b> .....	<b>iii</b>
<b>LIST OF FIGURES</b> .....	<b>vi</b>
<b>LIST OF TABLES</b> .....	<b>vi</b>
<b>DOCUMENT CONTROL</b> .....	<b>viii</b>
<b>ACRONYMS</b> .....	<b>xiii</b>
<b>UNITS</b> .....	<b>xiv</b>
<b>SECTION 1 • INTRODUCTION</b> .....	<b>1</b>
1.1 Water Management Objectives .....	1
1.2 Management and Execution of the Water Management Plan .....	1
<b>SECTION 2 • BACKGROUND</b> .....	<b>2</b>
2.1 Site Conditions .....	2
2.1.1 Local Hydrology .....	2
2.1.2 Ice and Winter Flows .....	2
2.1.3 Spring Melt (freshet) and Freeze-up Conditions .....	3
2.1.4 Permafrost .....	3
2.1.5 Local Hydrogeology .....	3
2.2 Mine Development Plan .....	3
<b>SECTION 3 • WATER MANAGEMENT CONTROLS AND STRUCTURES</b> .....	<b>5</b>
3.1 Water Management Systems .....	5
3.2 Water Management Structures Design Criteria .....	9
3.3 Water Collection ponds .....	11
3.4 P-Area Ponds .....	12
3.5 Contaminated Snow Cell .....	12
3.6 Saline Ponds .....	13

3.6.1	Existing Saline Ponds.....	13
3.6.2	CP7 (Lake B7) to be Constructed.....	14
3.7	Water Storage in Mined-Out Pits.....	14
3.8	Water Diversion Channels, Dikes and Berms.....	14
3.8.1	Water Diversion Channels.....	14
3.8.2	Water Retention Dikes and Berms.....	15
3.8.2.1	Thermal Monitoring.....	16
3.9	Freshwater Intake.....	17
3.10	Water Treatment.....	17
3.10.1	Freshwater Treatment Plant (WTP).....	17
3.10.2	Sewage Treatment Plant (STP).....	17
3.10.3	Saline Water Treatment Plant (SWTP).....	17
3.10.4	Water Treatment Complex (WTC).....	18
3.10.4.1	Effluent Water Treatment Plant (EWTP).....	18
3.10.4.2	Saline Effluent Treatment Plant (SETP).....	19
3.10.4.3	Sludge management.....	19
3.10.5	Oil-Water Separators.....	19
3.10.6	Reverse Osmosis Plant (RO).....	20
3.11	Meliadine Lake Discharge Diffuser.....	21
3.12	Saline Water Discharge to Sea.....	21
3.13	Water Management Structure Monitoring.....	21
3.13.1	Culvert and Water Crossing Inspections.....	21
3.13.2	Collection Pond Inspections.....	22
3.13.3	Dike and Thermal Berm Inspections.....	22
3.13.4	Water Diversion Channel and Berm Inspections.....	22
<b>SECTION 4 • WATER MANAGEMENT STRATEGY.....</b>		<b>23</b>
4.1	Key Water Management Activities.....	24
4.1.1	Pond Dewatering and Displacement.....	28
4.1.2	Underground Water Management.....	31
4.1.3	Water Management for Haul Road.....	31
4.1.4	Water Management for Landfarm and Landfill.....	31

4.1.5	Water Management for Emulsion Plant Area.....	32
4.1.6	Water Management for the Wash Bay.....	32
4.2	Freshwater and Sewage Management .....	32
4.2.1	Freshwater Management.....	32
4.2.2	Sewage Management.....	33
4.2.3	Process Water Management.....	33
4.3	Meliadine Lake Diffuser Effluent Flow Rates.....	34
<b>SECTION 5 • WATER BALANCE.....</b>		<b>35</b>
5.1	Site Water Balance Model.....	35
5.2	Model Setup .....	36
5.3	Water Management Assumptions and Inputs .....	36
5.3.1	Pond Pumping Rates .....	36
5.3.2	Discharge to Itivia Harbour .....	37
5.3.3	Discharge to Meliadine Lake .....	37
5.3.4	Underground Mine Dewatering.....	37
5.3.5	Consumptive Freshwater Uses .....	38
5.3.6	Sewage Treatment Plant Discharge .....	38
5.3.7	Climate Inputs .....	38
5.3.8	Waterbodies Dewatering .....	39
5.3.9	Water Quality Model Component .....	39
5.4	Water Balance Model Methods.....	40
5.4.1	Approach and Assumptions .....	40
5.4.2	Sub-Catchment Delineation.....	40
5.4.3	Watershed Model.....	40
5.4.4	Potential Evapotranspiration .....	41
5.4.5	Lake Ice Growth and Ice Melt .....	41
5.4.6	Closure and Post-Closure Assumptions .....	41
5.5	Waterbody Inventory .....	42
<b>SECTION 6 • WATER QUALITY .....</b>		<b>44</b>
6.1	Summary of Regulatory Guidelines .....	44
6.2	Water Quality Monitoring - Licence Amendment.....	45

6.3	Water Quality Modelling and Forecasts.....	45
6.4	Post-Closure .....	45
<b>SECTION 7 • WATER MANAGEMENT DURING CLOSURE.....</b>		<b>46</b>
7.1	Mine Flooding.....	46
7.3	Collection Ponds, Dikes and Berms .....	47
7.4	Channels and Sumps.....	47
<b>REFERENCES .....</b>		<b>48</b>
<b>FIGURES.....</b>		<b>53</b>

## LIST OF FIGURES

Figure 1:	General Mine Site Location Plan.....	53
Figure 2:	General Mine Site Plan Layout .....	54
Figure 3:	P-Area Plan View and Design of the P3 Pad.....	55
Figure 4:	Location and Design of Saline Pond 4 (SP4) within Tiriganiaq Pit 1.....	56
Figure 5:	Mine Site Layout at 2036.....	57
Figure 6:	Conceptual Site Water Management Flow Diagram for the Site.....	58
Figure 7:	Conceptual Site Water Management Flow Diagram as Planned at the End of the Life of Mine... 59	
Figure 8:	Water Quality Monitoring Locations on Site .....	60
Figure 9:	Water Quality Monitoring Locations at Itivia .....	61
Figure 10:	Mine Site Layout After Closure.....	62
Figure 11:	Simplified Diagram of the EWTP-WTC and SETP-WTC Feed and Discharge Points .....	65

## LIST OF TABLES

Table 1:	Constructed Water Management Control Structures.....	7
Table 2:	Water Management Control Structures to be Constructed .....	8
Table 3:	As-Built Parameters for CP1 and CP5.....	10
Table 4:	As-Built Parameters for CP2, CP3, CP4, and CP6.....	11
Table 5:	Location of Collection Pond and Required Operation Periods.....	11
Table 6:	P3 Sump Design Criteria .....	12
Table 7:	Storage Capacities for Saline Pond 1 (SP1) and Tiriganiaq Pit 2 (TIRI02).....	14
Table 8:	As-Built and Design Parameters for Channels .....	15
Table 9:	As-Built and Design Parameters for Water Retention Dike/Berm .....	16
Table 10:	Existing Water Management Infrastructures.....	23
Table 11:	Water Management Infrastructures to be Constructed .....	24
Table 12:	Completed and Planned Key Water Management Activities.....	25
Table 13:	Planned Lakes and Ponds Dewatering Schedule Inventory .....	30
Table 14:	Freshwater Consumption for Meliadine Mine.....	33

Table 15: Evolution of Site Water Balance Model ..... 35  
Table 16: Average monthly climate conditions at Meliadine for the Operations Phase..... 38

**APPENDICES**

**APPENDIX A**

Waterline Operation and Maintenance

**DOCUMENT CONTROL**

Version	Date	Section	Page	Revision	Author
6	March 2019	All	All	Update is to fulfill annual review requirement (NWB)	Environment Department
		1	4	Update to Mine Development Plan information	
		3.1	8-12	Updated Version 6 changes	
		3.2	11-12	Updated existing water management control structures	
		3.3	12-14	Revised structure design semantics; corrections to culvert design; updated CP3, CP4 design parameters and naming convention; removed incorrect artifact pertaining to culvert 1 flow handling	
		3.6	15		
		3.8	17-21	Addition of SP3; updates to SP2 design Included as-built parameter values; updated berm and dike naming convention, thermistor information Updated freshwater intake design information; updates to SWTP system; RO management; EWTP monitoring; removed incorrect information pertaining to Freshwater intake Updated management of saline discharge to sea; revised information proposed in initial design	
		3.9	21-22		
3.11	25-31				
4.1	25-31				
4.2					
4.6	35	Updated key management activities schedule to include discharge to sea; updated regarding underground inflow management; revised haul road management; revised wash bay management; updated process water quantities			
6.3	37				
7	40				
		Figure 1.2 Figures 6.1, 6.2		Updated impacted waterbodies status Revised semantics regarding flow paths	
		Figure 7.1a 3.9.4		Included additional information regarding July 23rd exceedance Updated Layout to most recent General Mine Site Plan Specified plan layouts are from feasibility level study	
7	August 2019	4.1	20	Updated Layout with monitoring stations to most recent General Mine Site Plan	Environment Department
		4.1.1	26		
		3.5	27-28		
8	November 2019	Figure 3.2		Updated EWTP trigger limit to account for variance introduced by TSS- turbidity correlation strength	Environment Department
9	March 2020	Exec. Summary		Updated EWTP trigger limit to account for variance introduced by TSS- turbidity correlation strength Updated Key Activities (Table 10) to reflect changes to H19/H20 dewatering schedule Revised H19/H20 dewatering plan with requirements for advancement in dewatering schedule; Updated dewatering schedule (Table 11)	Environment Department
		3.1			
		3.2			
		3.3			

Version	Date	Section	Page	Revision	Author
		3.4 3.5 3.6 3.9  3.11 3.12 4.1 4.2 4.3  5 7  Figure 1.1 Figure 1.2		Updated Saline Pond section to include current existence of SP2 and plans for construction of SP4. Figure changed from planned location of SP2 to planned location of SP4. Update is to fulfill annual review requirement (NWB) Updated to include SETP, excess saline contact water management Updated existing water management systems (saline ponds, SETP, discharge to sea) Updated Table 2 and Table 3 Updated to include CP4 as existing structure and modified CP6 construction date Update to Section Updated to Section Updated Table 7 Update to SWTP and EWTP systems, addition of SETP Updated management of saline water discharge to sea Update to Section Updated Table 10 and Section Updated process water management Updated Meliadine Lake diffuser effluent flow rates and EWTP sludge disposal options Update to Section Update to Section. Removed information already presented in annual report (i.e., MEL-14 and MEL-SR results). Updated Layout to most recent General Mine Site Location Plan Updated Layout to most recent	
10	July 2021	All 3 3.1 3.2 3.3 3.5 3.6 3.9.4 4 4.3 5 6 7 Figure 2 Figure 4 Figure 6 Figure 8 Figure 9		Updated to support Water Licence Amendment Updated to include CP2, CP2-Berm, Channel 9 and 10, and decommissioning of SP2 Updated Table 1 and section Updated Table 3 and section Updated Table 4 and section Removed SP2 and updated Table 6 and section Updated Table 7 and 8 and section Update to EWTP system Updated to add CP2 and update Table 9 and 10 Update EWTP discharge rate and Table 13 Water Balance update, moved section of Water Balance results and table into appendix C Water Quality update ICRP 2020 update and Table 16 to include CP2 Updated layout to most recent General Mine Site Updated following decommissioning of SP2 Updated to include CP2 monitoring	Environment Department

Version	Date	Section	Page	Revision	Author
				Updated layout to most recent General Mine Site during closure Updated layout to most recent General Mine Site after closure	
11	August 2021	All	All	Updated as per Part B, Item 13 of the Amended Water Licence	Environment Department
		2.2	8-9	Updated section to reflect current Mine Plan	
		3	10	Added terminology and definitions for Plan clarity, removed Evaporators subsection	
		3.1	10	Removed SWTP from water management systems, updated Table 1	
		3.4	15-16	Updated section and Table 5 to reflect P-Area decommissioning	
		3.5	16	Added section on Contaminated Snow Cell	
		3.6	16-17	Updated section and Table 6 to include Tiriganiaq Pit 2 as saline water storage	
		3.9.3	20-21	Updated section to reflect current SWTP status	
		3.9.4	21	Section reorganized to include EWTP and SETP in Water Treatment Complex (WTC)	
		3.9.4.3	22	Added section to discuss current and possible future sludge management options	
		3.9.5	22	Updated to include second oil water separator at the maintenance shop wash bay	
		4	26	Updated section and Table 9 to include Tiriganiaq Pits 1 and 2 in Water Management Strategy items	
		4.1	28-30	Updated section and Table 10	
		4.3	35	Updated section and Table 13	
		5 & 6	35, 37	Updated sections, removed WB and WQ results from document (these are/will be provided in Annual Reports)	
12	April 2022	3.9.6		Added RO Treatment Section	Environment Department
13	April 2023	2.1.5	8	Minor changes to the local hydrology section text	Environment Department
		3.1	10-12	Addition of channel 2 berm planned in Q2 2023	
		3.2	14	Modification of as-built numbers Text update on section P-area containment ponds	
		3.4	15-16	Addition of description on SP3 saline pond	
		3.6	16-17	Update of as-built numbers for channels 9 and 10, addition of channel 2 berm	
		3.7	18	Management activities accomplished in 2022 and planned for 2023 Modification of predicted Groundwater inflows for version V14 of the Golder model	
		4.1	30	Update of Effluent discharge numbers for 2022	
		4.1.2	32		
4.3	38				
14_NWB	January 2024	Throughout	Throughout	Submitted to Nunavut Water Board as part of the Meliadine Mine Water Licence Amendment	Permitting Department

Version	Date	Section	Page	Revision	Author
14.1_NWB	February 2024	4.3		Submitted to Nunavut Water Board Errata	Environment Department
15	February 2025	1, 2.2, 3.6.1, 3.6.2, 3.7.1, 3.7.2, 3.9.4.1-3.9.4.3, 4.1, 4.1.4, 4.3		Text edits	Environment Department
		Table 1	11	Table modification according to schedule updates	
		3.1	13-14	Additions of water management system components and text edits	
		Table 2	16	Addition of Channel 2 berm	
		Table 3	16-17	Addition of containment ponds, Berm 4, removal of channels 12-13	
		3.2	18-19	Addition of detail on design criteria for new water management infrastructure and text edits	
		Table 6	20	Addition of CP9	
		3.4	20	Detail on modification of P3 area	
		Table 7	21	Inclusion of detail on P3 sump design criteria	
		Table 9	25	Addition of channel 11	
		Table 10	26	Addition of Channel 2 berm and Berm 4	
		Table 12	36	Removal of SUMP P1, P2 and P5	
		Table 13	37-38	Addition of planned infrastructure and merge of previous version's Table 14	
		4.1.1	41	Inclusion of details on pond dewatering	
		4.2.1	46	Volume updates	
		Table 14		Addition of a table detailing planned pond dewatering information	
		Table 15		Inclusion of latest updated groundwater model results	
Section 5	50-60	Addition of details on water balance modelling			
Appendices		Removed Appendices. These will be submitted as standalone documents moving forward.			
15b	March 2025	3.9.4.2, 3.9.4.3, 5.3.7, Table 16		Updated to reflect Agnico Eagle is currently designing a treatment system for ammonia nitrogen to meet the MDMER which will replace breakpoint chlorination	Environment Department
16	June 2025	1.1	9	Updated for Meliadine Pump Underground and Water Storage in Pits Modification	Permitting Department
		2.2	13		
		3	All		
		4	All		
		5	All		
		6.3, 6.4	53		
		7.1	54		

Version	Date	Section	Page	Revision	Author
17	March 2026	1, 2, 3.2, 3.5, 3.6.1, 3.8, 3.10.2, 3.10.4, 3.10.4.3, 3.10.5, 3.10.6, 4.1.2, 4.1.3, 4.1.4	1, 2, 11, 14, 14, 16, 19, 20, 21, 22, 36, 36, 36	General text edits	Environment Department
		3.1	6	General update of water management systems according to Mine Plan and text edits	
		3.3	13	Modification of Table 5 to include CP7 and CP9/Pump01	
		3.7	15	Change of label SP6 to CP7. More details of water management in mined-out pits	
		3.8.1	16	Correction of construction timeline of Channel 11	
		3.8.2	17	Text edit in Table 8	
		3.8.2.1	18	Text edit in Table 9	
		3.10.3	19	Text edits and precision on SWTP decommissioning	
		3.10.4.2	21	Clarification of SETP treatment	
		3.12	23	Text edits and Saline Water Storage in TIRI02 timeline clarification	
		4	27	General update of Table 10 and Table 11 according to Mine Plan and text edits	
		4.1	29	Modification of Table 12 to clarify planned schedule infrastructure and text edits	
		4.1.1	33	Lake dewatering general update and text edits	
		5	40-49	Complete update of Section 5 by Lorax	
		7.1	52	Clarification on active closure mine flooding strategy	
References	57	Formatting of references and addition of WSP Underground inflow Predictions 2026 update			
Figures	59-64	General update of Figure 2 according to Mine Plan. Update of Figure 5, Figure 6, and Figure 7 according to Lorax WBWQM latest model.			
18	April 2026	3.12 Appendix A	22	Addition of Appendix A – Waterline Operation and Maintenance	Environment Department
19	June 2026	1, 2.2, 5.3.4, 5.4.6, Table 18, Figures 5-7, 10	1, 3, 37, 41, 46	Changes made to support 2026 Operational Update – Water Licence Amendment, including Mine Plan updates	Permitting Department
		3.1	5	Update to mined-out pits for water storage	
		Table 5	11		
		4	23		
		Table 14	33	Update to freshwater use	
Table 15	35	Inclusion of updated water balance			
7.2	47				

## ACRONYMS

---

Agnico Eagle	Agnico Eagle Mines Limited
AWAR	All Weather Access Road
BTEX	Benzene, Toluene, Ethylbenzene and Xylene
CCME-WQG	Canadian Council of Ministers of the Environment Water Quality Guidelines
CIRNAC	Crown-Indigenous Relations and Northern Affairs Canada
CP	Collection Pond
ECCC	Environment and Climate Change Canada
EQC	Effluent Quality Conditions
EWTP	Effluent Water Treatment Plant
FDP	Final Discharge Point
FEIS	Final Environmental Impact Statement
GTC	Ground Temperature Cable
GWMP	Groundwater Management Plan
ICRP	Interim Closure and Reclamation Plan
IDF	Inflow Design Flood
Licence	Type A Water Licence 2AM-MEL1631
MDMER	Metal and Diamond Mining Effluent Regulations
NIRB	Nunavut Impact Review Board
NWB	Nunavut Water Board
Mine	Meliadine Gold Mine
OP	Ore Pad
RO	Reverse Osmosis
SD	Support Document
SETP	Saline Effluent Treatment Plant
SP	Saline Pond
SSWQO	Site Specific Water Quality Objective
STP	Sewage Treatment Plant
SWTP	Saline Water Treatment Plant
TDS	Total Dissolved Solids
TSF	Tailings Storage Facility
TSS	Total Suspended Solids
WMP	Water Management Plan
WQ-MOP	Water Quality Management and Optimization Plan
WRSF	Waste Rock Storage Facility
WTC	Water Treatment Complex
WTP	Water Treatment plant

## UNITS

---

%	percent
°C	degrees Celsius
°C/m	degrees Celsius per metre
mg/L	milligram per litre
km	kilometer(s)
km <sup>2</sup>	kilo square meter(s)
m	metre
mm	millimetre
m <sup>3</sup>	cubic metre(s)
m <sup>3</sup> /day	cubic metre per day
m <sup>3</sup> /s	cubic metre per second
m <sup>3</sup> /hour	cubic metre per hour
m <sup>3</sup> /year	cubic metre per year
Mm <sup>3</sup> /year	million cubic metre (s) per year
Mm <sup>3</sup>	million cubic metre(s)
masl	metres above sea level
Mt	million tonne(s)

## SECTION 1 • INTRODUCTION

Agnico Eagle Mines Limited (Agnico Eagle) operates the Meliadine Gold Mine (Meliadine Mine) located approximately 25 kilometres (km) north of Rankin Inlet (Figure 1), Nunavut, and 80 km southwest of Chesterfield Inlet in the Kivalliq Region of Nunavut. The Mine is subject to the terms and conditions of both the amended Project Certificate 006 issued by the Nunavut Impact Review Board (NIRB) in accordance with the Nunavut Land Claims Agreement Article 12.5.12 on March 2<sup>nd</sup>, 2022 (NIRB, 2022) and the Amended Water Licence No. 2AM-MEL1631 (the Licence), issued by the Nunavut Water Board (NWB) on October 25<sup>th</sup>, 2024 and approved by the Minister of Northern Affairs on November 22<sup>nd</sup>, 2024 (NWB, 2024). The previous Type A Water Licence (2AM-MEL1631) authorized the mining undertaking at Tiriganiaq open pits and underground. The recently amended Water Licence also includes mining of the Wesmeg/Wesmeg North, Pump, F Zone, and Discovery deposits that were included in the 2014 Final Environmental Impact Statement (Agnico Eagle 2014) and Project Certificate No.006. A Water Licence Modification Application was approved in 2025 for the following:

- Development of a portal within Pump Open Pit 2 (PUMP02) to facilitate access to mineralized zones within permafrost;
- Temporary surface storage of waste rock generated from Pump Underground development; and
- Utilization of mined-out pits for the storage of saline or contact water.

The 2026 Water Licence Amendment Operational Update further extends operations through 2036, including PUMP02 development below permafrost. This document presents the updated Water Management Plan (WMP) incorporating the most recent regulatory approvals and proposed modification activities.

### 1.1 Water Management Objectives

The water management objectives are to minimize potential impacts to the quantity and quality of surface water at the Mine and surrounding waterbodies. The purpose of the WMP is to provide information to applicable mine departments (e.g., Environment, Engineering, Mine, Energy and Infrastructure, etc.) for sound water management practices, proposed and existing infrastructure, the water balance model, water quality predictions, and for the water quality monitoring plan for the Mine.

Water management structures (collection ponds, mined-out open pits, culverts, sumps, pipelines, water diversion channels and water retention dikes/berms) are utilized to contain and manage contact water from areas affected by mining activities. Measures have been implemented for the Mine Construction and Mine Operation phases.

### 1.2 Management and Execution of the Water Management Plan

Revisions of the WMP can be initiated by changes in the Mine Development Plan (Mine Plan), operational performance, personnel or organizational structure, regulatory or social considerations, and/or design philosophy. The WMP will be reviewed annually by Agnico Eagle and updated as necessary as part of the Annual Report. The Meliadine Mine Adaptive Management Plan is also used in combination with the Water Management Plan to provide management and mitigation actions.

---

## SECTION 2 • BACKGROUND

---

### 2.1 Site Conditions

The Mine is located in an area of poorly drained lowlands near the northwest coast of Hudson Bay. The dominant terrain in the area consists of glacial landforms such as drumlins (glacial till), eskers (gravel and sand), and many small lakes. The topography is gently rolling with a mean elevation of 65 m above sea level (m asl) and a maximum relief of 20 m.

The local overburden consists of a thin layer of topsoil overlying silty gravelly sandy glacial till. Cobbles and boulders are present throughout the region at various depths. Bedrock at the Mine site area consists of a stratigraphic sequence of clastic sediments, oxide iron formation, siltstones, graphitic argillite, and mafic volcanic flows (Snowden, 2008; Golder, 2009).

The climate is extreme in the area, with long cold winters and short cool summers, and mean air temperatures of 12°C in July and -31°C in January. The mean annual air temperature at the Mine site is approximately -10.4 °C (Golder, 2012a). Strong winds blow from the north and north-northwest direction more than 30 percent of the time.

The mean annual precipitation in the area is approximately 412 mm and is typically equally split between rainfall and snowfall.

#### 2.1.1 Local Hydrology

The Mine is located within the Meliadine Lake watershed. Meliadine Lake has a water surface area of approximately 107 square kilometres (km<sup>2</sup>), a maximum length of 31 km, features a highly convoluted shoreline of 465 km, and has over 200 islands. Unlike most lakes, it has two outflows that drain into the Hudson Bay through two separate river systems. It has a drainage area of 560 km<sup>2</sup> upstream of its two outflows. Most drainage occurs via the Meliadine River, which originates at the southwest end of the lake. The Meliadine River flows for a total stream distance of 39 km through a series of waterbodies, until it reaches Little Meliadine Lake and then continues into the Hudson Bay. A second, smaller outflow from the northwest basin of Meliadine Lake drains into Peter Lake, which discharges into the Hudson Bay through the Diana River system (a stream distance of 70 km). At its mouth, the Diana River has a drainage area of 1,460 km<sup>2</sup>.

Watersheds in the Mine area are comprised of an extensive network of waterbodies, and interconnecting streams. The hydrology of these watersheds is dominated by lake storage and evaporation.

#### 2.1.2 Ice and Winter Flows

Late-winter ice thicknesses on freshwater lakes in the Mine area range between 1.0 to 2.3 m with an average thickness of 1.7 m. Ice covers usually appear by the end of October and are completely formed in early November. The spring ice melt (freshet) typically begins in mid-June and is complete by early July (Golder, 2012b).

### 2.1.3 Spring Melt (freshet) and Freeze-up Conditions

With the exception of the main outlet of Meliadine Lake, which has been observed to flow continuously throughout the year, outlets of waterbodies near the Mine typically start flowing late May or early June, followed by freshet flows in mid-to-late-June. Flows steadily decrease in July and low flows are ongoing from August to the end of October, prior to winter freeze.

### 2.1.4 Permafrost

The Mine is located in an area of continuous permafrost. The depth of permafrost is estimated to be in the order of 320 to 490 m (WSP, 2024b). The depth of the active layer ranges from about 1 m in areas with shallow overburden, up to 3 m adjacent to the lakes. The typical permafrost ground temperatures at the depths of zero annual amplitude (typically at the depth of below 15 m) are in the range of -5.0 to -7.5 °C in the areas away from lakes and streams. The geothermal gradient ranges from 0.012 to 0.02 °C/m (Golder, 2012b).

### 2.1.5 Local Hydrogeology

Continuous permafrost areas, in dominant presence in the Mine area, are subject to the following groundwater flow regimes characteristics:

- A shallow flow regime located in an active layer (seasonally thawed) near the ground surface and above permafrost, also called supraperafrost groundwater; and,
- A deep groundwater flow regime beneath the base of the permafrost, also called subpermafrost groundwater.

From late spring to early autumn, when temperatures are above 0 °C, the shallow active layer thaws. Within the active layer, the water table is projected to be a subdued replica of topography. Groundwater within the active layer flows to local depressions and ponds that drain to larger waterbodies. The talik, or unfrozen ground, beneath large waterbodies will be open. Open talik define areas of connections between supraperafrost groundwater and deep groundwater flow regime beneath the permafrost.

In a study investigating groundwater flow within the vicinity of the Meliadine site, Golder (2012a) identified that circular lakes with a minimum radius of 290 m or elongated lakes with minimum half width of 160 m, are subject to have underlying open taliks. Meliadine Lake and Lake B7 are likely to have open taliks connected to the deep groundwater flow regime.

## 2.2 Mine Development Plan

Agnico Eagle is currently mining the Tiriganiaq deposit with two open pits and one underground operation. The 2024 Water Licence Amendment extended the mine life to 2031 with the open pit mining of F Zone, Wesmeg, Pump, and Discovery deposits. A modification application was approved in 2025 for the development of a portal in Pump Open Pit 2 (PUMP02) to extend access to deposits within permafrost. The 2026 Water Licence Amendment Operational Update further extends operations through 2036, including PUMP02 development below permafrost. Agnico Eagle will continue exploration activities with the objective to extend mine life beyond 2036.

Mining facilities on surface include a plant site and accommodation buildings, ore stockpiles, a tailings storage facility (TSF), waste rock storage facilities (WRSFs), a water management system that includes collection ponds, mined-out pits, water diversion channels, retention dikes/berms, and a series of water treatment plants. The general mine site layout plan is shown on Figure 2.

## SECTION 3 • WATER MANAGEMENT CONTROLS AND STRUCTURES

There are three major sources of water at the Mine requiring management under the Mine water management system: freshwater pumped from Meliadine Lake, natural runoff from precipitation, and natural groundwater inflow to the Underground Mine. For the purpose of clarity and consistency, terminology and definitions are applied to these three main sources as follows below. These terms are applied throughout the remainder of the WMP.

- **Freshwater:** Water contained within natural water bodies (e.g., Meliadine Lake) which has not come into contact with the mine infrastructure.
- **Surface Contact Water:** Rain and snowmelt that has come into contact with the mine infrastructure and is collected within the collection ponds.
- **Saline Contact Water:** Saline groundwater which flows into the underground mine and comes into contact with the underground mine infrastructure.

A network of berms, dikes, collection ponds, mined-out pits, channels, culverts and sumps are in place and maintained to facilitate water management. Design Reports and As-Built Reports have been submitted and approved for the water management structures discussed in this section, as applicable. This section is included to summarize design and as-built information.

### 3.1 Water Management Systems

The comprehensive water management systems, as shown in Figure 5, required to support the additional deposits in the Meliadine Mine Plan per the latest Water Licence Amendment, include the following components:

- Five water retention dikes including D-DCP1, D-DCP5, D-B5North, D-B5South, and D-A6;
- Fifteen water collection ponds (CP1, CP2, CP3, CP4, CP5, CP6, CP7, CP8, CP9, CPD1, CPD2, SP1, SP3, SP4, and P3);
- Five mined-out pits for water storage (TIRI02, WES02, WES03, PUMP02 and FZONE02);
- Five dewatered waterbodies to be managed (A8, A6, B5, J6, and B34);
- Sixteen water diversion channels (Channel 1, Channel 2, Channel 3, Channel 4, Channel 5, Channel 6, Channel 7, Channel 8, Channel 9, Channel 10, Channel 11, Channel 12, Channel 13, Channel 14, Channel 15, and Channel 18);
- Three sumps (TIRI01 and Sump F1, and Sump P5);
- Eleven thermal protection berms including Channel 2 Berm, Berm 3, Berm 4, Berm CP2, Berm CP3, Berm CP4, Berm CP6, Berm CP8, Berm CP9, Berm CP7 North, and Berm CP7 West;
- Culverts as required;
- An effluent water treatment plant (EWTP);
- A saline effluent treatment plant (SETP);
- A water treatment complex (WTC) building – housing the EWTP and SETP;
- A sewage treatment plant (STP);

- An oil-water separator (OWS);
- A reverse osmosis plant (RO);
- A potable water treatment plant (WTP);
- A network of surface pumps and pipelines;
- A freshwater intake;
- Four jetties and pumping infrastructure (located at CP1, CP5, A6 and A8);
- An effluent diffuser located in Meliadine Lake; and
- An effluent diffuser located in Melvin Bay.

Surface contact water is intercepted, diverted and collected within various collection ponds/mined-out pit(s) prior to passive evaporation, treatment and/or discharge. Collection and routing of contact water is planned as follows:

- Surface contact water from CP3, CP4, and CP8 are pumped to culvert 3, just upstream of CP1, which convey the flow naturally to CP1.
- Water collected in CP5 is pumped to CP1.
- Once Lake B7 is dewatered, it will be converted into CP7 and will function as an overflow contact water storage pond for CP1, used as needed during high-flow conditions.
- Once construction is completed, the WES03 pit will serve as an intermediate reservoir, storing water from CP3, CP4, CP5, CP8, and STP for eventual discharge to Itivia Harbour via the waterline or to CP1. WES03 discharge to Itivia Harbour will be prioritized over discharge to CP1 and Meliadine Lake.
- Surface contact water from the WRSF3 area collected in CP2 and CP6 is pumped to CP1.
- CP9 will be established using the PUMP01 pit to manage contact water from the Pump area. Water from CP9 will also be pumped to CP1.
- FZONE02 pit will manage contact water from the F-zone area. Water from FZONE02 will also be pumped to CP1.

V19

Surface contact water collected in CP1 is treated for total suspended solids (TSS) at the EWTP-WTC and discharged through the diffuser located in Meliadine Lake (Section 3.10).

Saline contact water from the Underground Mine is collected in underground sumps, transported to a clarification system, and subsequently recirculated for use in various underground operations. Excess saline contact water is pumped to surface and management is planned as follows:

- Stored in Tiriganiaq Pit 2 (TIRI02) until it is unavailable.
- The PUMP02 pit will be used as a saline water sump once mining of the PUMP02 deposit is complete and will continue to capture saline runoff from the temporary Pump Underground WRSF.
- The WES02 pit will also be used as a saline water reservoir once mining of the WES02 deposit is completed.

Excess saline contact water stored on surface is treated at the Saline Effluent Treatment Plant (SETP). Further details are found in the Groundwater Management Plan.

During the mine closure, the water management infrastructure will remain in place until closure activities are completed and monitoring demonstrates that water quality is acceptable for discharge to the environment without treatment.

A list of the water management control structures already constructed at Meliadine Mine is presented in Table 1. Table 2 summarizes future water infrastructures proposed to support mining of all deposits included in the Mine Plan. Figure 5 shows the location of the respective structures over the development stages of the mine life. Final design details of these structures will also be provided to the Regulators for approval at least 60 days prior to construction, as per the Water Licence.

***Table 1: Constructed Water Management Control Structures***

Mine Phase	Infrastructure Name	Construction Status
Pre-Production Construction	Channel 1	Constructed
	Channel 2	Constructed
	Channel 3	Constructed
	Channel 4	Constructed
	Channel 5	Constructed
	Channel 6	TBD
	Channel 7	Constructed
	Channel 8	Constructed
	Culvert 1	Constructed
	Culvert 2	Constructed
	Culvert 3	Constructed
	Culvert 4	Constructed
	Culvert 5	TBD
	Culvert 6	Constructed
	Culvert 7	Constructed
	Culvert 8	Constructed
	Culvert 10	Constructed
	Culvert 11	Constructed
	Culvert 13	Constructed
	Culvert 14	TBD
	Culvert 15	Constructed
	Culvert 16	Constructed
	Culvert 18	Constructed
	Culvert 19	Constructed
	Culvert 20	TBD
	CP1	Constructed
	CP3	Constructed
	CP4	Constructed
	CP5	Constructed
	D-CP1	Constructed
	Berm CP3	Constructed
	Berm CP4	Constructed
D-CP5	Constructed	
CP1 Jetty	Constructed	
CP5 Jetty	Constructed	

Mine Phase	Infrastructure Name	Construction Status
	Saline Pond (SP1)	Constructed
	Berm 1	Constructed
	Berm 2	Constructed
	Berm 3	Constructed
	Freshwater Intake Causeway & Pump Station	Constructed
	Submerged Diffuser	Constructed
	WTP Intake	Constructed
Current Operations	CP6 and Berm CP6	Constructed
	Saline Pond 3 (SP3)	Constructed
	Saline Pond 4 (SP4)	Constructed
	CP2 and Berm CP2	Constructed
	Channel 9	Constructed
	Channel 10	Constructed
	Channel 2 Berm	Constructed
	CP9 and Thermal Berm CP9	Constructed
	Berm-4	Constructed
	Channel 11	Constructed
	Culvert 1.1B	Constructed
	Culvert J1	Constructed
	Culvert J6	Constructed
	Culvert Paste Plant	Constructed
	Culvert Explo Garage	Constructed
P3	Constructed	

**Table 2: Water Management Control Structures to be Constructed**

Water Management Infrastructure Type	Nomenclature	Location and Operational Function
Collection Ponds & Sumps	CP7	Located within the footprint of the dewatered lake B7, CP7 will be used as an overflow storage pond for CP1, used as needed during high-flow conditions
	CP8	Located south-west of the TSF, CP8 will be used to capture TSF runoff and interflow along the northwestern boundary
	CPD1	Located south of WRSF9, CPD1 will be used to contain contact water from the WRSF9 within Discovery area.
	CPD2	Located south-west of Disc01, CPD2 will be used to contain contact water from the Disc01 pit within Discovery area.
	Sump F1	Sump F1 to collect contact water from WRSF7 that has been diverted by Channel 15.
	Sump P5	Sump P5 to collect contact water from Channel 12.
Dikes	Dike D-B5North	Located north of WN01 open pit within dewatered Lake B5, D-B5North will be used to divert runoff from flowing into WN01 pit.
	Dike D-B5South	Located south of WN01 open pit within dewatered Lake B5, D-B5South will be used to collect runoff from B5 south catchment.
	Dike D-A6	Located southwest of FZO01 open pit, D-A6 will be used to divert contact water from Lake A6 from flowing into FZO01 open pit.
Berms	Berm P5	Located south of Lake B34, Berm P5 will be used to divert contact water to Channel 12 and block flow to southern natural catchment.
	Berm CP8	Located south of CP8, Berm CP8 will be used to divert water to CP8 and block flow southward to lake B7 (CP7).
	CP7 Berm North	Located northwest of CP7, Berm CP7 North will be used to preserve the



Water Management Infrastructure Type	Nomenclature	Location and Operational Function
		permafrost foundation within the dike footprint and to divert water from CP7 to Lake E3.
	CP7 Berm West	Located west of CP7, Berm CP7 West will be used to divert water from CP7 to Lake B6.
<b>Channels</b>	Channel 12	Channel 12 diverts contact water from WRSF6 (Phase 2) to Channel Sump P5.
	Channel 13	Channel 13 diverts contact water from the TSF extension to CP3.
	Channel 14	Channel 14 diverts contact water from the TSF extension to CP8.
	Channel 15	Channel 15 diverts contact water from WRSF7 towards Sump F1.
	Channel 18	Channel 18 diverts contact water from industrial pad, and fuel pad at Discovery towards the downstream CPD2.
<b>Culverts</b>	To be determined	Numerous culverts will be necessary for water conveyance through haul roads and access roads. Their exact location still needs to be confirmed based on the design of the road's overs the next years.

### 3.2 Water Management Structures Design Criteria

The water management systems meet the following criteria:

- Treated surface contact water quality will meet regulatory criteria of the Licence and MDMER (described in the Water Quality and Flow Monitoring Plan).
- Treated saline water quality will meet MDMER criteria (described in the Water Quality and Flow Monitoring Plan).
- Design capacity of the EWTP is sufficient to ensure that D-CP1 and CP1 are able to manage the surface contact water from the entire site for a 1:100 wet year spring freshet, or a 1:2 mean year spring freshet in combination with a 1:1000 return 24-hour extreme rainfall.
- D-CP5 and CP5 are able to manage the surface contact water from its catchment area for 3/7 of a 1:100 wet year spring freshet or a 1:1000 return 24-hour extreme rainfall. This design is based on an allowable 3-day delay in initiation of pumping during a 7-day, 1:100 year freshet. Design capacity of pumping from CP5 to CP1 is sufficient to ensure that remaining freshet inflows to CP5 are managed via pumping to CP1.
- Storage capacity of each of the other water management ponds (CP2, CP3, CP4, and CP6) is able to manage the surface contact water from their respective catchment area for 3/7 of a 1:100 wet year spring freshet or a 1:1000 return 24-hour extreme rainfall.
- The daily pumping rate for each of the ponds (CP2, CP3, CP4, CP5, and CP6) is designed to have sufficient pumping capacity to handle the runoff surface contact water, which would result from one day (24.4 mm) of a 1:100 return wet spring freshet plus a 1:2 return one-hour rainfall (9.8 mm).
- Storage capacity of water management infrastructure associated with the TSF extension, Pump, Wesmeg, F Zone, and Discovery mining areas are planned to allow for partial (3/7 days) or full (7/7 days) storage for the runoff volume from a 1:100 wet year, 7-day spring Freshet from each waterbody's catchment area. The requirement for partial storage follows a similar design philosophy of CP2, P3, CP4, and CP6 whereby, following 3 days of storage, water is actively

pumped to a downstream collection pond for the remaining 4 days of a 7-day Freshet. The requirement for full storage follows a similar design philosophy of CP1 whereby the facility is able to store the entirety of the runoff from the lake's catchment area. Detailed information regarding the storage capacities of these facilities will be provided following the detailed design of each facility.

- Once WES03 is mined, excess volume (4/7 of a 100-years freshet) of partial storage ponds CP3, CP4, CP5 and CP8 will be pumped to WES03. WES03 is designed to have a full-storage capacity (7/7 days) for the runoff volume from a 1:100 wet year, 7-day spring Freshet from its catchment area and for each of the collection ponds reporting to this pit.

Channel 2 to Channel 4 are in place to pass an extreme intensity flow under a 5-minute 1:100 return rainfall of 9.2 mm. Channels 9 and 10 were designed to pass an extreme intensity flow under a 5-minute 1:100 return rainfall of 5.0 mm. Channel 1 and Channel 5 to Channel 8 are designed as internal channels where any surface contact water overflowing the channels will remain within the catchment areas of various collection ponds. Hydraulic analyses indicated that very wide channels are required to pass an extreme intensity flow under a 5-minute 1:100 return rainfall of 9.2 mm. As a result, these channels were designed to have a reasonable bottom width to pass a flow with lesser intensity, but

the surface contact water overflowing the channels can be safely managed by berms or temporarily stored in a lower basin nearby. For example, surface contact water overflowing Channel 5 can be contained by Berm 3. Water overflowing Channel 7 and Channel 8 can be stored in the lower basin in the drained Pond H13, and Berm 1 combined with a mass till backfill protects the Portal No.2 entrance from flooding. Furthermore, the MULTI-PLATE at Portal No. 2 is protected by compacted, engineered structural fill. Surface contact water overflowing Channel 1 will flow through the flat ground between the Stage 1 pad and Stage 2 pad of Ore Storage Pad 2 (OP2) into CP1. Table 3 presents the design parameters for CP1 and CP5. CP2, CP3, CP4 and CP6 were built through excavation of the original ground to increase water storage capacity and prevent water levels from reaching the thermal protection berms. The as-built parameters for CP2, CP3, CP4 and CP6 are provided in Table 4 and are discussed in further detail within Tetra Tech (2022), Agnico Eagle (2019c), Agnico Eagle (2019d), and Tetra Tech (2020a).

**Table 3: As-Built Parameters for CP1 and CP5**

Pond	CP1	CP5
<b>Pond Volume at Maximum Operating Elevation under Normal Operating Conditions and Mean Precipitation Years (m<sup>3</sup>)</b>	742,075	46,674
<b>Maximum Operating Water Elevation (m)</b>	66.2	66.0
<b>Maximum Water Elevation during IDF (m)</b>	66.6	66.3
<b>Estimated Pond Volume for Water Elevation at Maximum Operating Water Elevation during IDF (m<sup>3</sup>)</b>	855,245	70,000
<b>Dike for Pond</b>	D-CP1	D-CP5
<b>As-Built Crest Elevation of Dike Collection Element (liner system) (m)</b>	67.37	66.72

**Table 4: As-Built Parameters for CP2, CP3, CP4, and CP6**

Pond	CP2	CP3	CP4	CP6
Elevated Pond Bottom Elevation (m)	41.4	53.3	51.0	51.1
Estimated Maximum Water Elevation during IDF (m)	52.0	63.0	63.0	62.0
Pond Volume at Estimated Maximum Water Elevation during IDF (m <sup>3</sup> )	48,160	44,848	48,995	67,799
Thermal Berm for Pond	Berm CP2	Berm CP3	Berm CP4	Berm CP6

### 3.3 Water Collection ponds

Seven water collection ponds (CP1, CP2, CP3, CP4, CP5, CP6, and CP9) have been constructed to date as part of the water management infrastructure. CP8 will be built over the winter of 2026 and will be in operation for the 2026 freshet. Although initially intended to serve as the primary saline water storage pond, CP7 will now serve exclusively as a surge storage reservoir for surface contact water from CP1 during high-flow periods (see Section 3.6.2). The WES03 pit will act as an intermediate reservoir, receiving water from CP3, CP4, CP5 and CP8. Table 5 presents the locations and the required operational period of the collection ponds. The locations of the nine water collection ponds are shown in Figure 2.

**Table 5: Location of Collection Pond and Required Operation Periods**

Collection Pond	Relative Location	Required Operation Period
CP1	Pond H17 and H6	Year 2017 to Mine closure
CP2	East of WRSF3	Year 2022 to Mine closure
CP3	North of Lake B7 and southwest of TSF	2019 to 2028 (covered by TSF)
CP4	Southeast of Lake B7 and south of WRSF1	2019 to 2028 (covered by WRSF1)
CP5	North of TIRI02	2017 to Mine closure
CP6	Pond H19 and north of WRSF3	Year 2020 to Mine closure
CP7	Dewatered Lake B7	Year 2028 to Mine closure
CP8	South-West of TSF	Year 2026 to Mine closure
CP9/Pump01	Within the Pump01 and Lake B36 footprint	Year 2026 to Mine closure
Fzone02	Within the Fzone02 footprint	Year 2029 to Mine closure

### 3.4 P-Area Ponds

The P-area formerly consisted of three storage ponds as part of the saline contact water management system from 2016 to 2018.

Backfilling of the P-Area cells (P1 and P2) began in Q3 of 2020 and finished in Q3 of 2021 using waste rock obtained from the underground mine and open pits to promote permafrost aggradation.

In 2024, cell P3 was decommissioned and backfilled to serve as a laydown and storage pad. Design of the P3 backfilling included a ditch surrounding the pad and a 1.3 m deep sump excavated into the overburden at the west extremity of the pad. The ditch can safely pass an extreme intensity flow under a 5-minute 1:100 return rainfall of 5.0 mm. Water levels within the sump are controlled by a level-indicator switch which provides a freeboard greater than 0.5 m below (66.8 m) the core elevation in the DP3-A berm (67.5 m) and the crest of the P3 laydown pad. Surface runoff to the sump is managed by pumping water over the DP3 containment structure into CP5. TDS monitoring in P3 over several years has demonstrated a sufficient degree of flushing has occurred such that the risk of salt contamination from the former presence of saline water in cell P3 is minimized and the subsequent downstream impact on CP5 TDS is negligible.

Table 6 presents the design criteria of the P3 sump. Figure 3 presents the layout of P3 pad.

**Table 6: P3 Sump Design Criteria**

Design criteria	Sump P3
<b>Sump drainage area</b>	23,560 m <sup>2</sup>
<b>1:100 24h rainfall event</b>	59.9 mm
<b>Total inflow</b>	1,270 m <sup>3</sup>
<b>Minimum freeboard during IDF</b>	0.5 m
<b>Maximum Design Water Elevation</b>	66.8 m
<b>Sump Bottom Elevation</b>	64.6 m
<b>Storage Capacity</b>	894 m <sup>3</sup>
<b>Minimum Pumping Rate</b>	20 m <sup>3</sup> /h
<b>Level-Indicator Switch Elevation</b>	65.5 m

### 3.5 Contaminated Snow Cell

A contaminated snow cell is used to store snow containing hydrocarbons (i.e., snow on which spills occur). The contaminated snow cell was constructed in 2017 (Agnico Eagle, 2017a) and is currently in place as a contingency measure for contaminated snow storage over the winter (refer to the Freshet Management Plan). Upon snowmelt, water within the contaminated snow cell is transferred to the Landfarm for treatment at the oil-water separator (Section 3.9.5).

The snow cell is lined with a polyethylene liner to avoid seepage of melting snow into the surrounding environment. The cell is designed to contain a volume of 1,500 m<sup>3</sup> of snow and to contain 930 m<sup>3</sup> of water at a water surface elevation of 69.5 m.

### 3.6 Saline Ponds

#### 3.6.1 Existing Saline Ponds

Saline Pond 1 (SP1) was constructed in Q3 2016 to accommodate excess saline contact water from the Underground Mine. SP1 is located north of CP5 (Figure 2). Table 7 summarizes the Saline Pond capacity for storage and maximum designed operating water levels.

Saline Pond 2 (SP2) was constructed within the footprint of TIRI02 in Q2 2019 as a temporary saline contact water storage pond on site, accommodating excess saline contact water from the Underground Mine. In Q2 2020 SP2 was decommissioned to allow mining of Tiriganiaq Pit 2. Saline contact water stored in SP2 was emptied into Saline Pond 4 (SP4) which was commissioned in March of 2020.

Saline Pond 3 (SP3) was constructed within the footprint of P-Area Pond 3 (P3). Construction of SP3 was completed in Q2 2019. SP3 is part of the medium-term groundwater management strategy, that consists of treating groundwater from the Meliadine Underground with respect to quality standards and discharge the treated water effluent into Melvin Bay. SP3 is used to store the treated water exiting the former Saline Effluent Treatment Plant (SETP) (i.e., the SETP not within the WTC) before being discharged to sea.

Saline Pond 4 (SP4) was temporary in nature and allowed for the dewatering of SP2 to facilitate construction of Tiriganiaq Pit 2 (TIRI02) while providing additional storage for saline contact water from the underground mine. SP4 was constructed in bedrock within the footprint of Tiriganiaq Pit 1 (TIRI01) (Figure 4). SP4 was dewatered to TIRI02 in 2021 to facilitate mining beneath the facility and allow for mining to continue in TIRI01 in this area. In 2023, development of TIRI01 extended into SP4 and thus the pond no longer exists.

In Q3 2021, mining in TIRI02 was stopped and the pit was subsequently converted to a saline water storage facility. TIRI02 has a total saline water capacity of 1,616,554 m<sup>3</sup> and will be used to store the saline contact water pumped out of the underground mine. Further information on the saline contact water storage strategy is provided in the Groundwater Management Plan.

Groundwater from the underground mine is pumped to TIRI02 where it will remain in storage until it is treated for discharge to sea (see Section 3.11 or Groundwater Management Plan). Water stored in the saline ponds is isolated from the surface runoff collection system and will thus not be discharged to Meliadine Lake.

**Table 7: Storage Capacities for Saline Pond 1 (SP1) and Tiriganiaq Pit 2 (TIRI02)**

Item	SP1	TIRI02
Maximum Operational Water Elevation (m)	62.9	62.0
Maximum Water Capacity (m <sup>3</sup> )	32,686*	1,616,554

\* Tetra Tech (2017) maximum operating capacity, not including IDF storage

### 3.6.2 CP7 (Lake B7) to be Constructed

Once Lake B7 is dewatered, it will become Collection Pond 7 (CP7). Although initially intended to serve as the primary saline water storage pond for underground mine water and saline contact water from saline ponds, this function has been reassigned to WES02 Pit. As a result, CP7 will now serve exclusively as a surge storage reservoir for surface contact water from CP1 during high-flow periods.

### 3.7 Water Storage in Mined-Out Pits

Mined-out pits at the Meliadine Mine play a critical role in the integrated water management strategy, serving as both temporary and long-term storage facilities for contact and saline water. These pits are repurposed to manage water volumes generated during operations, thereby reducing the need for additional surface infrastructure.

- PUMP02 pit will be used as a saline water sump once mining of the deposit is complete and will capture saline runoff from the Pump Underground WRSF.
- Once WES02 will be completed, it will replace TIRI02 as the primary storage facility for excess saline contact water pumped from the underground mine, which will later be treated at the SETP before discharge to Itivia Harbour.
- WES03 functions as an intermediate reservoir for surface contact water collected from CP3, CP4, CP5, and CP8. During the open-water season only, water from the STP will be sent to WES03. Water stored in WES03 is designated to Itivia Harbour via the waterline.

### 3.8 Water Diversion Channels, Dikes and Berms

The following sections provide details on existing water management infrastructures currently required for mining the Tiriganiaq deposit. Water management infrastructures to be constructed to support the Mine Plan are summarized in Table 1. Details will be updated in the Water Management Plan as these structures progress into the detailed design phase.

#### 3.8.1 Water Diversion Channels

Nine water diversion channels (Channels 1 to 5, and 7 to 10) have been constructed and form part of the surface contact water management infrastructure. Construction of Channel 6 is tentative based on future water management strategies downstream of the P-area. Construction of Channels 9 and 10 was completed in Q2 2022. Channel 11 was completed in Q2 2025 and collects and diverts the runoff water from the proposed WRSF6 catchment area to CP9/Pump01 Pit. The as-built and design parameters for the water diversion channels are presented in Table 8.

**Table 8: As-Built and Design Parameters for Channels**

Channel	Approximate Total Length (m)	Bottom Width (m)	Side Slopes	Rip-rap Thickness (m)	Minimum Bottom Slope Gradient (%)	
1 (As-built)	528	3	3(H):1(V)**	0.3 to 0.5	0.2	
2 (As-built)	270	1.257	1.82(H):1(V)	0.277	0.30†	
3 (As-built)	656	1.2 to 2.4 or 0.8 to 3.3*	1.8(H):1.0(V) to 3.5(H):1.0(V)	0.3†	5.3 (upper)	0.4 (lower)
4 (As-built)	930	1.0 to 1.7 or 0.8 to 4.5*	1.8(H):1.0(V) to 5.0(H):1.0(V)	0.37	2.1 to 5.3 (upper)	0.1 to 4.2 (lower)
5 (As-built)	429†	2.3 to 2.9	1.9(H):1(V)	0.2	0.17†	
6	69	1	3(H):1(V)	0.3	0.44	
7 (As-built)	240	2	3(H):1(V)	0.59	0.8 (Avg.)	
8 (As-built)	114	2.4	3(H):1(V)	0.3	1.4 (Avg.)	
9 (As-built)	713	1.55 to 3.13 (avg 2.41)	1.6(H) to 2.5(H):1(V)	0.48	0.7	
10 (As-built)	200	2.03 to 3.27 (Avg 2.64)	1.7(H) to 2.7H:1(V)	0.34	1.5	
11 (Design)	870	2.0	2.5(H):1.0V	0.3	2.0 (Avg.)	

\* 1 m bottom width for first 100 m upstream section, and 2 m bottom width for the remaining channel section

\*\* Except from Sta. 0+050 to 0+130: 2(H):1(V)

† As-built parameter values not available; value displayed is from design

### 3.8.2 Water Retention Dikes and Berms

In general terms, “dikes” were constructed with impervious liner systems and “berms” are constructed with entirely till cores. With the extension of the mine within the Pump area, Berm 4 will be used to divert runoff water from WRSF6 to Channel 11 and CP9, and to prevent contact water from flowing into the receiving environment.

Water retention dikes D-CP1 and D-CP5 have been designed as a zoned earth fill dams with a geomembrane liner keyed into the permafrost foundation to limit the seepage through the dike and its foundation. The characteristics of the dikes and berms required for the WMP are summarized in Table 9.

**Table 9: As-Built and Design Parameters for Water Retention Dike/Berm**

Dike/Berm	Approximate Maximum Height (m)	Maximum Elevation (m)	Maximum Head of Water Retained (m)
D-CP1	6.6	68.5	3.6
Berm CP2	5.07	58.6	0
Berm CP3	4.9	69.9	0
Berm CP4	5.0	69.1	0
D-CP5	3.3	67.3	1.4
Berm CP6	6.0	68.0	0
DP1-A	3.7	70.5	68.5
DP1-B	3.4	70.7	68.7
DP2-A	4.0	69.5	67.5
DP3-A	3.4	69.0	67
Berm1	2.6	69.0	0
Berm2	1.5	varies	0
Berm3	2.76	67.37	0
Channel 2 Berm	1.7	71.0	1.5
Berm 4	1.5	74.0	0

### 3.8.2.1 Thermal Monitoring

Horizontal Ground Temperature Cables (GTCs) are installed along the key trenches of D-CP1 and D-CP5 at a depth of approximately 3 m below the original ground level. These installations are in place to verify that the foundations remain frozen and dike integrity is not compromised. D-CP1 and D-CP5 also contain vertical GTCs installed to an approximate depth of 15 m below the crest of each dike. Thermal berms of CP2, CP3, CP4 and CP6 contain vertical GTCs installed to approximately 8 m below original ground elevation to monitor the thermal performance of the foundation materials. Thermal records collected from these sensors provide temporal analysis of vertical temperature profiles to assess whether the structures are performing as designed.

D-CP1 and D-CP5 readings are obtained, recorded, and assessed weekly during open water season and monthly after freeze-up. Data loggers are set to record temperatures in the dikes every 12-hours. Reading frequency at the thermal berms is generally monthly during the first year following construction and quarterly thereafter. The measured readings are analyzed by an Agnico Eagle geotechnical engineer and are reported in the annual geotechnical inspection report.

In addition to thermal monitoring, visual geotechnical inspections of water management structures are currently performed, as described in Section 3.12 below.

### 3.9 Freshwater Intake

Freshwater usage at the Mine includes potable uses, fire suppression, make-up water for the mill, and other operational requirements, such as drilling water, dust suppression, paste backfill production, and uses at the washbay. The main freshwater intake is located northeast of the industrial pad in Meliadine Lake, depicted in Figure 5. The intake consists of vertical filtration wells fitted with vertical turbine pumps that supply water on demand. Both intake pipes are located 7 m deep in the lake and are fitted with a screen of an appropriate mesh size to ensure that fish will not be entrained and shall withdraw water at a rate such that fish do not become impinged on the screen (NWB, 2021).

### 3.10 Water Treatment

Contact water will be treated (if necessary) to meet Licence requirements prior to being discharged to the environment. TSS mitigation techniques (i.e., attenuation ponds, silt screens, etc.), oil separation treatment, the STP, the SETP, the RO Plant, and the EWTP are used accordingly at various locations at the Mine prior to water being transferred to collection ponds and/or prior to effluent discharge to Meliadine Lake or Melvin Bay. Water quality criteria are discussed in Section 6 and in the Water Quality and Flow Monitoring Plan.

#### 3.10.1 Freshwater Treatment Plant (WTP)

Freshwater from Meliadine Lake is treated in the WTP before being directed to the camp areas for potable (domestic) water uses. The design flow rate for freshwater for the main camp and accommodations is 216 m<sup>3</sup>/day. In the WTP, freshwater is pumped through cartridge filters, then pumped through ultraviolet units, and finally treated with sodium hypochlorite (chlorine). The treated water is stored within a potable water tank. Potable water is monitored according to the Nunavut Health Regulations for total and residual chlorine and microbiological parameters. Operation and maintenance details for the WTP can be reviewed in the Operational & Maintenance Manual – Water Treatment Plant (Agnico Eagle, 2020a).

#### 3.10.2 Sewage Treatment Plant (STP)

Wastewater from the accommodation complex and from satellite sewage tanks will be treated in the STP using a membrane bioreactor process before being directed to CP1 and, when available, to the WES03 Pit. Operation and maintenance details for the STP can be reviewed in the Operational & Maintenance Manual – Sewage Treatment Plant (Agnico Eagle, 2021a). Sludge is pressed using a volute dewatering unit and stored in the active deposition zone of WRSF1 or WRSF3 to ensure coverage with waste rock.

#### 3.10.3 Saline Water Treatment Plant (SWTP)

In 2018, Agnico Eagle constructed and commissioned a Saline Water Treatment Plant (SWTP) consisting of two evaporator-crystallizers (SaltMakers) to treat saline contact water. The SWTP removes total suspended solids (TSS), calcium chloride (CaCl<sub>2</sub>), sodium chloride (NaCl), metals, phosphorous (P), and nitrogen compounds from the influent saline contact water. Further specifications of the SWTP can be found within the SWTP Design Report (Agnico Eagle 2018) and the SWTP As-Built Report (Agnico Eagle 2019a).

In March 2020, operation of the plant was suspended due to poor performance coupled with high energy

consumption and plant safety concerns and completed decommissioning will happen in 2026. The SWTP is not currently a component of the groundwater management strategy. More information regarding the groundwater management strategy can be found in the Groundwater Management Plan.

### **3.10.4 Water Treatment Complex (WTC)**

The WTC is a building designed to house both the EWTP and SETP. The design rationale for the WTC is to address concerns with the stability of the concrete slab at the previous EWTP building location. Additionally, the WTC provides a centralized building for contact water treatment, allowing for improved operational synergy.

Construction of the WTC commenced in Q3 2020. Further information regarding the WTC can be found in the As-Built Report (Agnico Eagle 2021b).

#### **3.10.4.1 Effluent Water Treatment Plant (EWTP)**

The installation of the EWTP within the WTC (EWTP-WTC) was completed in Q2 2021 to allow for discharge to Meliadine Lake during the open water season.

The purpose of the EWTP-WTC (Actiflo® model ACP-700R) is to reduce Total Suspended Solids (TSS) to a target maximum concentration of 15 mg/L from the influent surface contact water pumped from CP1 prior to its discharge through the diffuser into Meliadine Lake.

The EWTP is designed to meet the minimum required rate of 12,000 m<sup>3</sup>/d per the design requirements of dike D-CP1 (Tetra Tech, 2016b). While the EWTP equipment has an operational range up to 28,000 m<sup>3</sup>/d, the current system is configured to operate a maximum discharge rate of 18,000 m<sup>3</sup>/d to prevent overpressuring in the HDPE line that conveys water from the EWTP to the diffuser.

Further information regarding EWTP-WTC operation can be found in the EWTP-WTC Operation and Maintenance Manual (Agnico Eagle 2021c).

Trigger limits for stopping discharge are in place at the EWTP-WTC as a component of TSS, TDS, and pH exceedance mitigation during periods of discharge. These trigger limits are derived from a regression analysis of TSS concentration as a function of turbidity, and TDS as a function of specific conductivity. The regressions are developed using MEL-14 grab sample laboratory measured specific conductivity and turbidity readings paired with corresponding TDS and TSS results. Rating curves are then applied to continuous *in situ* specific conductivity and turbidity readings taken from internal probes within the EWTP-WTC prior to discharge to approximate TDS and TSS, respectively. Trigger limits for pH also prevent the discharge of non-compliant effluent using internal probes measuring *insitu* pH. When a trigger limit is reached, the EWTP-WTC stops discharging into Meliadine Lake immediately and begins recirculating treated water to CP1.

Agnico Eagle will continue to gather calibration/confirmatory paired samples in the future to actively increase the number of data points and strengthen the turbidity-TSS and conductivity-TDS correlations.

#### **3.10.4.2 Saline Effluent Treatment Plant (SETP)**

Prior to discharge of saline effluent to Itivia Harbour (see Section 3.11 and Groundwater Management Plan), saline contact water is store on site (Section 3.6). Saline contact water as well as surface contact water is pumped to the SETP for ammonia nitrogen and total suspended solids treatment. Treated saline contact water will meet MDMER end-of-pipe discharge criteria. Initial treatment includes a clarification unit for TSS removal.

Final phase of the Commissioning of the TSS treatment component of the SETP within the WTC (SETP-WTC) is expected to take place in Q3 2026. Further information on the SETP-WTC design for the TSS treatment component can be found in Agnico Eagle (2021d). Operation of the SETP-WTC and subsequent discharge will occur following construction and commissioning of the waterline (more information can be found in the Groundwater Management Plan). Once mining of the deposit in WES02 is completed, all saline contact water will be collected in WES02 and routed to the SETP-WTC where water will be treated prior to discharge to Itivia Harbour. Final discharge point (FDP) samples will be analyzed at an accredited laboratory as per MDMER requirements, as discussed within the Water Quality and Flow Monitoring Management Plan.

#### **3.10.4.3 Sludge management**

Sludge produced as part of the TSS removal processes at the WTC is discharged into saline water storage. Since its commissioning in 2021, the EWTP-WTC has discharged approximately 50 m<sup>3</sup>/day of sludge in TIRI02 (when in operation), consistent with the expected value presented in its design report (Tetra Tech, 2022a). According to the SETP-WTC design report, this plant is expected to produce an additional 450 m<sup>3</sup>/day of sludge (when in operation). The sludge produced by the TSS removal area of the SETP-WTC will have similar characteristics to the sludge produced at the EWTP- WTC, considering the treatment processes are the same.

The WTC sludge is sampled monthly for deleterious substances found in Table 1 of Schedule 4 of the MDMER, to determine potential impact on the receiving saline ponds. Saline ponds are also sampled periodically for the same parameters.

Since 2021, available data suggests that none of the deleterious substances found in Table 1 of Schedule 4 of the MDMER have increased in concentration in TIRI02, except for Total Suspended Solids (TSS) and ammonia nitrogen. The loading of ammonia nitrogen in saline contact water is a known phenomenon at Meliadine, attributed to the dissolution of undetonated explosives from the underground mine. The increase of TSS in TIRI0 2 may in part be a consequence of discharging WTC sludge in saline water storage but is not deemed problematic. All saline water will be treated by the SETP-WTC for TSS removal prior to discharge to the Itivia Harbour.

#### **3.10.5 Oil-Water Separators**

An oil-water separator is installed at the Landfarm. The oil-water separator located at the Landfarm is used to treat both direct precipitation to the Landfarm footprint and melt from snow containing hydrocarbons (i.e., snow on which spills occur) that is stored either in the Landfarm or in the contaminated

snow cell over winter (Section 3.4). Treated water is analyzed for benzene, toluene, ethylbenzene and xylene (BTEX), lead, and oil and grease prior to discharge to CP1 or used on the windrows to increase moisture content, as required. Hydrocarbons removed from water are stored and managed as hazmat.

A second oil-water separator is applied to treat water from the maintenance shop wash bay, in which mining equipment from both surface and underground operations undergo cleaning (Section 4.1.6). Treated water is analyzed for BTEX, lead, and oil and grease prior to discharge to CP1 or saline ponds depending on *in situ* specific conductivity applied to approximate TDS concentrations. Hydrocarbons removed from water are stored and managed as hazmat.

### 3.10.6 Reverse Osmosis Plant (RO)

A reverse osmosis (RO) treatment plant is used to treat marginally saline runoff water captured by site water management infrastructure that would otherwise be directed to saline water storage. The application of the RO through these means is intended to reduce storage requirements of saline water on site until the Waterline is operational. Permeate water produced by the RO – treated water of low salinity that passes through the semi-permeable membranes – is directed to CP1. Brine water – high salinity water rejected by the semi-permeable membranes – is currently directed to TIRI02.

Efficacy of treatment is generally dependent on the quality and homogeneity of water being treated. As TDS of influent water increases, pressure against the semi-permeable membranes increases, resulting in a lower recovery of treated permeate and a greater volume of rejected brine. However, the treatment flow rate can be lowered to reduce pressure and improve permeate recovery in feed water with a high concentration of TDS. Other water quality constituents such as the concentrations of TSS, organic content, and certain minerals in the feed water may also negatively affect the performance of the RO. As size exclusion is the mechanism driving treatment, the concentration of TDS in the permeate generally remains below 1,000 mg/L (average for 2022 was 447 mg/L), but can be influenced by feed water quality and treatment rates. Consequently, the TDS concentration in the brine by-product is primarily the difference in mass of feed water solutes and mass of permeate water solutes per unit of brine volume. Additionally, more stable quality conditions or homogeneity of the water source used to feed the RO allows a better adjustment of the treatment settings and thus an optimization of the recovery rate.

The treatment rate of the RO is primarily limited by the actual capacity and size of the plant, in addition to the influence of previously mentioned water quality factors. A rate of approximately 2,000 m<sup>3</sup>/day has been achieved with a recovery of 80% (i.e. 1,600 m<sup>3</sup>/d and 400 m<sup>3</sup>/d of permeate and brine produced, respectively) where influent TDS was approximately 3,500 mg/L. Depending on the objective of treatment (e.g. volume targets versus quality targets) a lower recovery rate may be used to ensure brine quality discharged to saline storage meets a desired TDS criteria, resulting in the allowance of feed water with much higher TDS while still treating water at an appreciable flow rate. For example, feed water with a TDS concentration of approximately 12,000 mg/L has been treated at a rate of approximately 1,500 m<sup>3</sup>/d with a permeate recovery rate of 53%.

In addition to the treatment of marginally saline runoff, the plant may also be used to treat stratified layers

of low salinity water in the saline ponds. The cause of low salinity water in the saline ponds is assumed to be driven by the downward exclusion of TDS during ice formation in addition to poorly mixed runoff inflows. This results in a relatively homogeneous stratified layer of water with a lower concentration of TDS overlaying more saline water in storage. Removing the marginally saline water from saline storage increases storage capacity for saline contact water from the underground mine.

### **3.11 Meliadine Lake Discharge Diffuser**

The discharge diffuser is the final surface contact water effluent discharge location for the Mine. The overall purpose of the diffuser is to discharge water from CP1 (at sampling station MEL-14) to Meliadine Lake while providing minimal environmental impacts to the Lake. The effluent mixing will be dependent on ambient currents in Meliadine Lake, driven by wind during the open water period. The diffuser modelling was initially conducted by Golder Associates Ltd. (Golder, 2015) and updated design progress was reported by Tetra Tech EBA (Tetra Tech EBA, 2016). Further updates to the diffuser model were completed by Tetra Tech in support of the Water Licence Amendment (Tetra Tech, 2020).

### **3.12 Saline Water Discharge to Sea**

Currently due to sufficient forecasted storage capacity in TIRIO2 until 2028, saline water on site is managed through storage and treatment of marginally saline water. The continuous hauling operation stopped following the approval of the waterline to discharge to sea (section 3.3.3) under the Amendment 002 of the NIRB Project Certificate No. 006 issued on March 2<sup>nd</sup>. Once in operation, the waterline will be used in combination with the SETP-WTC to discharge treated saline water to Melvin Bay. Operation and maintenance of the waterline system is described in Appendix A. Detailed information regarding treatment and discharge criteria are provided in the Groundwater Management Plan.

### **3.13 Water Management Structure Monitoring**

Pursuant to Part E, Item 18 of the Licence, Agnico Eagle will carry out weekly inspections of all Water management structures during periods of flow and monthly thereafter. The records will be maintained for review upon request of an Inspector. More frequent inspections may be required at the request of an Inspector. Inspections will focus on structures and conditions detailed in Sections 3.13.1 to 3.13.5 to follow.

#### **3.13.1 Culvert and Water Crossing Inspections**

Culverts listed in Section 3.1, as well as culverts and water crossings along the All Weather Access Road (AWAR), Bypass Road, and at the Itivia site will be inspected for the following conditions. These inspections also satisfy the monitoring procedures outlined in the Sediment and Erosion Management Plan:

- Damage to the inlet or outlet of the culvert which may impede flow capacity;
- Bed erosion upstream and downstream of watercourse crossing structures;
- Scour under bridge abutments and abutment foundations;
- Erosion along cutslopes and fillslopes of embankments (rill and gully erosion);
- Blockages within the culvert including snow, ice, debris; and
- Snow cover or snow piles which would prevent routing of water towards the inlet of the culvert (only applicable prior to freshet).

In the case that any of the above conditions are observed, corrective actions will be taken to optimize culvert/water crossing function and integrity.

### 3.13.2 Collection Pond Inspections

Water collection ponds discussed in Section 3.3 and P3 pond discussed in Section 3.4 will be inspected for the following conditions:

- Laboratory water quality results as a trigger to implement mitigation actions;
- Unplanned inputs via surface runoff which are not part of the water management system; and
- Water level elevation above the operating manual maximum.

In the case that any of the above conditions are observed, corrective actions will be taken to prevent unaccounted losses of available water capacity or potential compromise to dike integrity.

### 3.13.3 Dike and Thermal Berm Inspections

Dikes and thermal berms discussed in Section 3.6.2 are inspected to track natural (expected) movement of the structure. Pertaining to dikes, a “master” sketch of all the issues that were documented in the past is maintained as a means to spot any changes/new issues. Inspections focus on the upstream slope, the crest, the downstream slope, and downstream toe and observations include the following:

- New areas of movement/deterioration not previously documented;
- Changes to previously documented areas of movement/deterioration;
- Seepage through the downstream slope;
- Water presence in downstream channel/sump; and
- Areas of movement/deterioration of downstream channel/sump (where present).

Any issues or potential problems identified will be addressed accordingly by the Geotechnical Engineer in order to mitigate risks and maintain dike integrity.

### 3.13.4 Water Diversion Channel and Berm Inspections

In addition to the water management structures requiring inspections under the Water Licence, Agnico Eagle will carry out inspections of channels on site listed for the following conditions:

- Obstructions to flow (ice, debris);
- Inflows not part of the water management system;
- Structural failure of channel banks;
- Seepage through water diversion berms resulting in water movement to areas not planned within the water management system; and
- Erosion of diversion berms (i.e., undercutting, slope failure).

In the case that any of the above conditions are observed, corrective actions as directed by the Geotechnical Engineer will be taken if there is potential for compromise effectiveness of the channel function or potential for unplanned impact to water quality or quantity in associated collection ponds.

## SECTION 4 • WATER MANAGEMENT STRATEGY

A brief summary of the water management strategy during the operation of the Mine is presented as follows:

- Surface contact water from key mine infrastructure is diverted and/or collected in collection ponds (CP1, CP2, CP3, CP4, CP5, CP6, CP7, CP8, CP9, and the Saline Ponds).
- The collected surface contact water is pumped to CP1 and/or WES03 pit; water collected in CP1 may be reused for operational purposes and/or treated by the EWTP-WTC prior to discharge via the diffuser into Meliadine Lake whereas, WES03 pit functions as an intermediate reservoir, ultimately conveying water to Itivia Harbour via the waterline.
- CP7 has been designated as an overflow storage pond for CP1 during high-flow events.
- Surface contact water in TIRI01 and PUMP02 Pit will be collected in a sump and, depending on salinity, pumped to a collection pond or to a saline pond.
- Saline contact water from the Underground Mine (i.e., saline groundwater) will be contained in underground sumps and reused for mining operations. Excess saline contact water volumes will be stored in TIRI02 pit, PUMP02 Pit, and WES02 pit until the waterline is commissioned and saline water can be treated for discharge to Itivia Harbour.
- Constructed within the footprint of PUMP01, CP9 will be used to capture the runoff from the PUMP area including WRSF6. Future Pits from the PUMP area (i.e. PUMP04 and PUMP02 prior to being used for excess saline storage) will also be pumped to CP9 prior to transfer to CP1.
- FZONE02 Pit will be used to capture the runoff from the F-zone area including WRSF7 and water collected will also be transferred to CP1.

Details regarding the collection facilities for new project areas will be described in future updates of the Water Management Plans as the mine plan advances. Water management during closure is detailed in Section 7.

The Meliadine Mine Freshet Management Plan includes the Freshet Action Procedure and the Snow Management Procedure for the Mine. Table 10 and Table 11 summarizes the overall contact water management plan for the existing and future key infrastructure respectively, with initial water collection locations and final water destinations. The plans for water management at key areas are described in the subsequent sections.

**Table 10: Existing Water Management Infrastructures**

Contact Water Source	Initial Contact Water Collection Location	Final Contact Water Collection Location
Industrial Site Pad Area (camp/process plant area)	CP1	CP1
WRSF1 Area	CP1, CP4 and CP5	
WRSF3 Area	CP2 and CP6	
Dry Stack TSF Area	CP1, CP3, and CP8	

Contact Water Source	Initial Contact Water Collection Location	Final Contact Water Collection Location
Ore Storage Pad 2 (OP2)	CP1	
Landfill	CP1	
Landfarm (biopile)	Sump within Landfarm	To CP1 after oil separation
Maintenance Wash Bay	Retention Tank	CP1 or surface saline storage (based on effluent salinity) after oil separation
TIRI01	Open pit sumps	Salinity based - CP4, CP5, SP1, or TIRI02.
Tiriganiaq underground	Sumps in underground mine	Sumps in underground mine, TIRI02/WES02 then discharged to sea

**Table 11: Water Management Infrastructures to be Constructed**

Pond/ Treatment	Source Water	Receives Water From	Routes Water To
A6	Contact Water	A6	CP1
TIRI03	Contact Water	TIRI03	CP5
PUMP02	Saline Water	PUMP UG Pump Saline WRSF	TIRI02 (if available) or SP1
WES01	Contact Water	WES01	CP1
WES02	Saline Water	TIRI02 SP1	WES02 (after treatment), which discharges to Itivia Harbour via Waterline
WES03	Contact Water	CP3 CP4 CP5 CP8	discharges (in order of priority) to Itivia Harbour via Waterline, then Meliadine Lake via EWTP
WES04	Contact Water	WES04	CP1
WEN01	Contact Water	WEN01	CP1
CP7	Contact Water	CP1 (Contingency storage for CP1)	discharges (in order of priority) to Itivia Harbour via Waterline, then Meliadine Lake via EWTP
B5 North	Contact Water	B6	CP1
B5 South	Contact Water	B34	CP1
FZONE02	Contact Water	FZONE01 FZONE02 FZONE03 SUMPF1	CP1
SUMPF1	Contact Water	WRSF7	FZONE02
CPD2	Contact Water	CPD1 Laydown Area (Discovery) Facilities Area (Discovery)	WES02
CPD1	Contact Water	WRSF9	CPD2

#### 4.1 Key Water Management Activities

Current activities and planned construction schedule for water management infrastructures required for the WMP to support the Mine Plan are summarized in Table 12. Water management activities during closure are described in Section 7.

**Table 12: Completed and Planned Key Water Management Activities**

Mine Year	Major Water Management Activities and Sequence
Pre-Construction (2015)	<ul style="list-style-type: none"> <li>• Started to re-use saline contact water</li> <li>• Dewatered top 0.5 to 1.0 m of fresh water in Pond H17</li> <li>• Constructed Channel 2</li> </ul>
Pre-Construction (2016)	<ul style="list-style-type: none"> <li>• Dewatered H17 into Meliadine Lake</li> <li>• Started construction of D-CP1 to impound CP1</li> <li>• Started construction of D-CP5 to impound CP5</li> <li>• Dewatered Pond A54 in Q3 of Year -4 and pumped the water to CP1</li> <li>• Constructed Saline Pond 1 (SP1) for additional saline contact water storage</li> <li>• Constructed and operated P-Area Containment Ponds</li> <li>• Started to store the excess saline contact water from the underground mine at surface</li> <li>• Implemented and tested evaporators at P-Area to reduce saline contact water volumes stored at surface</li> <li>• Constructed trenches down gradient from DP1-B and DP3-A to be able to pump collected water and pump back to P1 and P3, respectively</li> <li>• Constructed Channel 5</li> <li>• Installed Culverts 3 and 4</li> </ul>
Pre-Construction (2017)	<ul style="list-style-type: none"> <li>• Completed construction of D-CP1, jetty and Pumping station CP1</li> <li>• Completed construction of D-CP5, jetty and Pumping station CP5</li> <li>• Started construction Channel 1</li> <li>• Constructed Berm 3</li> <li>• Constructed freshwater intake in Meliadine Lake and installed pumping station</li> <li>• Constructed Lv75 water stope for additional underground saline contact water storage</li> <li>• Installed Culvert 13</li> <li>• Started to treat sewage from Sewage Treatment Plant (STP) and pump the treated sewage from STP to CP1</li> <li>• Started to pump the surface contact water from CP5 to CP1 for treatment (solids removal)</li> <li>• Started to pump water collected in trenches, down gradient from D-CP1, D-CP5, DP1 and DP3 to the associated containment pond</li> <li>• Started to pump the water from the Type A Landfarm to CP1 after oil/water separator treatment</li> <li>• Started to pump water from washbay to underground for storage until a biological treatment unit for hydrocarbon reduction/removal arrives at the site</li> </ul>
Pre-Construction (2018)	<ul style="list-style-type: none"> <li>• Completed construction of Channel 1</li> <li>• Started construction Channel 3, Berm CP3 and Pond CP3</li> <li>• Installed Culverts 1, 2, 15 and 16</li> <li>• Constructed Berm 2</li> <li>• Started to pump the surface contact water from CP1 to EWTP for treatment prior to discharge via the diffuser to Meliadine Lake</li> <li>• Pumped the solids sludge from EWTP to CP1. To limit recirculation of the sludge within CP1, the discharge of the sludge was located away from the EWTP intake</li> <li>• Started diversion of surface contact water from industrial pad to CP1 via Channel 1</li> <li>• Constructed and commissioned (in Q4) SWTP to discharge to CP1.</li> </ul>

Mine Year	Major Water Management Activities and Sequence
<b>Pre- Construction (2019)</b>	<ul style="list-style-type: none"> <li>• Constructed SP2 within footprint of TIRIO2 and began storing excess saline contact water</li> <li>• Installed culverts 7, 8, 10, 11 and 20</li> <li>• Constructed Channels 7 and 8 and Berm 1</li> <li>• Completed construction of Channel 3, Berm-CP3 and Pond CP3 and started to collect surface contact water</li> <li>• Constructed Channel 4, Pond CP4 and Berm-CP4 and started to collect surface contact water</li> <li>• Started to pump the surface contact water in Ponds CP3 and CP4 to the partially drained Pond H13 where the water flows through Channel 1 into CP1</li> <li>• Constructed, commissioned, and started discharge of saline water through the discharge to sea diffuser system</li> <li>• Partially dewatered Ponds H19 and H20 in Q3 of Year -1 by pumping water to the EWTP for discharge to Meliadine Lake</li> <li>• Started construction of Saline Pond 4 (SP4) within footprint of TIRIO1</li> </ul>
<b>2020</b>	<ul style="list-style-type: none"> <li>• Completed construction of SP4</li> <li>• Constructed Pond CP6 and Berm CP6</li> <li>• Transferred SP2 into SP4</li> <li>• Decommissioning of evaporators</li> <li>• Started to pump surface contact water in CP6 to CP1</li> <li>• Started to pump surface contact water collected in TIRIO2 to CP5</li> <li>• Started decommissioning of P1 and P2 (P-Area) by backfilling with waste rock</li> <li>• Decommissioning of SWTP</li> </ul>
<b>2021</b>	<ul style="list-style-type: none"> <li>• Start to pump surface contact water collected in TIRIO1 to TIRIO2</li> <li>• Construct and commission EWTP within WTC (EWTP-WTC)</li> <li>• Complete conversion of TIRIO2 to saline contact water storage facility</li> <li>• Dewater SP4 and SP1 into TIRIO2</li> <li>• Start pumping excess saline contact water from underground mine to TIRIO2</li> <li>• Finish decommissioning P1 and P2 (P-Area) by backfilling with waste rock</li> <li>• Pump EWTP and SETP sludge to saline contact water storage</li> </ul>
<b>2022</b>	<ul style="list-style-type: none"> <li>• Constructed Pond CP2 and Berm CP2</li> <li>• Constructed Channels 9 and 10</li> <li>• Store marginally saline water into SP1</li> <li>• Pump water from TIRIO1 to CPs, SP1, or TIRIO2</li> <li>• Operation of the RO plant for treatment of marginally saline water on site</li> <li>• Continued pumping saline contact water from underground mine to TIRIO2</li> <li>• SETP upgrade installation at the WTC</li> </ul>
<b>2023</b>	<ul style="list-style-type: none"> <li>• Water management plan similar to Year 3</li> <li>• Channel 3 remediation work completed</li> <li>• Channel 2 outlet berm constructed</li> <li>• Waterline construction (AWAR KM 15 to 30)</li> </ul>
<b>2024</b>	<ul style="list-style-type: none"> <li>• Water management plan similar to Year 3</li> <li>• Waterline construction (continued, AWAR KM6 to 15)</li> <li>• Dewatering of B36</li> <li>• Fish out of B36, B37, B38, B60, B61, and B62</li> </ul>

Mine Year	Major Water Management Activities and Sequence
2025	<ul style="list-style-type: none"> <li>• Continued waterline construction</li> <li>• Construction of diffuser at Itivia Harbour for treated saline discharge</li> <li>• Pre-commissioning of the SETP-WTC</li> <li>• Construction of Channel 11, CP9 Thermal Berm, Berm 4</li> <li>• Construction of CP9 within the footprint of PUMP01 pit</li> <li>• Dewatering of B38, A8, J6, J7, A35, A37</li> <li>• Channel 1, 7 and 8 remediation work</li> <li>• Culverts installation/replacement</li> </ul>
2026 (Planned schedule)	<ul style="list-style-type: none"> <li>• Anticipated Waterline commissioning</li> <li>• Commissioning of CP9 within the footprint of PUMP01 pit</li> <li>• Anticipated SETP-WTC commissioning</li> <li>• Construction of Berm CP7 North, Berm CP8, CP8, Channel 13, and Channel 14</li> <li>• Dewatering of A6 and other F Zone lakes</li> <li>• Culverts – as required</li> </ul>
2027 (Planned schedule)	<ul style="list-style-type: none"> <li>• SETP-WTC discharge through waterline</li> <li>• Construction of TSF extension</li> <li>• Construction of Dikes D-A6</li> <li>• Dewatering lake B7</li> <li>• Construction of Berm CP7 West</li> <li>• Construction of Channel 15</li> <li>• Culverts – as required</li> </ul>
2028 (Planned schedule)	<ul style="list-style-type: none"> <li>• SETP-WTC discharge through waterline</li> <li>• Dewatering of lakes B5, B6, and B34</li> <li>• Construction of Channel 15</li> <li>• Construction of WRSF7</li> <li>• Construction of Sump F1</li> <li>• Culverts – as required</li> </ul>
2029 (Planned schedule)	<ul style="list-style-type: none"> <li>• SETP-WTC discharge through waterline</li> <li>• Construction of Dike D-B5North and D-B5South</li> <li>• Construction of CPD1 and CPD2</li> <li>• Construction of 18</li> <li>• Culverts – as required</li> </ul>
2030 (Planned schedule)	<ul style="list-style-type: none"> <li>• SETP-WTC discharge through waterline</li> <li>• Construction of Channel 12</li> <li>• Construction of Sump P5</li> <li>• Culverts – as required</li> </ul>
2031+ (Planned schedule)	<ul style="list-style-type: none"> <li>• SETP-WTC discharge through waterline</li> <li>• Start to fill the mined-out TIRI01 and TIRI02 with active freshwater pumping from Meliadine Lake</li> <li>• Stop pumping excess saline contact water from underground when underground mine is completed</li> <li>• Start natural flooding of Tiriganiaq Underground mine with groundwater seepage</li> <li>• Stop pumping water to process plant when the processing is completed</li> </ul>

#### 4.1.1 Pond Dewatering and Displacement

The initial dewatering at Lake H17 and Lake A54 was conducted in 2016 prior to constructing CP1 and CP5, respectively. The water from these ponds was pumped to Meliadine Lake through a temporarily installed diffuser.

Preparation for construction of CP4 facility required dewatering of the two shallow ponds B8 and B9 into CP1. Preparation for CP3 did not require dewatering as B28 contained insufficient volumes to dewater.

In Q3 2019, partial dewatering of Ponds H19 and H20 to the EWTP took place, following the advanced timeline for the construction of CP6 and WRSF3. Specifically, H19 was partially dewatered to facilitate construction of Berm CP6, while H20 was partially dewatered to allow the placement of waste rock and overburden within the drained lake basin. Detailed information regarding the CP6 design and subsurface thermal analysis can be found in the CP6 and Berm Design Report (Tetra Tech, 2020).

In Q3 2022, lakes and ponds A9, A38, A40, B33, and B33A were dewatered to allow for the continued mining within the final footprint of TIRI01, as authorized by DFO in a letter on April 20, 2022 (file 21-HCAA-02733). Water was pumped into the site water management collection ponds before being treated by the EWTP and discharged to Meliadine Lake. The final dewatering report was provided by Agnico Eagle to KivIA and DFO on October 21<sup>st</sup>, 2022.

In Q3 2024, dewatering of lake B36 and partial dewatering of lakes and ponds B37, B38, B60, B61 and B62 to the EWTP took place to allow mining within the Pump area. Dewatering and fish-out authorizations were granted by DFO (file 24-HCAA-00842). The final dewatering report was provided by Agnico Eagle to DFO on December 12<sup>th</sup>, 2024.

In Q3 2025, dewatering of lake A7, A8, A35, A37, and B38 took place to allow mining within the Pump area. Dewatering and fish-out were granted by DFO (file 24-HCAA-01238). The final dewatering report was provided by Agnico Eagle to DFO on December 15<sup>th</sup>, 2025.

As presented in Table 12, other waterbodies are planned to be dewatered to allow the construction of water management infrastructure and other developments of the mine plan. A total of 25 waterbodies were identified for potential dewatering under the 2024 Water Licence Amendment application. However, most of the volume of water planned to be dewatered is related to 6 lakes: A52, A6, A8, B5, B6, and B7. Table 13 summarizes the waterbodies dimensions and estimated dewatering timelines and volumes.

Dewatering of waterbodies may expose shoals composed of unconsolidated sediments, which may lead to local sedimentation within the impounded water. The introduction of sediments (TSS) into the water column will depend on the type of material exposed, material properties, slope gradient, prevailing weather conditions, dewatering timing and rate at which the waterbody is drawn down.

The quality of water pumped from each waterbody will be monitored daily to verify that it is acceptable for release to the receiving environment according to the Part D, Item 12 of the amended Water Licence

(see Water Quality and Flow Monitoring Plan, section 3.1.2). Non-compliant water will be pumped to CP1 for TSS removal at the EWTP-WTC before discharge to the receiving environment (see section 3.9.4.1 and 3.9.4.4 for more details on treatment and sludge disposal). The FEIS (Golder, 2014b) estimated that at base case for the site conditions, 60% of the total dewatered water would be suitable to direct discharge to the receiving environment. However, based on the uncertainties in TSS generation during dewatering, a more conservative estimate of 50% of the planned dewatering volume is assumed to require TSS treatment at the EWTP-WTC prior to discharge.

Table 11 describes the water management infrastructure that will be built within the footprint of the dewatered waterbodies and Table 13 presents the planned water management strategy for dewatered waterbodies; the annual report will capture updates on completed dewatering.

Among all planned dewatered waterbodies, only five (i.e., A8, A6, B5, J6, B34) will need to be included in the water management system and pumped to manage their water level. All other dewatered waterbodies that are not overlapped by infrastructure will naturally drain toward one of the aforementioned lakes. Dewatered waterbodies will be operated (pumped) to ensure sufficient storage for extreme events. Level in managed dewatered waterbodies will be lowered to ensure sufficient storage at freshet for extreme events without having to rely on pumping to CP1 to store the event water volume. Operating levels will be determined and dewatering of the waterbodies will be completed to allow partial (3:7) or full (7:7) storage of the drainage volume from a 1:100 wet year spring freshet.

**Table 13: Planned Lakes and Ponds Dewatering Schedule Inventory**

Pond/Lakes	Maximum Water Depth (m)	Average Water Depth (m)	Existing Pond Surface Area (m <sup>2</sup> )	Total Lake Volume (m <sup>3</sup> )	Planned Proportion of Lake Volume Dewatered (%)	Estimated Total Volume of Water Dewatered (m <sup>3</sup> )	50% of Volume of Water Dewatered (m <sup>3</sup> )	Completion schedule
A30*	1.2	0.2	22,523	1,288	20%	258	129	Q3 2026
A31*	2.4	0.4	16,734	9,657	20%	1,931	966	Q3 2026
A33*	0.3	0.1	7,814	310	20%	62	31	Q3 2026
A34*	0.2	0.1	2,374	97	20%	19	10	Q3 2026
A35*	0.1	0.0	2,282	17	100%	17	9	Completed
A37*	0.3	0.1	7,921	180	100%	180	90	Completed
A44*	0.3	0.1	7,022	225	20%	45	22	Q3 2026
A45*	0.3	0.1	14,939	453	20%	91	45	Q3 2026
A49*	0.6	0.2	4,673	438	20%	88	44	Q3 2026
A5*	0.9	0.2	18,299	704	100%	704	352	Partially Q3 2027
A50*	0.1	0.1	400	17	100%	17	8	Q3 2026
A51*	0.3	0.1	3,749	112	100%	112	56	Q3 2026
A52*	8.8	1.8	68,430	124,774	100%	124,774	62,387	Q3 2026
A53*	0.3	0.1	324	11	100%	11	5	Q3 2026
A6	4.4	1.5	537,847	780,527	100%	780,527	390,263	Q3 2026
A7	1.3	0.5	20,969	5,058	20%	1,012	506	Completed
A8	4.1	1.6	885,245	1,239,371	100%	1,239,371	619,685	Completed
B34*	4.7	0.6	38,844	21,773	20%	4,355	2,177	Q3 2028
B5	3.4	1.5	553,802	473,085	100%	473,085	236,543	Q3 2028
B6	3.7	1.4	113,203	138,994	20%	27,799	13,899	Q3 2028
B7	5.1	1.5	563,478	666,073	100%	666,073	333,037	Q3 2027
J6*	1.8	0.4	15,675	2025	1,871	100%	1,871	Completed

\*Waterbodies with no bathymetric data available, volumes are estimated from an extrapolation of the surrounding lake topography (Messenger et al., 2016)

#### **4.1.2 Underground Water Management**

The underground water management system is designed to prevent water from affecting the workings or production. The system contains a series of sumps (generally one at the access of each level) designed to capture groundwater inflows and runoff from mining operations (i.e., drilling), a clarification system, and a pumping system to redistribute the clarified saline contact water. Excess saline contact water is pumped to surface for management. Further details on the underground water management system are provided in the Groundwater Management Plan.

Beginning December 2018, the SWTP began treating groundwater to reduce stored saline contact water on site (See Section 3 for details). Furthermore, as part of the strategy to manage excess groundwater infiltration within the underground portion of the mine, Agnico Eagle received approval for marine discharge of saline water with the amended Project Certificate on February 26, 2019 (See Section 3.11 and Groundwater Management Plan for details). A new amendment (Amendment 002 of the NIRB Project Certificate No. 006) was received on March 2<sup>nd</sup>, 2022, allowing the discharge of treated saline water through a waterline.

#### **4.1.3 Water Management for Haul Road**

A network of roads provides access to infrastructure at the Mine. The majority of the roadways servicing the mining area are located so that drainage is directed by berms, channels and culverts towards CP1, CP2, CP3, CP4, CP5, and CP6. Detailed information about water management on roads is described in the Meliadine Mine Roads Management Plan.

#### **4.1.4 Water Management for Landfarm and Landfill**

Any water that accumulates at the onsite Landfarm is pumped through an oil-water separator prior to discharge into CP1. Additional details about Landfarm water management are described in the Landfarm Management Plan.

Leachate from the Landfill is anticipated to be non-hazardous and non-toxic due to the controls put in place on the materials accepted for deposition in the Landfill. Annual Landfill operations involve clearing of snow prior to spring melt. In the event there is leachate from the Landfill due to periods of heavy rainfall or spring freshet, the runoff will be collected, controlled and treated, if necessary, and sent to CP1, as per the Landfill Management Plan.

Internal runoff and drainage from the Landfill will gradually seep through the northeast perimeter berm towards pond H13. As per the Technical Memorandum for the Operation Landfill (Stage 4) Berm Raise Summary (Agnico Eagle, 2024c), the Operation Landfill (Stage 4) utilizes a pumping system to facilitate the removal of water ponded against the perimeter berm if the rate of seepage is insufficient for water removal. Water pumped from the Landfill is directed to Pond H13, which is the current location seepage from the Landfill flows towards. H13 is immediately upstream of Culvert 2, which is upstream of Channel 1 and ultimately CP1. Water collected in CP1 is treated at the EWTP-WTC prior to being discharged to Meliadine Lake.

Monitoring of seepage from the Landfill (between the Landfill and Pond H13) or water pumped from the

Landfill and directed to Pond H13 is conducted as per the Water Licence at compliance monitoring station MEL-24.

#### **4.1.5 Water Management for Emulsion Plant Area**

Freshwater is trucked to the emulsion plant and used for manufacturing emulsion as well as for washing vehicles. Water within the emulsion plant is re-used when feasible, and excess water is collected and disposed of on site (i.e., STP) or stored and shipped south as hazmat.

#### **4.1.6 Water Management for the Wash Bay**

Water used in the Wash Bay is re-used when feasible and excess water is treated with an oil-water separator to reduce or remove hydrocarbons. Treated water is moved to CP1 or the surface saline ponds, depending on *in situ* specific conductivity applied to approximate TDS concentration. Solid waste from the treatment process is removed and disposed of appropriately (Landfarm, hazmat, or underground).

### **4.2 Freshwater and Sewage Management**

Additional freshwater usage and sewage management is described in the following sections.

#### **4.2.1 Freshwater Management**

Major freshwater usages on site include potable use, fire suppression, make-up water for the mill, and other operational needs, such as drilling and paste production for backfill. Freshwater is sourced from Meliadine Lake through a freshwater intake and pump system. For dust suppression, water is sourced from the freshwater intake system, ponded water located along the AWAR, or small ponds proximal to the road. Surface contact water from collection ponds may be used for dust suppression on areas that are within the site surface contact water system catchment.

Freshwater is pumped through an overland pipeline to potable water storage tanks and a fire water suppression tank. Under the Amended Licence, 1,100,296 m<sup>3</sup>/year of freshwater is permitted during operation phase. Additionally, 8,676,481 m<sup>3</sup> of freshwater is permitted per year to fill the mined-out open pits during the mine closure. These quantities are inclusive of water needs for dust suppression.

The maximum design flow rate for the potable water for the main camp and accommodations (kitchen, laundry) is 216 m<sup>3</sup> per day. There is an onsite Potable Water Treatment System (Section 3.9.1). Treated potable water is piped to areas in the service complex and other facilities requiring potable water. Table 15 provides the updated freshwater consumption needs during the mine Operation phase in comparison to needs assessed for the 2014 FEIS and for the 2021 Water Licence.

**Table 14: Freshwater Consumption for Meliadine Mine**

V19

Items	2014 FEIS		Amended Water Licence (2021)	Amended Water Licence (2024)	2026 Meliadine Water Licence Amendment
	provided in m <sup>3</sup> /h	converted to m <sup>3</sup> /yr	m <sup>3</sup> /yr	m <sup>3</sup> /yr	m <sup>3</sup> /yr
Camp Use	5.67	49,669	50,000	73,000	83,000
Truck Shop-Washbay	8.5	74,460	9,636	365	365
Paste Plant	5.5	48,180	105,120	157,000	157,000
Mill	107.2	939,072	424,860	652,000	652,000
Drilling Water	N/A	N/A	1,460	730	730
Dust Control	18	45,000	24,168	24,168	24,168
Emulsion Plant	1.6	14,016	1,520	1,950	1,950
Underground Washbay	50	438,000	2,200	2,200	2,200
Discovery Installation				5,500	5,500
Pit Production	1.5	12,000	N/A		
Sub-total	198	1,620,397	618,964	916,913	916,913
<b>Contingency</b>	<b>25%</b>		<b>20%</b>	<b>20%</b>	<b>20%</b>
<b>Total</b>	<b>247.5</b>	<b>2,168,100</b>	<b>742,757</b>	<b>1,100,296</b>	<b>1,112,296</b>

#### 4.2.2 Sewage Management

Sewage collected from the camp and MSB facilities is pumped to the STP. The objective of the STP is to treat sewage to an acceptable level for discharge to CP1 via a treated sewage water discharge pipeline. The STP is housed in a prefabricated (modular) structure, located at south-east of the service complex at the Industrial Pad, as shown in Figure 2. The system is designed to treat a maximum daily flow of 299 m<sup>3</sup> per day.

The STP for the camp facilities is designed to meet appropriate guidelines for wastewater discharge (Agnico Eagle, 2020c). Details regarding STP specifications and operation can be found in the Operation & Maintenance Manual Sewage Treatment Plant (Agnico Eagle, 2021a).

#### 4.2.3 Process Water Management

Process water is required in the mill for ore processing and is primarily sourced from Meliadine Lake through the freshwater intake system. As per the Licence, reclaim of surface contact water for use at the Mill is maximized to the greatest practical extent.

### 4.3 Meliadine Lake Diffuser Effluent Flow Rates

The EWTP is designed to meet the minimum required rate of 12,000 m<sup>3</sup>/d per the design requirements of dike D-CP1 (Tetra Tech, 2016b). While the EWTP equipment has an operational range up to 28,000 m<sup>3</sup>/d, the current system is configured to operate a maximum discharge rate of 18,000 m<sup>3</sup>/d to prevent overpressuring in the HDPE line that conveys water from the EWTP to the diffuser.

The pump does not operate continuously at the maximum rate. The rate of discharge is determined during the open water season to meet the design criteria and performance objectives of D-CP1. The anticipated amount of effluent discharge each month per year can be found in the Water Balance and Water Quality Model (WBWQM) results in section 3.2 of the Annual Report. Details on the WBWQM setup and methods are discussed in section 5 of this document.

Discharge to Meliadine Lake is expected to be required on an annual basis. However, discharge of surface contact water through the waterline to Itivia Harbour will be conducted in accordance with the Adaptive Management Plan to minimize discharge to Meliadine Lake once the waterline is operational (Agnico Eagle, 2024a).

The anticipated amount of effluent requiring discharge over each year is based on the Water Balance and Water Quality Model (WBWQM). Updates to the WBWQM are conducted at a minimum of annually and results can be found in the most recent submission of the Annual Report.

## SECTION 5 • WATER BALANCE

### 5.1 Site Water Balance Model

The site-wide water balance model is set-up to represent the interaction of the local climatic regime with the mine plan and water management plan, and based on these interactions, to predict the volumes of various water types (i.e., non-contact, surface contact and saline contact) requiring management, treatment and discharge to the receiving environment (Lorax 2026).

**Table 15: Evolution of Site Water Balance Model**

Year	Reference	Update Summary
2014	Tetra-Tech, 2014	Initial model for evaluating contact water infrastructure and pumping needs for Life of Mine and Closure. Included CP1, CP3, CP4, CP5, CP6, Tiriganiaq Open Pit and Tiriganiaq Underground
2020	Golder, 2020b	Update for 2020 Water Licence Amendment; inclusion of CP2
2021	Lorax, 2021	New Water Balance Water Quality Model (WBWQM) using the GoldSim modelling platform
2024	Lorax, 2024	Updated WBWQM for 2024 Water Licence Amendment
2025	Lorax, 2025	Updated WBWQM for 2025 Modification Application (inclusion of CP8, storage of water in mined-out Pits, and Pump Underground)
2026	Lorax, 2026	Updated for Water Licence Amendment Operational Update (life of mine to 2036, deeper PUMP02 Underground)

V19

As per Part E, Item 13 of the Water Licence, the WBWQM is updated at minimum once every year to reflect operating conditions and results are provided in the Annual Report. In previous years, two GoldSim models were employed to inform mine and water management planning:

1. The Operational WBWQM, based on the GoldSim model version created by Lorax (2021), and updated continuously, with the last update made in January 2026.
2. The WLA WBWQM, based on the updated GoldSim model version created by Lorax (2026) in support of the Water License Amendment Operational Update application.

V19

As mine development progresses, the alignment between these models has progressed to the point where the Operational WBWQM is used to predict mine contact water volumes and loads, discharges and closure phase conditions in the conjoined flooded pits. The Operational WBWQM underwent an extensive validation and recalibration in 2025 to better represent the measured contact and non-contact water volumes and concentrations in all collection and saline ponds, as well as the influence of dust deposition

on downwind collection pond and lake concentrations of parameters of concern. Henceforth, the Operational WBWQM is referred to as the WBWQM.

## 5.2 Model Setup

The WBWQM is built in the GoldSim v15 software platform and is set-up to run on a daily time-step. The primary modelling objective is the prediction of water and solute load transfers within the mine site, and to the receiving environment. The WBWQM is configured to predict the transfer of water and solute mass (loadings) from mined and non-contact areas into the relevant water management facilities. All mixing is assumed to occur instantly, and all mass is conserved throughout the model (i.e., no attenuation is applied to any of the parameters that are tracked). The water balance model is run with a variable climate record that is scaled to represent the projected impacts of climate change under the RCP4.5 emissions scenario.

## 5.3 Water Management Assumptions and Inputs

Details of the surface contact water management strategy are described in section 4, while the detailed saline groundwater management can be found in the Groundwater Management Plan (GWMP). Notable updates to the water management assumptions encoded in the WBWQM are as follows:

- The waterline is assumed to begin discharging treated saline water to Itivia Harbour during the open water season in 2027;
- The PUMP02 pit will be used as a saline water sump once mining is complete in mid-2026 and will be online to capture saline runoff from the underground WRSF in 2026;
- The WES02 pit will also be used as a saline water reservoir once mining is complete in 2026;
- The WES03 pit will serve as an intermediate surface contact water reservoir, with CP3, CP4, CP5, CP8, and STP discharge routed here, prior to discharge to Itivia Harbour via the Waterline;
- Once dewatered, Lake B7 will be utilized as a surge storage reservoir for surface contact water (CP7) during high flow periods and,
- CP8 will be constructed to capture TSF runoff and interflow along the northwestern boundary to prevent these flows from reporting to B7, and instead, route them to WES03.

The general flow network used in the WBWQM for the current state of the mine (2025 model version) is shown in **Error! Reference source not found..** The general flow network at the end of the life-of-mine in the WBWQM is shown in **Error! Reference source not found..**

### 5.3.1 Pond Pumping Rates

The WQWBM model assumes pumping rates between CP2, CP3, CP4, CP5, CP6, and WES03 (beginning in 2027) to CP1, as well as pumping rates between saline ponds such as SP1, Tiri 02, and WES02 (beginning in 2027) are based on maximum designed pumping rates for each facility while factoring in historic pumping data. Pumping demand is assumed to occur continuously throughout the open water season, from the start of June to the end of October. Historical quantities of recorded pumping rates between surface ponds since 2018 are applied to the model.

### 5.3.2 Discharge to Itivia Harbour

Currently, saline water from the underground mine is stored in Tiriganiaq Open Pit 2 (TIRI02), and as such, no discharge quantities are applied to the model until the waterline commissioning. Only previous discharges of saline water from SP4 to Itivia Harbour by trucking are applied to the WBWQM for the historical period where these discharges occurred.

The waterline operation presented in the WLA WBWQM assumed a discharge rate of 20,000 m<sup>3</sup>/day beginning in 2025 with a seasonal discharge window from June 20<sup>th</sup> to September 29<sup>th</sup>. However, construction and commissioning of the waterline will continue in 2026 and thus this assumption has been revised such that discharge via the waterline to Itivia Harbour begins in 2027.

### 5.3.3 Discharge to Meliadine Lake

Currently, treated surface contact water effluent from the EWTP is discharged to Meliadine Lake via a diffuser. While EWTP equipment has an operational range up to 28,000 m<sup>3</sup>/d, the current system is configured to operate a maximum discharge rate of 18,000 m<sup>3</sup>/d to prevent over-pressuring in the HDPE line that conveys water from the EWTP to the diffuser. The allowable discharge period assumed in the model spans June 1 to October 7 of each year.

For both models, the guiding principle for discharge of site contact water (saline and surface) is to minimize the volumes discharged to Meliadine Lake to the extent practicable and maximize the discharge of surface contact water to Itivia Harbour via the waterline, while still effectively managing the site saline contact water balance as outlined in the Adaptive Management Plan for Water Management (Agnico Eagle, 2024a). However, the models assume surface contact water discharge to Meliadine Lake will take priority if the volume of water in CP1 reaches 30% of the maximum operating volume of the facility (i.e., the upstream toe elevation of the dike), or if the volume of water in CP1 is above the maximum freeze-up volume between the window of October 1<sup>st</sup> to October 7<sup>th</sup>. These conditions allow for minimization of surface contact water to Meliadine Lake while respecting the design criteria of D-CP1 and other infrastructure.

### 5.3.4 Underground Mine Dewatering

Groundwater inflows represent the largest portion of water pumped from the Tiriganiaq underground mine to TIRI02. Predictions of future underground inflow rates to the underground mine are generated using a 3D groundwater model (WSP-Golder, 2022). The model was updated in early 2026 to consider updates to the underground Tiriganiaq and Pump mine development and to better reflect inflows estimated using measurements collected within the mine for the 2018-2025 period. A moisture content percentage is applied to a mine plan forecast of the monthly tonnes of ore and waste rock removed from the underground mine to represent entrained moisture being removed from the mine. A fixed quantity of freshwater used for paste line flushing is assumed per month. Additionally, a percentage of bleed-water from paste backfill is assumed and applied to forecasted tonnes of paste backfill.

The updated WBWQM considers that saline contact water originating from the underground mine will be pumped to saline storage on the surface (TIRI02) prior to 2026 and routed to the WES02 pit in 2027 and onwards.

More details are provided in the Ground Water Management Plan.

### 5.3.5 Consumptive Freshwater Uses

Consumptive freshwater uses (e.g., paste plant, potable water, mill makeup, dust control, etc.) are supplied by withdrawal from Meliadine Lake. They are not included as direct inputs to the water balance models, as this additional water is already incorporated in various components of the mine water balance, such as sewage treatment plant discharge, seepage from placed tailings and paste backfill bleed-water reporting to underground workings.

### 5.3.6 Sewage Treatment Plant Discharge

Both models consider that the sewage treatment plant (STP) is rated for a treatment rate of 299 m<sup>3</sup>/day, and discharges to CP1. Estimated water use per person is 250 L/day, and camp capacity will be 900 persons, which equates to a total inflow to (and thus treated discharge rates from) the STP of 225 m<sup>3</sup>/day, routed to CP1. During the active closure phase, the STP operation is considered for 6 months of the year (May to October), with a camp capacity of 75 persons.

### 5.3.7 Climate Inputs

The climate input series spans a 100-year period from 2020 to 2119, and consists of daily minimum, mean and maximum air temperature and precipitation values derived from the Rankin Inlet climate station, and adjusted to reflect future climate projections under the RCP4.5 representative concentration pathway (OKC, 2022a; 2022b). This station was shown to be representative of climate conditions as measured by the Meliadine climate station and given the much longer and more complete record at Rankin Inlet, this dataset was used to represent climate conditions at the Meliadine site (OKC, 2022a; 2022b). Mean annual precipitation in the RCP4.5 input series over the operations period is 412.3 mm, and on a monthly average basis, precipitation ranges from a minimum of approximately 17 mm in February to a maximum of 59 mm in September (Table 16). The average annual air temperature is -10.4°C, with minimum and maximum mean temperatures of -30°C in January and 11°C in July, respectively. Both models are based on the same logic for climate series implementation.

**Table 16: Average monthly climate conditions at Meliadine for the Operations Phase.**

Parameter	Jan	Feb	Mar	Apr	May	Jun	Jul	Aug	Sep	Oct	Nov	Dec	Annual
Min. Temp. (°C)	-33.9	-33.7	-29.2	-20.4	-8.9	0.7	6.4	6.4	1.4	-7.1	-20.7	-29.1	-33.9
Avg. Temp. (°C)	-30.3	-30.1	-24.9	-15.9	-5.6	4.4	10.8	9.8	3.9	-4.5	-16.9	-25.3	-10.4
Max. Temp. (°C)	-26.7	-26.4	-20.6	-11.4	-2.3	8.1	15.1	13.2	6.4	-1.8	-13	-21.6	15.1
Precipitation (mm)	17.5	17.1	24.3	27	25.8	30	46.8	46	58.8	53	36.4	29.5	412.3

Parameter	Jan	Feb	Mar	Apr	May	Jun	Jul	Aug	Sep	Oct	Nov	Dec	Annual
Rain (mm)	0	0	0	0.3	3.8	25.4	47	46.2	56.9	16.3	0.4	0.3	196.5
% Rain	0%	0%	0%	1%	15%	84%	100%	100%	94%	32%	1%	1%	36%
Snow (mm)	17.7	16.8	24.6	27	21.3	4.8	0	0	3.6	34.6	36.3	29.7	216.4
% Snow	100%	100%	100%	99%	85%	16%	0%	0%	6%	68%	99%	99%	64%

### 5.3.8 Waterbodies Dewatering

The WBWQM accounts for lake dewatering necessary to accommodate construction of mine infrastructure the Meliadine Mine FEIS footprint. Lakes and ponds are dewatered in the year prior to the associated mine infrastructure coming online. Based on operational experience gained through the lake dewatering campaign in 2025, the upper 70% of lake volume is expected to contain low levels of TSS, and thus will be discharged to the receiving environment without treatment. The lower 30% of each lake (by volume) is expected to contain higher levels of TSS, and therefore these volumes will be treated for TSS prior to discharge.

### 5.3.9 Water Quality Model Component

The water quality model component of the WBWQM is built upon the architecture of the water balance model, with water quality signatures assigned to non-contact (undisturbed) areas and to specific disturbed mine areas (e.g., infrastructure, stockpiles, tailing facilities, underground mine, open pits). Water quality inputs to the water quality component of the WBWQM, or source terms, are based on either a set of assumptions that reflect empirical observations from the operating mine site, data collected at analogue mine sites, or the results of various geochemical and metallurgical tests that have been undertaken to provide a basis for assigning likely future water quality associated with specific mine components. Conceptually, modelled flows and associated source terms are combined in the GoldSim platform to simulate predicted water quality estimates at key locations across the mine site (e.g., ponds, pit lakes) and the two receiving environment nodes (Itivia Harbour and Meliadine Lake) throughout the phases of the Meliadine Mine.

Both WBWQM are set-up to run on a daily time-step for the three main phases of mine life: Operations, the Active Closure period where pit flooding with Meliadine Lake water is under way; and, Post-Closure. Concentrations of water quality parameters required by Type A Water Licence 2AM-MEL1631 Part F, Item 3 are modelled for all mine water management ponds and sumps, that receive runoff from the different mine areas. Water quality outputs are compared on a daily time-step with the in-situ measured water quality values as a validation step for the historical period, or future predictions are aggregated on a monthly time-step and are screened against required water quality objectives (Water License Part E Section 13).

## 5.4 Water Balance Model Methods

This section summarizes the approach, assumptions, conceptual model and inputs used to construct the site-wide water balance model.

### 5.4.1 Approach and Assumptions

The site-wide water balance model (WBM) is set-up to represent the interaction of the local climatic regime with the mine plan and WMP, and based on these interactions, to predict the volumes of various water types (i.e., non-contact, surface contact and saline contact) requiring management, treatment and discharge to the receiving environment. Given the potential for upset conditions to occur on sub-monthly time scales (i.e., high magnitude rainfall events, rapid freshet), and the operational necessity of managing mine contact waters on a daily basis, the WBM is set-up to run on a daily time-step.

### 5.4.2 Sub-Catchment Delineation

To generate water volume estimates from precipitation inputs, the delineation of both the natural and mine-altered watershed areas was necessary for modelling the locations of interest. The catchment areas by year from the beginning of the mine operation until now are presented in the Annual Report Appendix 05 – Table 1. Sub-catchment nomenclature was based on the water management feature that each mine component reports to via gravity drainage. For example, ‘CP1-Natural’ refers to the non-contact area drainage that reports to the CP1. The catchment areas by year used for the model projecting the mine operation and closure according to the Amended Water Licence WBWQM are presented in the Annual Report Appendix 05 – Table 1.

### 5.4.3 Watershed Model

The WBM is based on a distributed catchment approach, where meteoric inputs (i.e., rainfall and snowmelt) are modified by runoff coefficients calibrated for natural and mine altered areas are applied to generate runoff.

As part of the model calibration update undertaken in 2025, the foundational watershed model used to predict runoff from natural (undisturbed) and disturbed areas was updated. The watershed model was previously conceptualized as a three-reservoir system, comprised of quickflow (surface flow), shallow interflow, and baseflows (Lorax 2022). The availability of additional site monitoring data prompted a reassessment of the watershed model conceptualization and calibration. As part of this effort, the GR4J watershed model (Perrin et al., 2003; Perrin et al., 2007) was used to generate daily discharge volumes for natural and undisturbed areas. Snow accumulation and melt is calculated using the Cemaneige snowpack model (Valéry et al., 2014), which has two adjustable parameters: the degree day factor, which converts heat energy as a function of air temperature into snowmelt in mm/day; and, the snowpack inertia factor, which tracks the amount of heat input required to initiate melt (i.e., cold content).

Surface runoff computed for natural ground using the GR4J model is adjusted using representative runoff coefficients for the altered mine areas. Future estimates of surface runoff, infiltration, interflow and basal

seepage from the TSF and WRSFs were modelled by OKC (OKC 2022a; 2022b) for the RCP4.5 climate change scenario and provided at a daily time-step for direct input to the WBWQM. For some specific mine perturbed areas, only the quick flow component is used, and the natural runoff coefficient is adapted/calibrated to the characteristics of the perturbed surface.

#### **5.4.4 Potential Evapotranspiration**

The Hargreaves-Samani method (Hargreaves and Samani 1985) was used to develop estimates of potential evaporation, using the long-term daily record of minimum, average and maximum daily temperatures, as well as factors related to potential solar insolation (e.g., latitude [63.08°] and day of year).

#### **5.4.5 Lake Ice Growth and Ice Melt**

A temperature-based ice algorithm was implemented to model cryo-concentration in CP1. Lake ice melt is handled by the Bilello equation (Bilello, 1980; Lotsari et al. 2019). The lake ice growth algorithm is not applied to any other facilities than CP1, including saline storage facilities (i.e., Tiri 02, SP1, SP6).

#### **5.4.6 Closure and Post-Closure Assumptions**

The last year of mining in the Meliadine Mine will occur in 2036. The Active Closure phase commences the following year (2037) and is expected to last for 7 years. The following assumptions specific to this phase are included in the WQWBM:

Any saline waste rock from the UG mine remaining on surface will be used within backfill in the underground workings.

Ore pads, plant site, facilities areas and laydown areas will be reclaimed.

Non-PAG waste rock covers will be progressively placed on the TSF and Discovery WRSF to limit the interaction of the active layer with the underlying tailings and waste rock, respectively.

Pits will be filled with collected surface contact water, gravity drainage from the catchments surrounding the pits, and supplementary flows pumped from Meliadine Lake.

All Operation phase water management infrastructure will remain in place for this period (pumping, treatment, discharge pipelines to Meliadine Lake and Itivia Harbour), no discharges to Meliadine Lake are planned.

All remaining saline contact water will be pumped from WES02 to the underground void spaces from October 2037 onwards. CP7 will be actively refilled by pumping water from Meliadine Lake during the open water season of 2037 (384,000 m<sup>3</sup>).

Any contact water or saline water in excess of the available capacity in the underground mine will be treated by the SETP and discharged to Itivia Harbour in 2037.

The post-Closure phase begins in 2044, and is characterized by the following activities:

- All water management infrastructure (i.e., channels, berms, ponds) will be decommissioned and pre-existing drainage patterns restored to the extent practical once surface contact water meets the relevant water quality criteria.
- All contact flows revert to pre-mining drainage patterns where possible.
- Mine area discharges reporting to the nearest downstream lake are assumed to fully mix in that lake.

## 5.5 Waterbody Inventory

Table 17 presents the waterbodies that are impacted by the Mine activities in Watersheds A, B, H and J. Lakes that are planned to be impacted by future mining activities are illustrated on **Error! Reference source not found.** and detailed in **Error! Reference source not found.**, section 4.1.1.

**Table 17: Inventory of Waterbodies Impacted by Mining Activities.**

Watershed	Waterbody	Maximum Lake Water Depth, m	Total Area (ha)	Water Volume (m <sup>3</sup> )	Notes
A	A9	N/A	0.18	-	Pond removed for TIRI01 slope stability
	A10	0.67	0.26	-	Ponds removed by development of TIRI01
	A11	0.45	0.40	-	
	A12	0.87	0.47	-	Pond drained due to construction of Channel 5
	A13	0.30	0.26	-	
	A17	0.30	0.16	-	Covered by WRSF 1
	A38	N/A	0.05	-	Pond removed for TIRI01 slope stability
	A39	0.48	0.12	-	Pond removed by development of TIRI02
	A40				Pond removed for TIRI01 slope stability
	A54	1.3	5.99	34,545	Dewatered for CP5
	A58	0.50	0.43	-	Covered by Laydown Area
B	B8	0.8	1.43	-	As part of CP4/Berm-CP4
	B9	1.40	0.64	-	Dewatered for CP4
	B10	0.8	0.33	-	Pond removed by development of TIRI01
	B28	N/A	0.45	-	As part of CP3/D-CP3
	B33				Pond removed for TIRI01 slope stability
	B33A				Pond removed for TIRI01 slope stability
H	H6	0.58	0.75	-	As part of CP1
	H7	0.67	0.11	-	
	H8	0.59	0.38	-	Partially covered by WRSF2 and haul road
	H9	0.40	0.42	-	Partially covered by OP2
	H10	0.11	0.10	-	Partially covered by OP2, drained due to construction of Channel1
	H11	0.27	0.28	-	
	H12	0.81	0.97	-	Drained due to construction of Channel1 and partially covered by OP2

Watershed	Waterbody	Maximum Lake Water Depth, m	Total Area (ha)	Water Volume (m <sup>3</sup> )	Notes
J	H13	1.04	3.49	-	Drained due to construction of Channel1 and partially covered by industrial pad
	H14A	0.37	0.15	-	Covered by industrial pad
	H15D	0.30	0.15	-	Partially covered by TSF
	H15G	0.40	0.38	-	
	H17	1.70	15.8	195,700	Dewatered for CP1
	H17A	1.50	0.13	1,365	Dewatered for Meliadine esker
	H17B	1.50	0.69	10,350	Dewatered for Meliadine esker
	H17C	1.50	0.23	3,450	Dewatered for Meliadine esker
	H18	0.67	0.74	-	Covered by OP2
	H19	1.40	2.91	16,431	Dewatered for CP6
	H20	1.60	9.58	90,307	Covered by WRSF3
J	J6				Flow regime impacted by partial pad covering
"-" indicates that data not available or not applicable <span style="display: inline-block; width: 15px; height: 10px; background-color: #cccccc; border: 1px solid black; margin-right: 5px;"></span> Ponds drained <span style="display: inline-block; width: 15px; height: 10px; background-color: #d9ead3; border: 1px solid black; margin-left: 20px; margin-right: 5px;"></span> Ponds dewatered					

## SECTION 6 • WATER QUALITY

---

Water quality monitoring is an important part of the Water Management Plan to verify the predicted water quality trends, conduct adaptive management should differing trends be observed, and to ensure all water quality limits at discharge points are met (i.e., effluent to Meliadine Lake and Itivia Harbour). Water quality results and water transfers (i.e., origin, destination, rate) at the Mine are monitored and documented pursuant to the Licence.

Water quality monitoring was initiated at the pre-development stage, continued through construction into operations, and will continue into closure and post-closure. Monitoring occurs at four levels:

1. Regulated discharge monitoring that occurs at monitoring points specified in the Licence or MDMER regulations.
2. Verification monitoring that is undertaken for operational and water management purposes by Agnico Eagle.
3. General monitoring that is commonly included in the Licence, specifying what is to be monitored according to a schedule. General monitoring is subject to change as directed by an Inspector, or by the Licensee, subject to approval by the NWB.
4. Event Monitoring (EM) that addresses the site-specific monitoring that is required following any accidental release. The EM program is designed to verify whether contamination of the surface soil and/or any nearby receiving environment and active zone has occurred as a result of an accidental release of a hazardous material or contaminated water. A “release” may be caused by spills, including unidentified seepage or emergencies.

Water quality monitoring include quality assurance/quality control procedures that are implemented as per current Quality Assurance/Quality Control Plan. Appendix D of the Meliadine Mine Water Quality and Flow Monitoring Plan provides details of the Monitoring Program Stations on site and at Itivia. Figure 8 and Figure 9 depict the Monitoring Program Stations on site and at Itivia.

### 6.1 Summary of Regulatory Guidelines

Water quality results are compared to MDMER criteria and effluent quality limits listed in the Licence. Water quality pertaining to MEL-14 will be compliant to Part F, Item 3 of the Licence prior to discharging to Meliadine Lake. All surface runoff and/or discharge from drainage management systems associated with the Mine, including laydown areas and All-Weather Access Road, where flow may directly or indirectly enter a Water body, shall not exceed the Effluent quality limits listed in Part D, Item 18 of the Licence. Furthermore, all waters from natural water body dewatering activities shall be directed to Meliadine Lake and shall not exceed the Effluent quality limits listed in Part D, Item 12.



Post-closure discharge water quality will be compared to Canadian Council of Ministers of the Environment Water Quality Guidelines (CCME-WQG) guidelines or the Meliadine Site Specific Water Quality Objectives (SSWQO) developed for aluminum, fluoride, and iron (Golder 2013a, 2013b, 2014). The Meliadine SSWQO criteria were developed as a conservative protection measure for the aquatic receiving environment and were developed by Golder (2013a, 2014) to assess whether waste rock consisted of a deleterious substance according to Environment Canada (2013). The outcome of the assessment was that Meliadine waste rock is not a deleterious substance (Environment Canada 2014).

## **6.2 Water Quality Monitoring - Licence Amendment**

As a component of the Emergency Amendment (2020) and in support of the Water Licence Amendment Application (Amendment No. 1, 2021), additional regulated discharge monitoring was carried out in 2020, as described in the Meliadine Mine Water Quality Management and Optimization Plan (WQ- MOP). The purpose of the WQ-MOP sampling program was both to assess conditions experienced in Meliadine Lake during the 2020 discharge event and for the application of a science-based framework to support the determination of acceptable effluent quality conditions (EQCs) and SSWQOs. Further information regarding the WQ-MOP, including specifics of the 2020 sampling program, application of monitoring data, adaptive management measures and thresholds for the development of SSWQOs for chloride can be found in the Meliadine Mine Water Quality Management and Optimization Plan Progress Update (Golder 2021).

## **6.3 Water Quality Modelling and Forecasts**

Water quality for past and current (2025) operation of the mine is simulated using the version of the WBWQM, whereas updated water quality predictions for future operations (2026+), closure and post-closure periods are conducted using the WBWQM (Lorax 2025). Concentrations of water quality parameters required by the Type A Water Licence 2AM-MEL1631 under Part F, Item 3 are modelled for all mine water management ponds and sumps.

As per the amended Water Licence, the water quality forecast will be updated annually. Future updates to the water quality forecast will be provided in the Annual Report.

## **6.4 Post-Closure**

As per the 2014 Final Environmental Impact Statement (FEIS) water quality model provided in Agnico Eagle (2015b), long-term, post-closure water quality in the flooded open pit lakes are anticipated to meet MDMER limits and CCME-WQG for the protection of aquatic life or the SSWQO developed for the Mine for total dissolved solids, arsenic, , fluoride, and iron. Water quality is predicted to improve in Closure when mining activities cease, and pit lakes are flooded with Meliadine Lake water. Detailed water quality predictions at Post-Closure are included in the Meliadine Mine Water Balance and Water Quality Model Technical Report (Lorax 2026).



## SECTION 7 • WATER MANAGEMENT DURING CLOSURE

The detailed Mine closure and reclamation activities are provided in the Meliadine Mine Interim Closure and Reclamation Plan. Water management during closure and reclamation will involve controlled flooding of the open pits using a combination of excess surface water and freshwater from Meliadine Lake, as well as the natural flooding of the Underground Mine workings with groundwater inflows (groundwater seepage) and may include the transfer of any saline water remaining on surface. Flooding of open pits with excess surface water will be such that water quality is to meet the closure objectives as set out in the Meliadine Mine Interim Closure and Reclamation Plan. Water management infrastructure will remain operational until monitoring confirms that water quality is suitable for discharge to the environment without further treatment. Once water quality meets the discharge criteria, the water management systems will be decommissioned to allow the water to naturally flow to the environment.

The key water management activities during Mine closure are summarized in Table 18. Figure 10 illustrate the water management layout after Mine closure. Additional details for the activities are described in the following sections.

**Table 18: Key Water Management Activities during Mine Closure**

Phase	Figure	Key Water Management Activities and Sequence
Active Closure (2037 to 2043)	5	<ul style="list-style-type: none"> <li>Flooding of mined out pits</li> <li>Continue to collect and manage the contact water in collection ponds</li> <li>Continue to pump the contact water in CP1 to EWTP, if required, for treatment before being discharged to the outside environment</li> <li>Remove non-essential site infrastructure</li> <li>Pump the underflow sludge water from EWTP to CP1</li> <li>Continue natural flooding of Tiriganiaq and Pump Underground Mine and the transfer of remaining surface saline water (if needed)</li> <li>Remove Meliadine Lake pumping system</li> </ul>
Post-Closure (2044+)	10	<ul style="list-style-type: none"> <li>Treat the contact water until water quality meets direct discharge criteria and then decommission the water management system</li> <li>Continue natural flooding of Tiriganiaq and Pump Underground</li> <li>Breach water retention dikes and thermal berms once water quality monitoring results meet discharge criteria to allow water to naturally flow to outside environment</li> <li>Remove culverts and breach remaining water retention berms (pending the demonstration of acceptable water quality)</li> </ul>

### 7.1 Mine Flooding

Water management during closure and reclamation will involve controlled flooding of the open pits using a combination of excess surface water and freshwater from Meliadine Lake. Flooding of open pits with excess surface water will be such that water quality is to meet the closure objectives set out in the Meliadine Mine Interim Closure and Reclamation Plan. Transfer of all remaining surface saline water in

the open pits to the Underground Mine workings will be completed in the first 1-2 years of the Active Closure phase.

Refilling of the mine out pits is anticipated to take seven years, with pumping of Meliadine Lake water at a maximum of 8.7 Mm<sup>3</sup>/year (Lorax 2026). Discharge of any remaining surface contact water or saline water that cannot be stored in the underground mine will be treated and discharged via the waterline to Itivia Harbour. The water quality model results indicated that water quality in the flooded pits will meet the discharge criteria and post closure treatment will not be required. The water quality within the pits will be monitored during flooding to verify the prediction of the water quality model. The information will be used to develop a strategy to minimize contamination of the regional surface water system.

More details are provided in the Meliadine Mine Water Balance and Water Quality Model Technical Report (Lorax 2026).

### 7.3 Collection Ponds, Dikes and Berms

The collection ponds, dikes and berms will remain in place to collect the surface runoff water and seepage from the Mine until the water quality meets discharge criteria. Once the water quality meets discharge criteria, dikes/berms will be breached to allow runoff to follow natural (topographically induced) flow paths. Dikes/berms breaching will involve the removal of a portion of the dikes to a minimum depth of 1 m below average water level or back to original ground levels. Consideration will be given to breach staging, with the above water portions of the dike/berm in the breach area removed during winter periods, when there will be little surface water flow, thereby minimizing the potential release of sediments to the neighbouring waterbodies. The remainder of the breach would be conducted during the open water season following freshet. Turbidity curtains would be deployed to minimize any potential sediment release to surface water.

### 7.4 Channels and Sumps

Once monitoring results have indicated that contact water conveyed in channels and sumps meets acceptable water quality, the infrastructure will be graded and/or surface treated according to site-specific conditions to minimize wind-blown dust and erosion from surface runoff, if required. This closure activity is intended to enhance site area development for re-colonization by native plants and wildlife habitat.

---

## REFERENCES

---

- Agnico Eagle Mines Limited (Agnico Eagle), 2014. Final Environmental Impact Statement Document Package – Meliadine Gold Project, Nunavut, Submitted to Nunavut Impact Review Board.
- Agnico Eagle. 2015a. Meliadine Gold Project: Mine Plan. Version 1. 6513-MPS-10. April 2015.
- Agnico Eagle. 2015b. Meliadine Gold Project: Water Management Plan. Version 1. 6513-MPS-11. April 2015.
- Agnico Eagle. 2017a. Final Spill Report, Tank Release April 8, 2017. June 2017.
- Agnico Eagle. 2018. Design Report, Saline Water Treatment Plant. Document number: 6515-E-132- 013-105-REP-035, August 2018.
- Agnico Eagle. 2019a. As Built Report, Saline Water Treatment Plant (SWTP), July 2019.
- Agnico Eagle. 2019b. Meliadine Gold Project. Roads Management Plan. Version 8. 6513-MPS-03. December 2019.
- Agnico Eagle. 2019c. Meliadine Gold Project. Construction Summary (As-built) Report for Berm 2, Channel3, Pond CP3, and Berm CP3. Version A. 6515-695-230-REP-001. October 2019.
- Agnico Eagle. 2019d. Meliadine Gold Project. Construction Summary (As-built) Report for Channel4, Pond CP4, and Berm CP4. Version A. 6515-695-230-REP-002. December 2019.
- Agnico Eagle, 2020a. Operational and Maintenance Manual – Freshwater Treatment Plant Upgrade. Version R0. 6526-461-132-REP-001. June 2020.
- Agnico Eagle 2020b. Design Report – Saline Effluent Treatment Plant (SETP) Upgrade. Version R2. 6526-680-132-REP-001. August 2020.
- Agnico Eagle, 2020c. Design Report – Sewage Treatment Plant (STP) Upgrade. Version R0. 6526-460- 132-REP-002. July 2020.
- Agnico Eagle. 2020d. Meliadine Gold Project. Construction Summary (As-built) Report for Collection Pond 6 (CP6) and Berm CP6. 6526-695-230-REP-002. August 2020.
- Agnico Eagle, 2021a. Operation & Maintenance Manual (OMM) – Sewage Treatment Plant Upgrade. Version 5. 6526-460-132-REP-001. March 2021.
- Agnico Eagle, 2021b. As-Built Report – Building for Water Treatment Complex (WTC). Version R0. 6526-694-132-REP-002. February 2021.

- Agnico Eagle, 2021c. Operation & Maintenance Manual – Effluent Water Treatment Plant (EWTP).Version 2. January 2021.
- Agnico Eagle, 2021d. Design Report Saline Effluent Treatment Plant (SETP-WTC). December 2021.
- Agnico Eagle. 2022a. Meliadine Gold Project: Landfarm Management Plan. Version 4. April 2022.
- Agnico Eagle. 2022b. Meliadine Gold Project: Landfill and Waste Management Plan. Version 8. April 2022.
- Agnico Eagle, 2022c. Meliadine Gold Project. Quality Assurance/Quality Control Plan. Version 4. April 2022.
- Agnico Eagle, 2024a. Adaptive Management Plan for Water Management. Version 9. January 2024. Agnico Eagle, 2024b. Fish Offsetting Plan Version. January 2024.
- Agnico Eagle, 2024c. Technical Memorandum: Operations Landfill (Stage 4) Berm Raise Summary, Meliadine Mine, Nunavut. March 2024.
- Environment Canada. 2013. Guidelines for the Assessment of Alternatives for Mine Waste Disposal. Ottawa, ON, Canada. June 2013.
- Environment Canada. 2014. Electronic mail communication from Environment Canada to Agnico Eagle. Subject: Assessment of Meliadine Waste Rock. May 6, 2014.
- Golder (Golder Associated Ltd.). 2009. Assess of completeness of geotechnical data for feasibility design Tiriganiaq open pit. Submitted to Comaplex Minerals Corp., 26 May 2009, Doc. 008 Rev. 0
- Golder. 2012a. SD 7-2 Aquatic Baseline Studies- Meliadine Gold Project, Nunavut, Canada. A Technical Report Submitted to Agnico Eagle Mines Ltd. by Golder Associates, September 19, 2012.
- Golder. 2012b. SD 6-1 Permafrost Thermal Regime Baseline Studies- Meliadine Gold Project, Nunavut, Canada. A Technical Report Submitted to Agnico Eagle Mines Ltd. by Golder Associates, September 25, 2012.
- Golder. 2012c. Tailings Storage Facility Preliminary Design – Meliadine Gold Project, Nunavut. A Draft Report Submitted to Agnico Eagle Mines Ltd. by Golder, August 16, 2012. INAC, 1992. Guidelines for ARD Prediction in the North. Department of Indian Affairs and Northern Development, Northern Mine Environment Neutral Drainage Studies No.1, Prepared by Steffen, Robertson and Kirsten (B.C.) Inc.
- Golder. 2013a. Site specific Water Quality Objectives (SSWQO) Assessment – Meliadine Gold Project, Nunavut. Document 371. Report to Agnico-Eagle Mines Ltd. February 22, 2013. 57 p.
- Golder. 2013b. Appendix 7.2-B, Hydrogeological Modelling, Meliadine Gold Project, Nunavut. Technical Report Submitted to Agnico Eagle Mines Ltd. Reference No. Doc 335-101370076, Jan. 16, 2013.

- Golder. 2014a. SD 2-6 Surface Water Management Plan – Meliadine Gold Project, Nunavut. Doc 32-1314280007 Ver. 0. April 2014.
- Golder. 2014b. Assessment of Site Specific Exposure and Toxicity Modifying Factors on Aluminum Toxicity and Validation of Non-Deleterious Nature of All Parameters of Potential Concern in Waste Rock Leachate – Meliadine Gold Project, Nunavut. Document 440. 2014. Report to Agnico- Eagle Mines Ltd. March 14, 2014. 7 p.
- Golder. 2015. Meliadine Gold Project. Appendix E: Near-Field Modelling and Diffuser Design. Report Number: Doc 493-1405283 Ver. 0. March 2015.
- Golder. 2020a. Meliadine Gold Project. Water Quality Management and Optimization Plan (WQ-MOP) Progress Update: Phase 3 - Finalize Meliadine Mine Effluent Discharge Benchmarks for TDS. 19132390-751-RPT-Rev3. July 2020.
- Golder. 2020b. Meliadine Gold Project. Meliadine Site Water Balance and Water Quality Model. Type A 2AM-MEL1631 Water Licence Amendment. 20144940-779-RPT-Rev1. July 2020.
- Golder, 2021. Water Quality Management and Optimization Plan Progress Update Rev4b. Phase 3: Meliadine Mine Effluent Discharge Benchmarks for Total Dissolved Solids. 21480734-751-RPT-Rev4b. August 2021.
- Government of Canada. 2002. Metal and Diamond Mining Effluent Regulations. SOR/2002-222; last amended on June 10, 2021.
- Lorax Environmental Services Ltd Ltd. (Lorax). 2022. Meliadine Extension: Water Balance and Water Quality Model Technical Report. Prepared for Agnico Eagle Mines Ltd, by Lorax Environmental Services, February 2022.
- Lorax Environmental Services Ltd. (Lorax). 2025. Meliadine Mine Modification Water Balance and Water Quality Model-Technical Report issued to Agnico Eagle Mines Limited. June 2025.
- Lorax Environmental Services Ltd. (Lorax). 2026. Meliadine Mine Modification Water Balance and Water Quality Model-Technical Report issued to Agnico Eagle Mines Limited. April 2026.
- Messenger, M. L., Lehner, B., Grill, G., Nedeva, I., & Schmitt, O. (2016). Estimating the volume and age of water stored in global lakes using a geo-statistical approach. *Nature Communications*, 7(1), 13603. <https://doi.org/10.1038/ncomms13603>
- Nunavut Impact Review Board (NIRB). 2019. NIRB Meliadine Gold Mine Project Certificate [NO.: 006] Amendment. February 26, 2019.
- Nunavut Water Board (NWB). 2021. Amended Water Licence: No: 2AM-MEL1631. May 13, 2021.

- Perrin, C., Michel, C., and Andréassian, V. (2003). Improvement of a parsimonious model for streamflow simulation. *J. Hydrology*. 279(1-4). 275-289. [https://doi.org/10.1016/S0022-1694\(03\)00225-7](https://doi.org/10.1016/S0022-1694(03)00225-7)
- Perrin, C., Oudin, L., Andréassian, V., Rojas-Serna, C., Michel, C. and Mathevet, T. (2007). Impact of limited streamflow data on the efficiency and the parameters of rainfall-runoff models. *Hydrological Sciences*: 51(1).
- Valéry, A., Andréassian, V., and Perrin, C. (2014). ‘As simple as possible but not simpler’: What is useful in a temperature-based snow-accounting routine? Part 2 – Sensitivity analysis of the Cemaneige snow accounting routine on 380 catchments. *J. Hydrology* <http://dx.doi.org/10.1016/>
- SNC Lavalin Inc. 2020. Assessment of Water Balance and Water Quality Forecast around pond CP1 at Meliadine, Memorandum. Submitted as Attachment 03 in response to technical comments for the Meliadine Type A (2AM-MEL1631) Water Licence Amendment Application. November 2020.
- SNC Lavalin Inc. 2022. Meliadine Interim Closure and Reclamation Plan – Update 2020, Final report. Snowden. 2008. Tiriganiaq gold deposit, Nunavut – resource update. Submitted to Comaplex Minerals Corp. January 2008.
- Tetra Tech EBA. 2014. Tailings, Waste and Water Management for Feasibility Level Study, Meliadine Project, Nunavut. File: E14103188-01. December 2014.
- Tetra Tech EBA. 2015. Summary of Water Balance Key Assumptions and Results, Meliadine Gold Project. Technical Memorandum Submitted to Agnico Eagle Mines Ltd. by Tetra Tech EBA, October 2015.
- Tetra Tech EBA. 2016. Meliadine Lake Diffuser Design Progress Report for Discussion. September 20, 2016. File: E14103230-01 Task 007.
- Tetra Tech. 2017. Construction Summary Report for EWTP, Pumping Stations, Pipelines and Diffuser. September 2018. 6515-E-132-005-132-REP-014.
- Tetra Tech. 2018a. Design Report for CP3, CP4, CP Berms, Berm2, Channel3, and Channel4, Meliadine Project, Nunavut. June 2018. File: ENG.EARC03076-02, Document number: 6526- 695-100-REP-001.
- Tetra Tech. 2018b. Construction Summary (As-Built) Report Effluent Water Treatment Plant, Pumping Stations, Pipelines, And Diffuser, Meliadine Gold Project, NU. September 2018. Project number: 28920, Document number: 6515-E-132-007-132-REP-014.
- Tetra Tech. 2020a. Design Report for CP6 and CP6 Berm, Meliadine Project, Nunavut. January 24, 2020. File: ENG.EARC03140-06, Document number: 6526-695-100-REP-001.
- Tetra Tech. 2020b. Technical memo for prefeasibility level design of WRSF3 with extended footprint and associated water management infrastructure. June 2020. File: 704-ENG.EARC3206-01. July 2020.

- Tetra Tech. 2020c. Meliadine Lake Updated 3-D Modelling of the Discharge Assessment. November 2020. File: ENG.ACLE03008-05.
- Tetra Tech. 2022. Design Report for Effluent Water Treatment Plant, Pumping Stations, Pipelines & Associated Berm, and Diffuser. June 2022. File: 6515-E-132-005-132-REP-009.
- Tetra Tech. 2022. Construction Summary (As-built) Report for CP2 Pond, CP2 Berm, Channel9, and Channel10. October 2022. File: 704-ENG.EARC03140-28.
- Tetra Tech. 2024. Prefeasibility Level Design of Water Management Infrastructures for Meliadine Mine. January 2024. File: 704-ENG.EARC03193-04.
- WSP Golder. 2022. Updated Hydrogeology Modelling Meliadine Extension. 22513890-941-R Rev.B. Prepared for Agnico Eagle Mines Ltd. By Golder Associates Ltd. July 2022.
- WSP. 2024a. Updated Groundwater Modelling for Tiriganiaq Underground. Ref No. 22513890-947-R-RevA-GW. March 2024.
- WSP. 2024b. Updated Hydrogeology Modelling Meliadine Mine. WSP Doc. CA0020476.6818-MEL2024\_004-R-Rev0, January 2024.
- WSP. 2026. Meliadine Project – Updated Groundwater Modelling For Tiriganiaq And Pump Undergrounds. Project No. CA0042236.1659-MEL2026\_11-TM-RevA. March 2026.

FIGURES

Figure 1: General Mine Site Location Plan

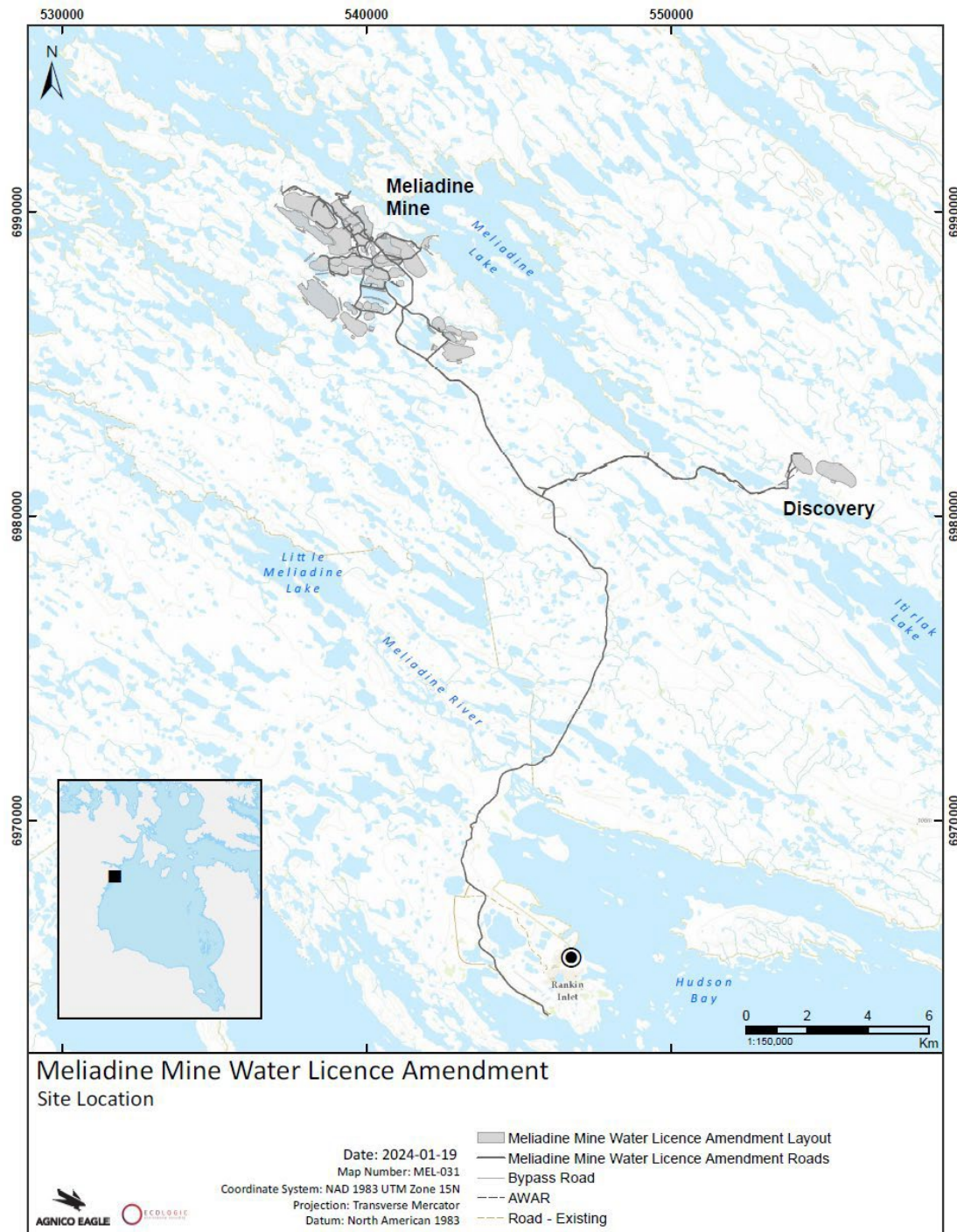
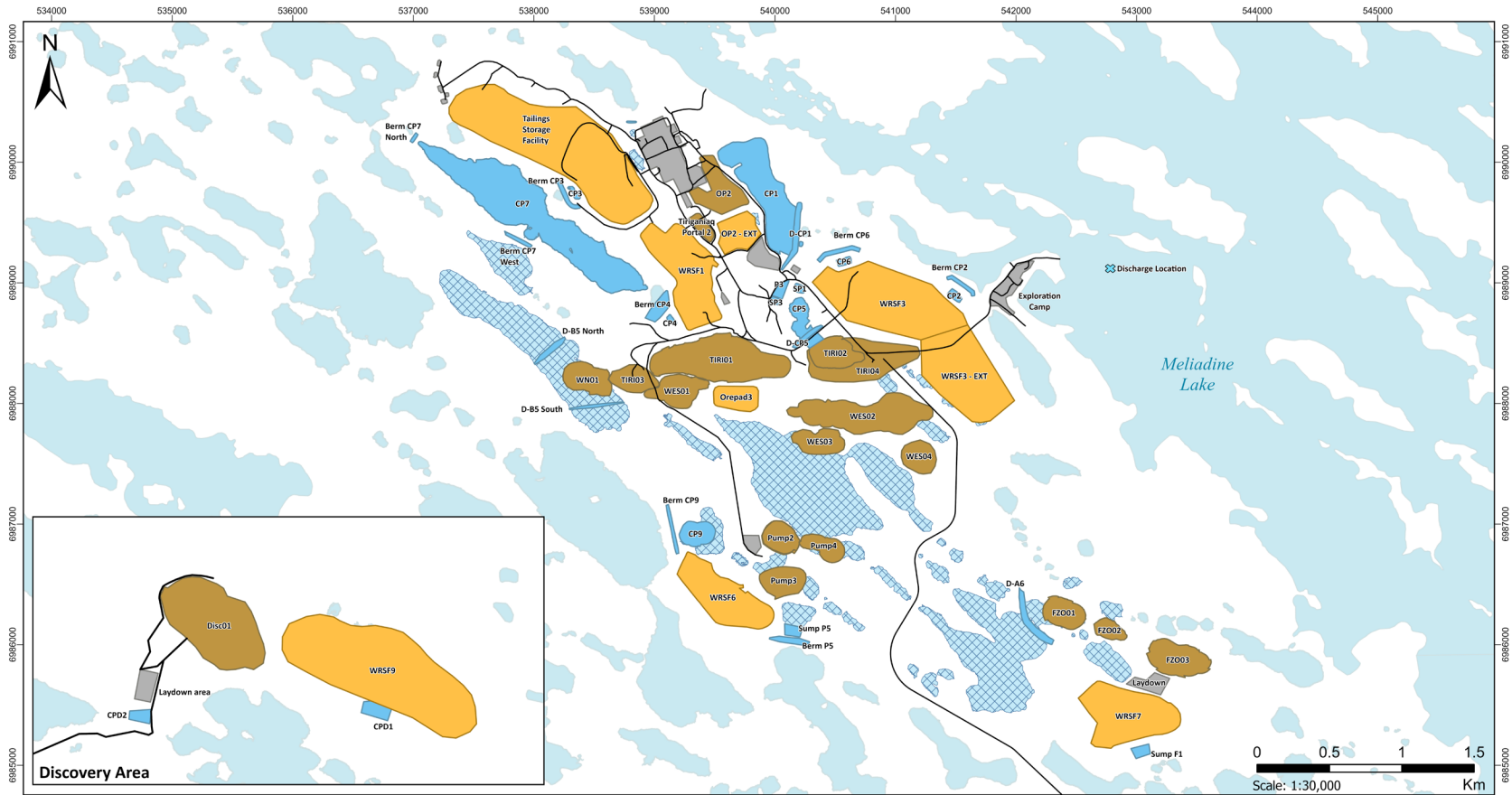

Figure 2: General Mine Site Plan Layout



Legend	
	Facilities
	Mining
	Storage
	Roads
	Water Management
	Managed Waterbodies
	Waterbodies

<b>Meliadine Mine Water Licence</b>										
Name: NAD 1983 UTM Zone 15N Projection: Mercator Auxiliary Sphere										
Map Units: Meter Authority: EPSG		<table border="1"> <tr> <td>Project Lead</td> <td>2018-01-04</td> </tr> <tr> <td>Map Author</td> <td>2018-01-04</td> </tr> <tr> <td>Map Reviewer</td> <td>2018-01-04</td> </tr> <tr> <td>Map Approver</td> <td>2018-01-04</td> </tr> </table>	Project Lead	2018-01-04	Map Author	2018-01-04	Map Reviewer	2018-01-04	Map Approver	2018-01-04
Project Lead	2018-01-04									
Map Author	2018-01-04									
Map Reviewer	2018-01-04									
Map Approver	2018-01-04									



**Figure 4: Location and Design of Saline Pond 4 (SP4) within Tiriganiaq Pit 1**

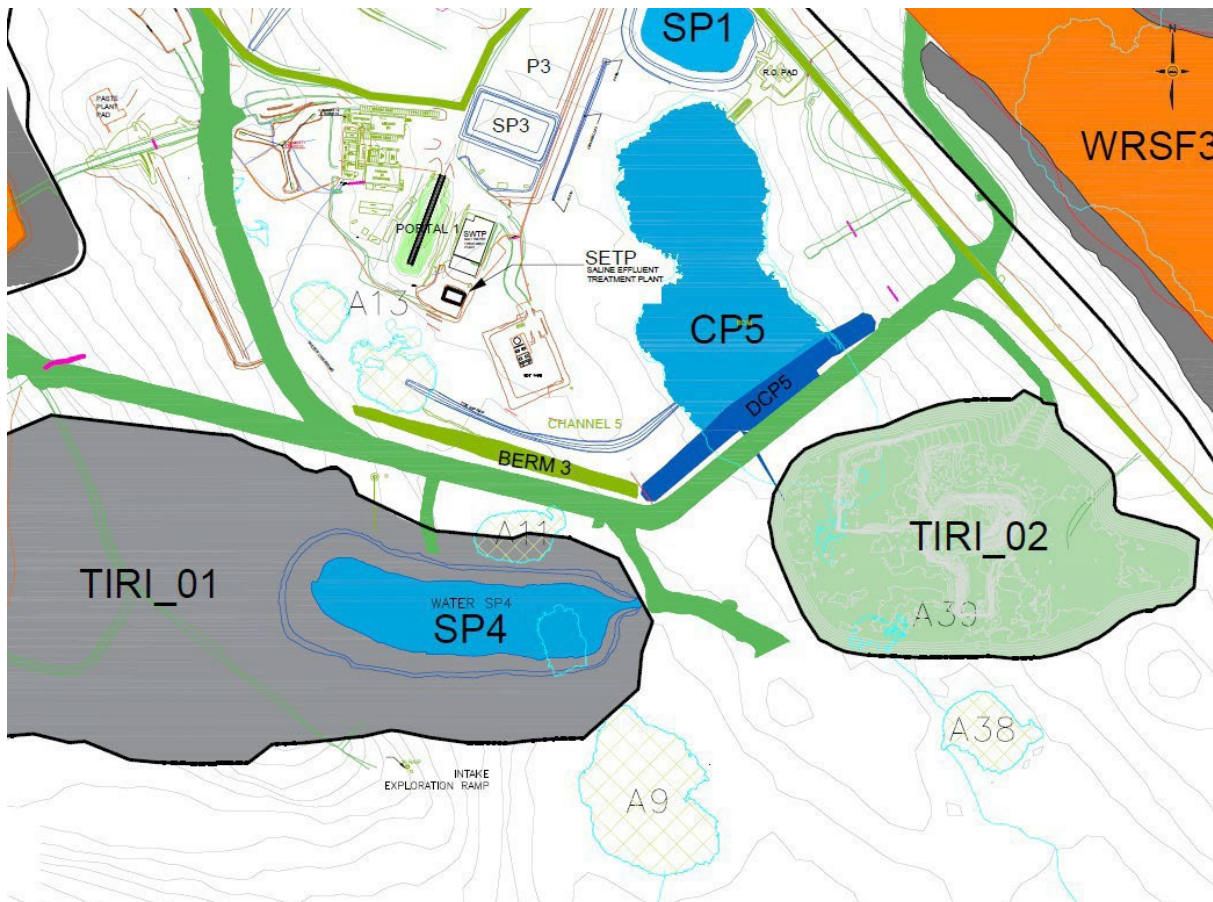
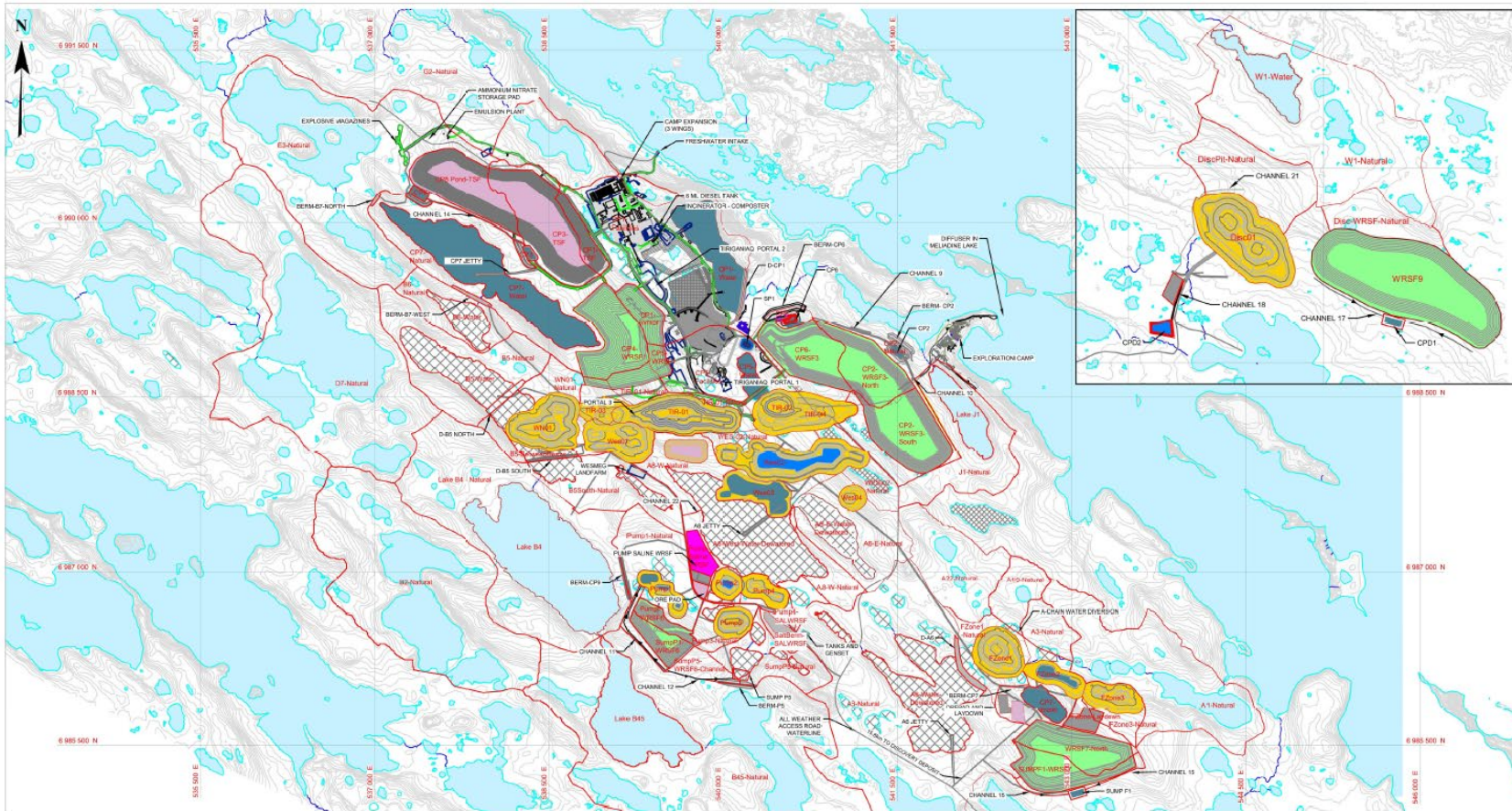
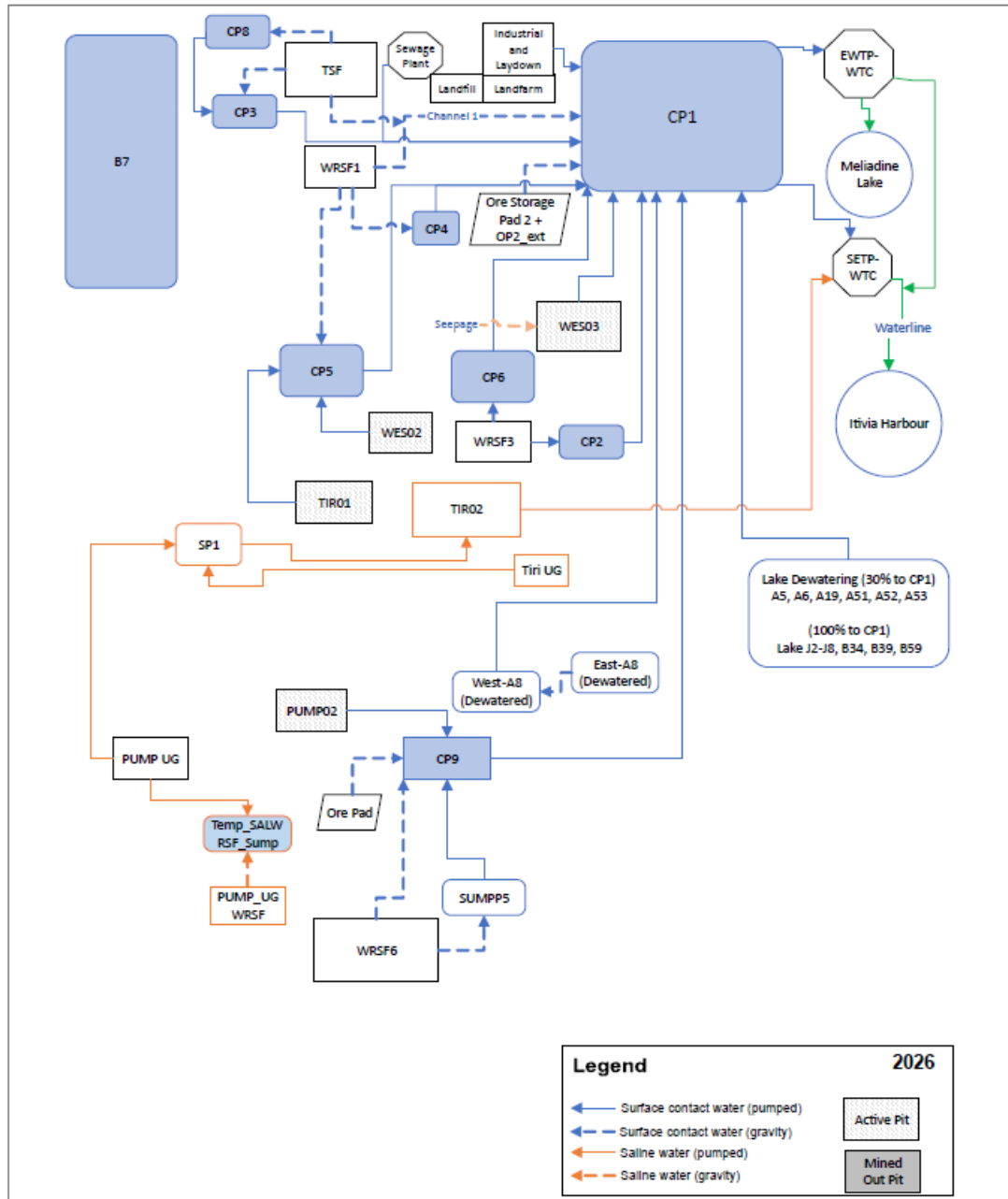

Figure 5: Mine Site Layout at 2036



<b>LEGEND</b> WATER-BALANCE DATUM MAJOR AND MINOR CONTOURS EXISTING GROUND ROAD ROAD TIE ROAD CREST HYDRO LINE PIPE LINE DIVERSION CHANNEL CONTACT WATER POND SALINE POND WATER DEWATERED APPROVED DIFFUSER VENT BASES OPEN PITS COMPLETED OPEN PITS IN PROGRESS TAILINGS STORAGE FACILITY IN PROGRESS WASTE ROCK STORAGE FACILITY COMPLETED	DATE SAVED: Apr 01, 2026 DRAWN BY: DM REVIEWED: SJ VERSION: 1	CLIENT:  	PROJECT: <b>Meliadine Mine WB/WQM</b> TITLE: Meliadine Mine Water Balance Layout - EOM - 2036 PROJECT #: A667-5 FIGURE: A1.11
	(Empty space for additional legend items or notes)	(Empty space for additional client information)	(Empty space for additional project information)

Figure 6: Conceptual Site Water Management Flow Diagram for the Site



DATE SAVED: Mar 02, 2009 DRAWN BY: DM REVIEWED: SJ VERSION: 1	 	PROJECT: <b>Meliadine Mine: 2026 Operational Update</b>	
		TITLE: Water Management Flow Diagram - 2026	
		PROJECT#: A867-5	FIGURE: B.1.1

**Figure 7: Conceptual Site Water Management Flow Diagram as Planned at the End of the Life of Mine**

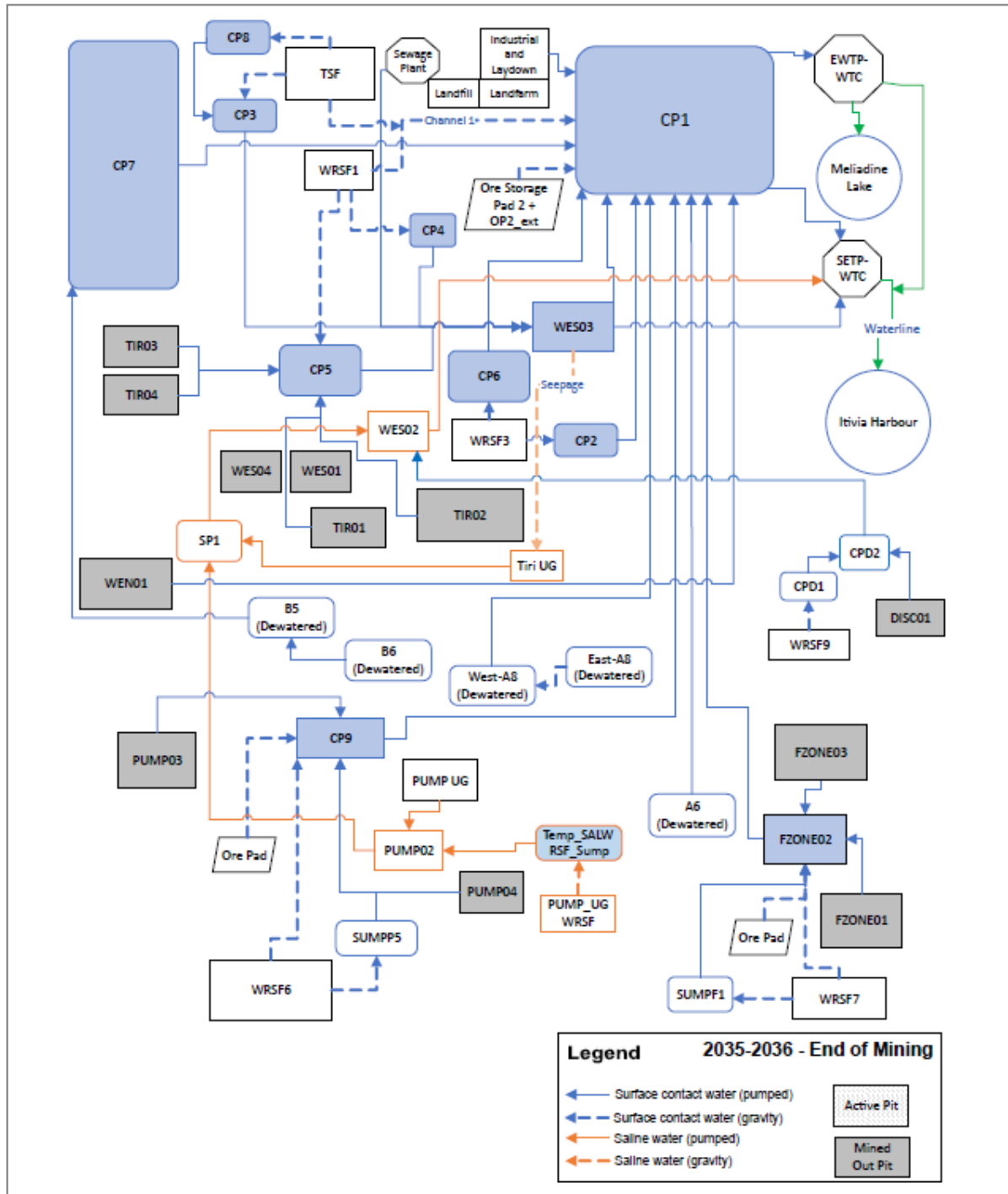
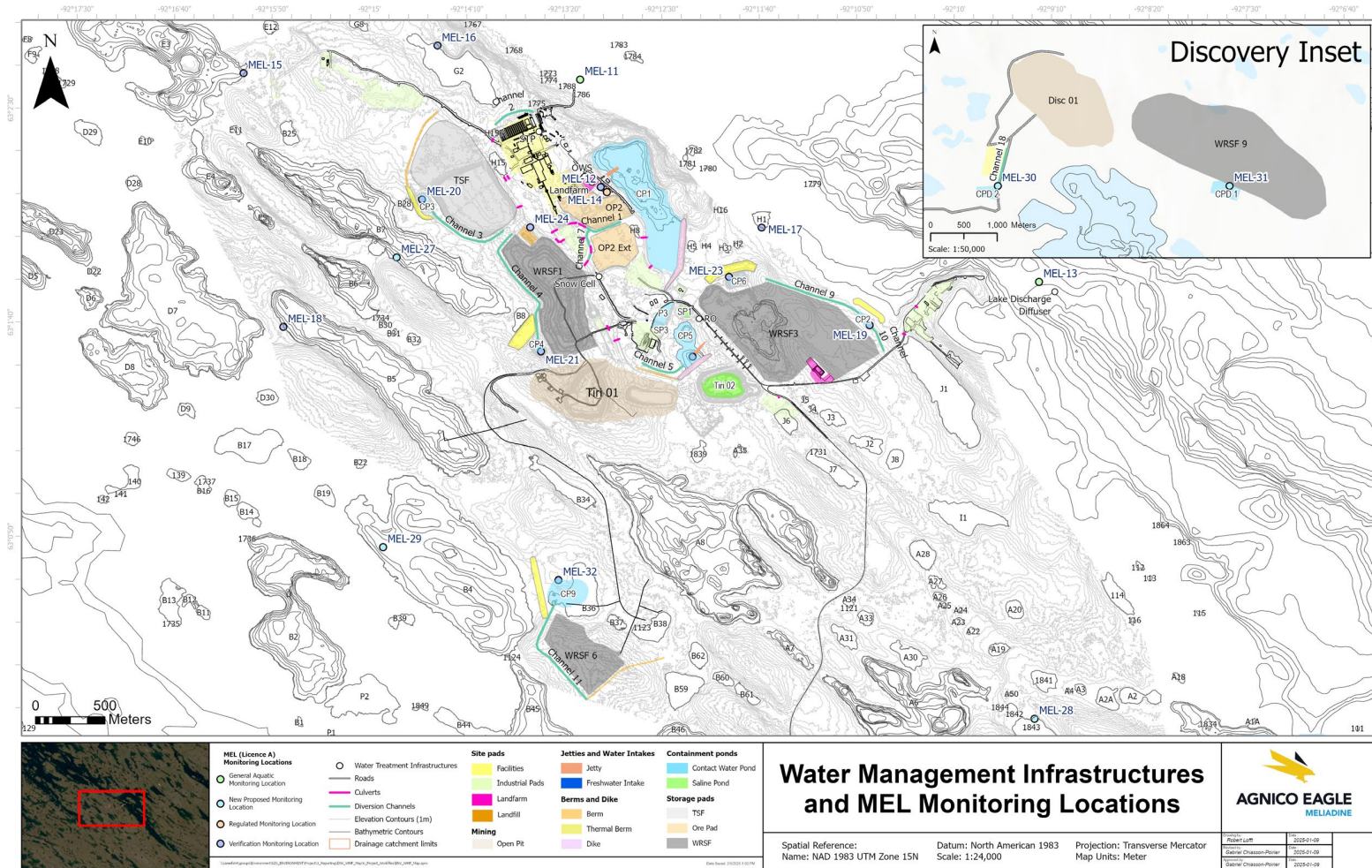

Figure 8: Water Quality Monitoring Locations on Site



**Figure 9: Water Quality Monitoring Locations at Itivia**

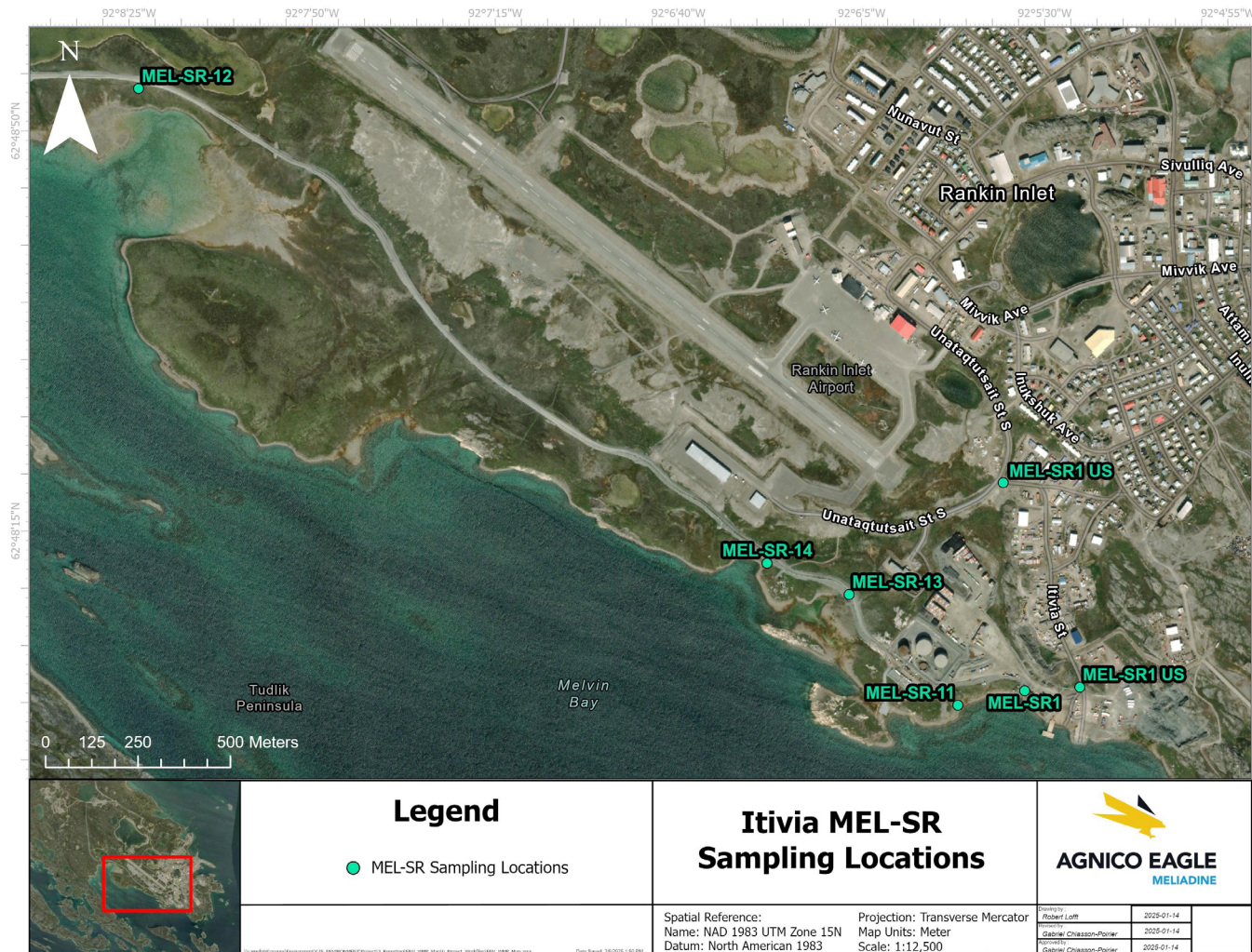
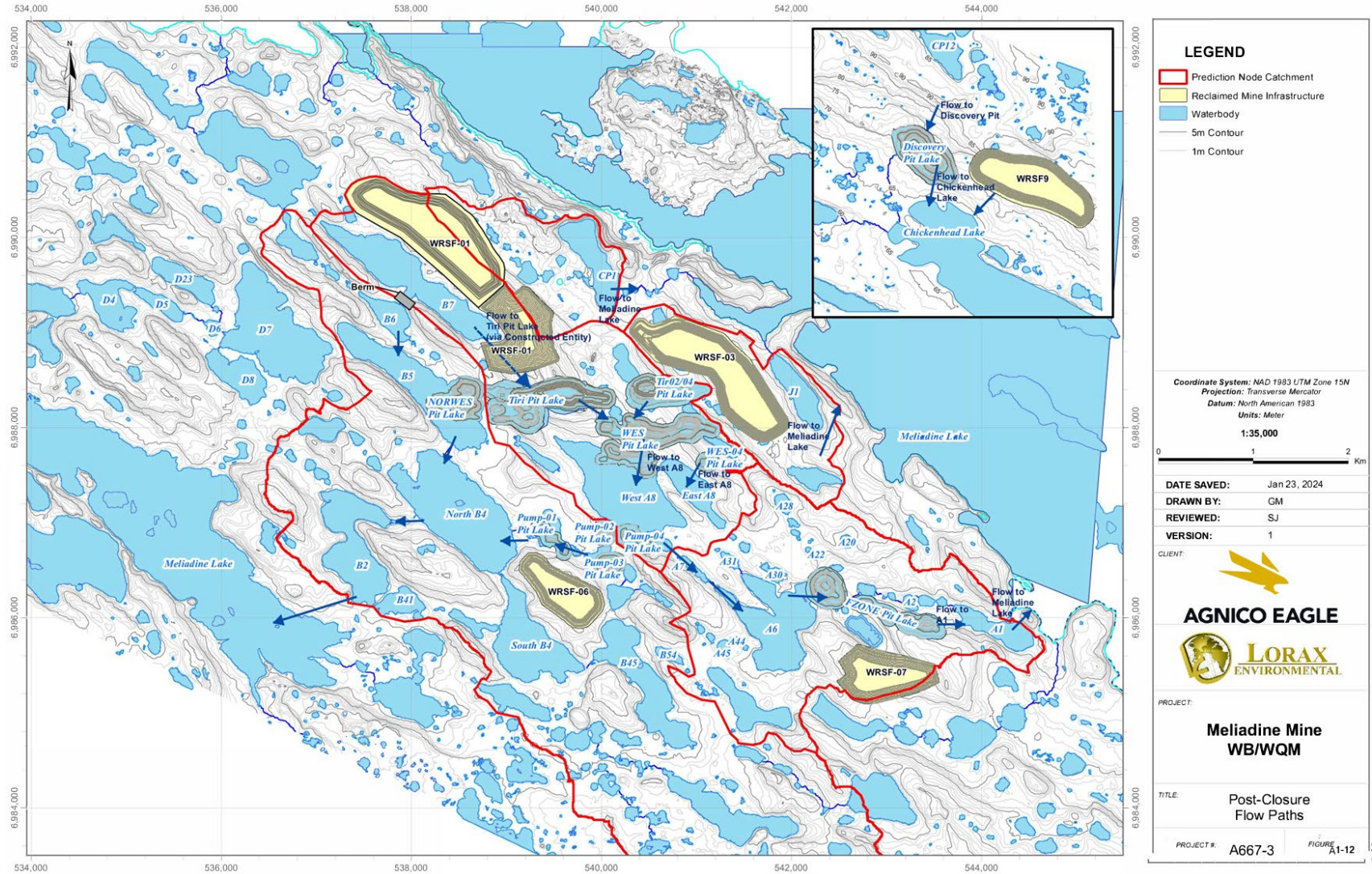

Figure 10: Mine Site Layout After Closure



**LEGEND**

- Prediction Node Catchment
- Reclaimed Mine Infrastructure
- Waterbody
- 5m Contour
- 1m Contour

Coordinate System: NAD 1983 UTM Zone 15N  
 Projection: Transverse Mercator  
 Datum: North American 1983  
 Units: Meter  
 1:35,000

0 1 2 Km

DATE SAVED: Jan 23, 2024  
 DRAWN BY: GM  
 REVIEWED: SJ  
 VERSION: 1

CLIENT:

  
**AGNICO EAGLE**

  
**LORAX ENVIRONMENTAL**

PROJECT:

**Meliadine Mine  
 WB/WQM**

TITLE: Post-Closure Flow Paths

PROJECT #: A667-3      FIGURE: A1-12

**APPENDIX A – WATERLINE OPERATION AND MAINTENANCE**

## Waterline operation and maintenance

This section describes the operation and maintenance of the Waterline system prior to, during, and following each discharge season. These measures are intended to verify system integrity and support effective spill prevention and response.

### 1. Before discharge

The leak detection system (fiber optic cable) will be calibrated during commissioning and thereafter as required during operations to ensure that potential leaks or spills can be reliably distinguished from non-leak events such as ATV or vehicle traffic or caribou crossings.

Prior to the start of each discharge season, a comprehensive visual inspection of the entire Waterline will be conducted to identify and rectify deficiencies. As approximately 80-90% of the Waterline is covered with granular material, it is protected from external influences and physical damage. The Waterline has been designed to withstand corrosion and freeze-thaw cycles typical of northern environments.

For covered sections, inspections will focus on identifying areas of significant settlement or degradation of cover material. Major deficiencies identified will be repaired prior to the commencement of discharge operations. For uncovered sections, both the Waterline and the associated fiber optic cable will be visually inspected, and repairs will be completed as required in accordance with best practices.

An annual inspection of the subsea marine pipe and diffuser will also be completed. This inspection will be carried out by specialized personnel, and required repairs will be completed<sup>1</sup>.

#### 1.1 Waterline testing

To verify the integrity of the Waterline prior to each discharge season, the system will be tested using freshwater or treated surface contact water (i.e., effluent from the Effluent Water Treatment Plant within the Water Treatment Complex (EWTP-WTC)).

During testing, treated EWTP-WTC effluent will be temporarily diverted and pumped through the Waterline at flow rates comparable to normal operating conditions (Figure 1). To redirect the EWTP-WTC effluent, valves V1, V4 and V5 will be closed, and valves V2 and V3 will be opened. The check valve CV1 is in place to prevent saline contact water from entering the EWTP-WTC network. Prior to initiating testing, Agnico Eagle will ensure that all applicable effluent discharge parameters meet MDMER requirements.

---

<sup>1</sup> The subsea marine pipe and diffuser will be inspected annually during the open water season, but may not be completed prior to the start of discharge.

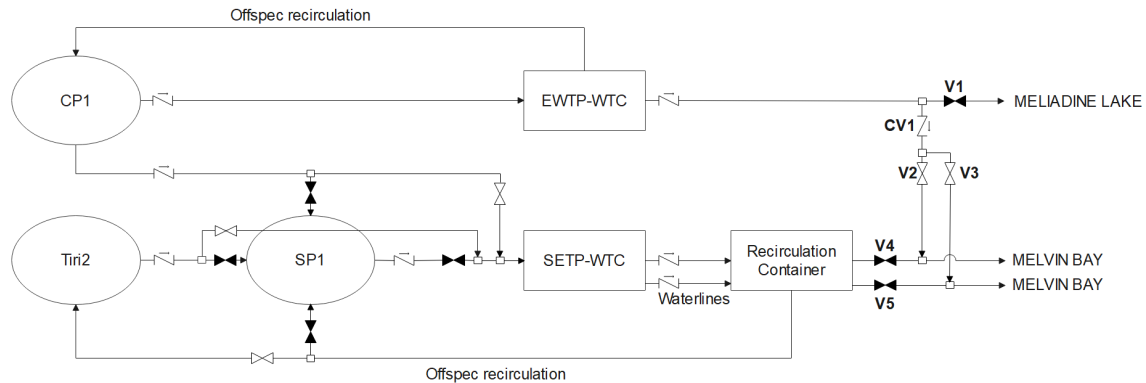

**Figure 11: Simplified Diagram of the EWTP-WTC and SETP-WTC Feed and Discharge Points**

Throughout the testing period, the Meliadine Water Management department will inspect the full length of the Waterline for signs of leakage or other abnormalities. Identified issues will be documented and fixed. If no leaks or abnormalities are observed, authorization to proceed with discharge of treated saline contact water via the Waterline will be granted by the Meliadine Water Management department.

## 2. During discharge operations

The Waterline will be operated during the open water season, typically between July and October. Regular maintenance activities and inspections will be conducted throughout the discharge period to verify ongoing system integrity and performance.

If the leak detection system is triggered, the Waterline will be promptly inspected to confirm whether a leak has occurred. Discharge operations will cease until the leak has been controlled and/or repaired. Spill response procedures associated with the Waterline operations will be followed as described in the Spill Contingency Plan.

The decision framework to assist in management of operations during the caribou migration is described in the Terrestrial Environment Management and Monitoring Plan (TEMMP), and Appendix H of the Spill Contingency Plan details spill prevention principles related to the Waterline and the protection of caribou:

- In the event that caribou with calves are spotted on site adjacent to the Waterline, Agnico Eagle will confer with KivIA, GN, KHTO and community elders and assess installing additional deterrents on site.
- To be protective of caribou, any notification from the leak detection system when caribou are in the vicinity of the AWAR would result in an immediate shutdown of that Waterline until it can be confirmed whether a leak has occurred.
- Response measures for a spill to prevent caribou from accessing or be exposed to water spilled, or released from the Waterline include containment, removal/recovery, containment berms, and long-term soil treatment.

- Additional measures to prevent caribou from accessing the area would depend on the time of year and extent of spill but regardless of the degree, the area would be isolated until it is safe for caribou to return.

### **3. After discharge**

Following completion of the discharge season, the Waterline will be winterized and deficiencies corrected to allow safe overwintering and future operation of the Waterline. The subsea pipe and diffuser will be flushed to remove low salinity effluent and prevent freezing within the infrastructure.