



## **ATTACHMENT 21**

### **LTWP Detailed Design Report - Appendix F - Pump Curves**

# Appendix F

## Pump Curves

## NP 3315 LT 3~ 627

Patented self cleaning semi-open channel impeller, ideal for pumping in waste water applications. Modular based design with high adaptation grade.



### Technical specification



Curves according to: Water, pure Water, pure [100%], 4 °C, 1 kg/dm<sup>3</sup>, 1.569 mm<sup>2</sup>/s

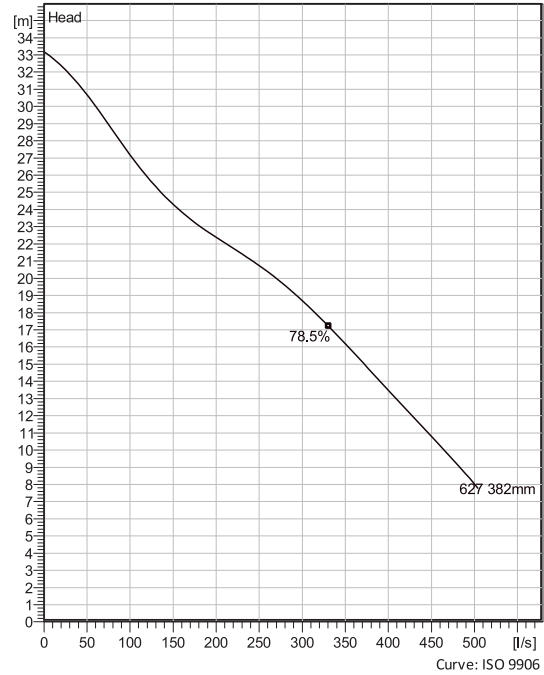

Nominal (mean) data shown. Under- and over-performance from this data should be expected due to standard manufacturing tolerances. Please consult your local Flygt representative for performance guarantees.

### Configuration

<b>Motor number</b> N3315.185 35-35-6AA-W <b>110hp</b>	<b>Installation type</b> P - Semi permanent, Wet
<b>Impeller diameter</b> 382 mm	<b>Discharge diameter</b> 300 mm

### Pump information

<b>Impeller diameter</b> 382 mm
<b>Discharge diameter</b> 300 mm
<b>Inlet diameter</b> 350 mm
<b>Maximum operating speed</b> 1185 rpm
<b>Number of blades</b> 3
<b>Max. fluid temperature</b> 40 °C

### Material

<b>Impeller</b> <b>Hard-Iron™</b>
--------------------------------------

**Project** East Marsh PS ( CG)  
**Block**

**Created by**  
**Created on** 3/1/2024 **Last update** 3/1/2024

# NP 3315 LT 3~ 627

## Technical specification



### Motor - General

<b>Motor number</b> N3315.185 35-35-6AA-W 110hp	<b>Phases</b> 3~	<b>Rated speed</b> 1185 rpm	<b>Rated power</b> 110 hp
<b>ATEX approved</b> No	<b>Number of poles</b> 6	<b>Rated current</b> 112 A	<b>Stator variant</b> 4
<b>Frequency</b> 60 Hz	<b>Rated voltage</b> 600 V	<b>Insulation class</b> H	<b>Type of Duty</b> S1
<b>Version code</b> 185			

### Motor - Technical

<b>Power factor - 1/1 Load</b> 0.76	<b>Motor efficiency - 1/1 Load</b> 92.4 %	<b>Total moment of inertia</b> 1.75 kg m <sup>2</sup>	<b>Starts per hour max.</b> 15
<b>Power factor - 3/4 Load</b> 0.70	<b>Motor efficiency - 3/4 Load</b> 92.7 %	<b>Starting current, direct starting</b> 830 A	
<b>Power factor - 1/2 Load</b> 0.57	<b>Motor efficiency - 1/2 Load</b> 91.9 %	<b>Starting current, star-delta</b> 277 A	

**Project** East Marsh PS ( CG)  
**Block**

**Created by**  
**Created on** 3/1/2024 **Last update** 3/1/2024

# NP 3315 LT 3~ 627

## Performance curve



### Duty point

**Flow**  
297 l/s

**Head**  
18.8 m

Curves according to: Water, pure Water, pure [100%], 4 °C, 1 kg/dm<sup>3</sup>, 1.569 mm<sup>2</sup>/s

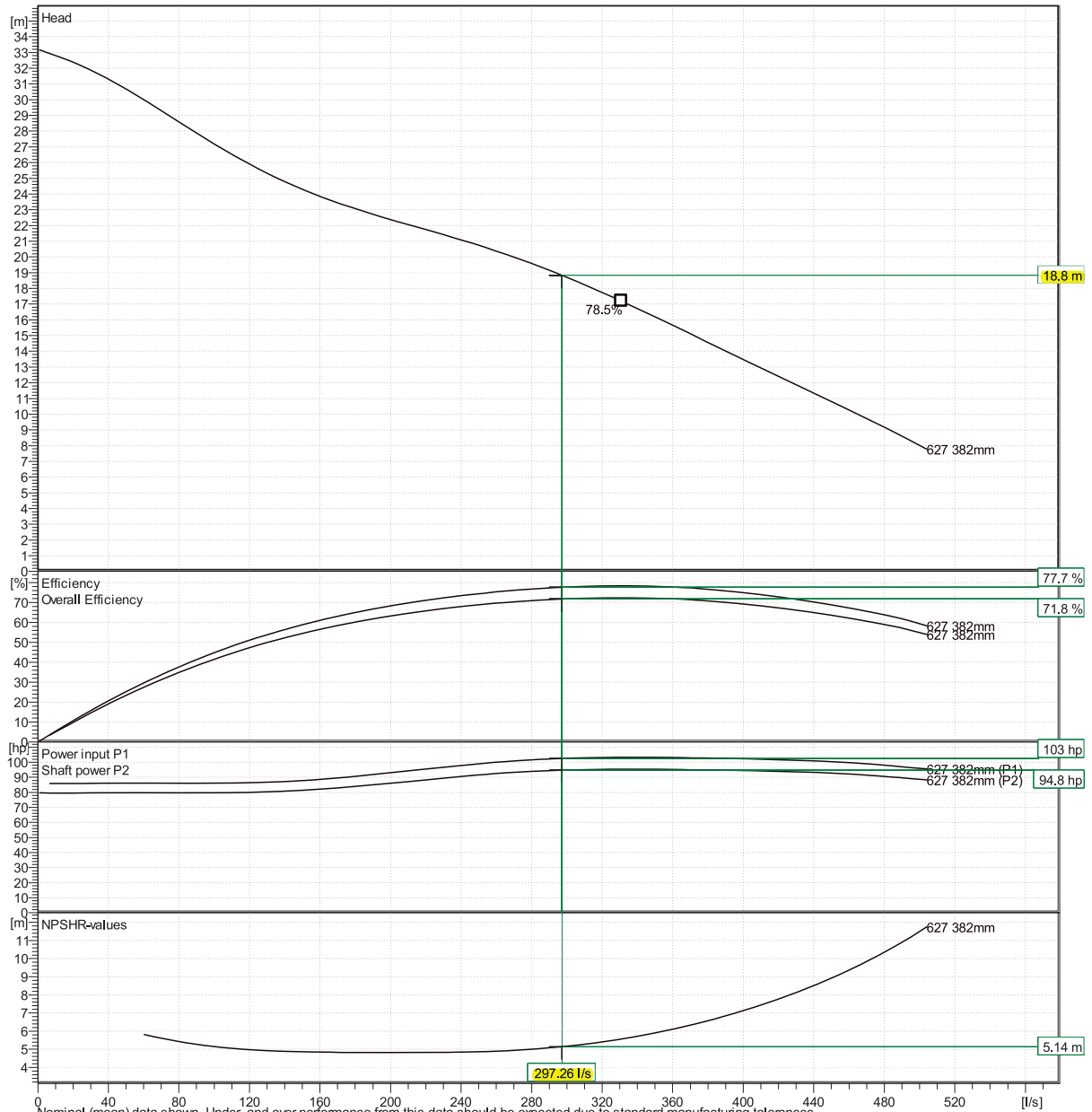

Nominal (mean) data shown. Under- and over-performance from this data should be expected due to standard manufacturing tolerances. Please consult your local Flygt representative for performance guarantees. Curve: ISO 9906

East Marsh PS ( CG )

Created on 3/1/2024 Last update 3/1/2024

# NP 3315 LT 3~ 627

## Duty Analysis



Curves according to: Water, pure [100%]; 4°C; 1kg/dm<sup>3</sup>; 1.569mm<sup>2</sup>/s

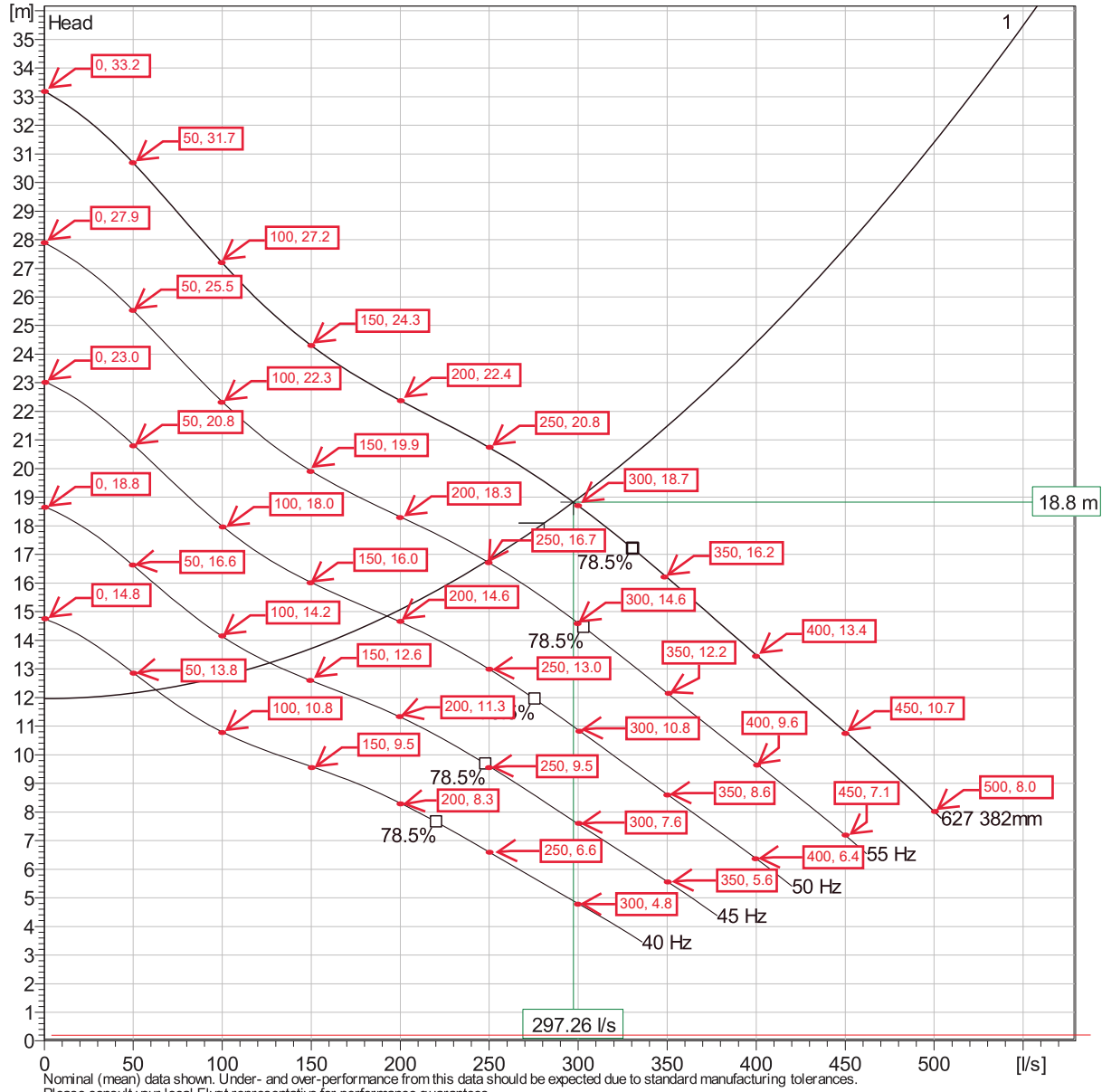

### Operating characteristics

Pumps / Systems	Flow l/s	Head m	Shaft power hp	Flow l/s	Head m	Shaft power hp	Hydr.eff.	Spec. Energy kWh/l	NPSHr m
1	297	18.8	94.8	297	18.8	94.8	77.7 %	7.15E-5	5.14

<b>Project</b>		<b>Created by</b>	
<b>Block</b>	East Marsh PS ( CG )	<b>Created on</b>	3/1/2024
		<b>Last update</b>	3/1/2024

# NP 3315 LT 3~ 627

## VFD Curve



Curves according to: Water, pure, 4 °C, 1 kg/dm<sup>3</sup>, 1.569 mm<sup>2</sup>/s

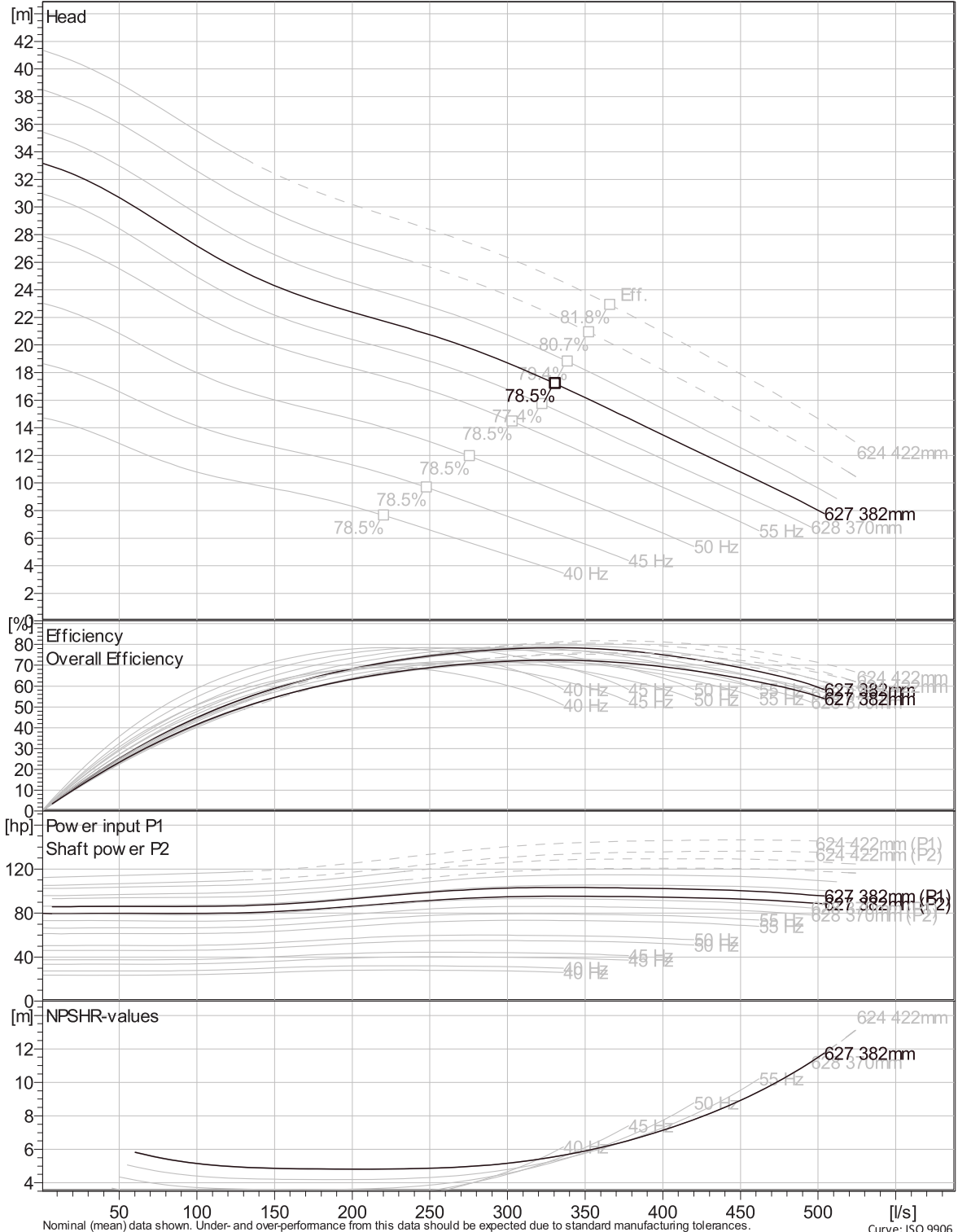

Nominal (mean) data shown. Under- and over-performance from this data should be expected due to standard manufacturing tolerances. Please consult your local Flygt representative for performance guarantees.

Curve: ISO 9906

Project	East Marsh PS ( CG )	Created by	
Block		Created on	3/1/2024
		Last update	3/1/2024

# NP 3315 LT 3~ 627

## VFD Analysis

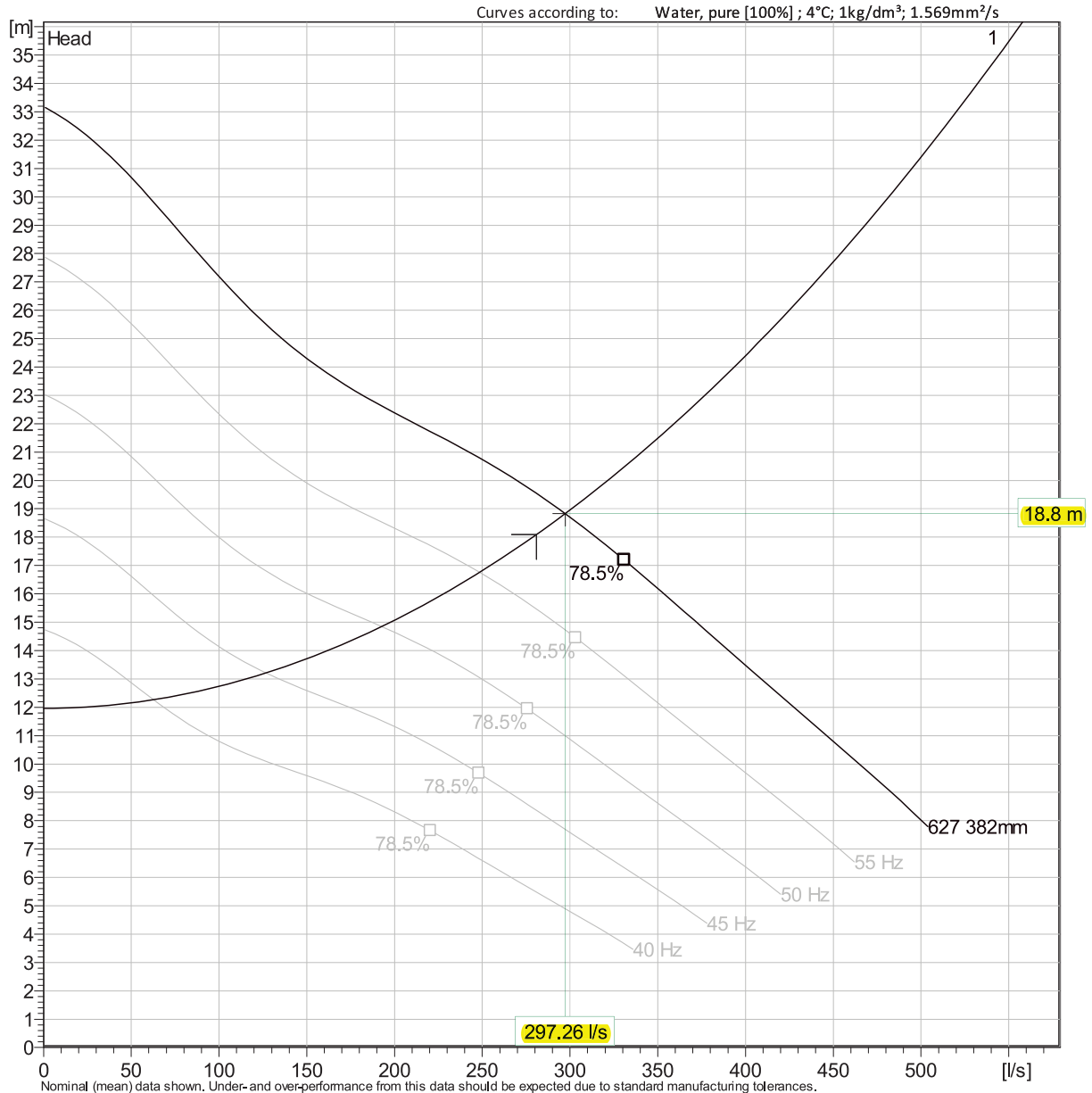

Nominal (mean) data shown. Under- and over-performance from this data should be expected due to standard manufacturing tolerances. Please consult your local Flygt representative for performance guarantees.

### Operating Characteristics

Pumps / Systems	Frequency	Flow l/s	Head m	Shaft power hp	Flow l/s	Head m	Shaft power hp	Hydr.eff.	Specific energy kWh/l	NPSHre m
1	60 Hz	297	18.8	94.8	297	18.8	94.8	77.7 %	7.15E-5	5.14
1	55 Hz	248	16.8	71.9	248	16.8	71.9	76.2 %	6.48E-5	4.31
1	50 Hz	193	14.8	51.9	193	14.8	51.9	72.5 %	6.08E-5	3.61
1	45 Hz	127	13.2	35	127	13.2	35	63 %	6.38E-5	3.05

<b>Project</b>	East Marsh PS ( CG )	<b>Created by</b>	
<b>Block</b>		<b>Created on</b>	3/1/2024
		<b>Last update</b>	3/1/2024

# NP 3315 LT 3~ 627

## VFD Analysis

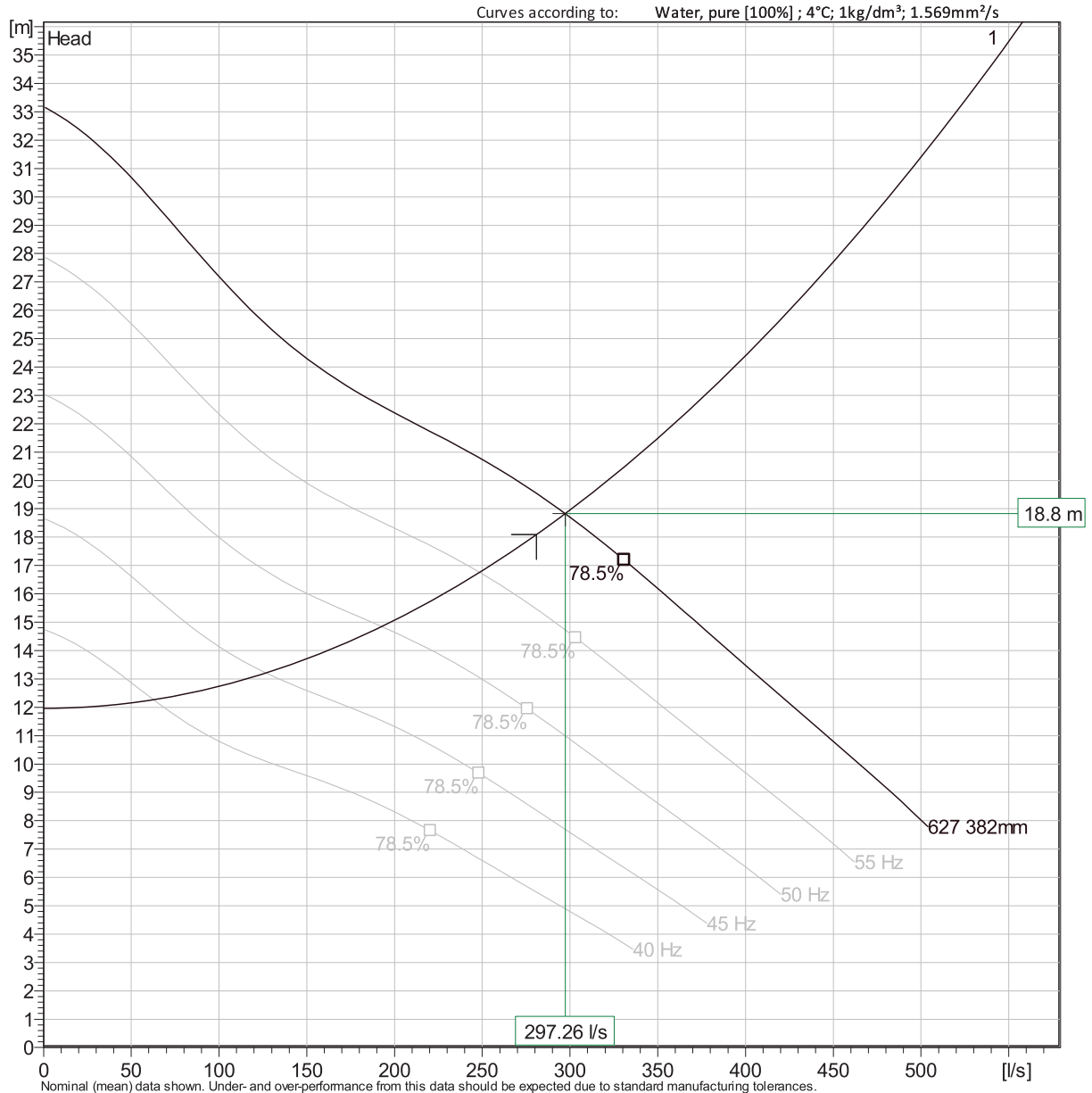

Nominal (mean) data shown. Under- and over-performance from this data should be expected due to standard manufacturing tolerances. Please consult your local Flygt representative for performance guarantees.

### Operating Characteristics

Pumps / Systems	Frequency	Flow	Head	Shaft power	Flow	Head	Shaft power	Hydr. eff.	Specific energy	NPSHre
		l/s	m	hp	l/s	m	hp		kWh/l	m
1	40 Hz	62.7	12.3	23.6	62.7	12.3	23.6	42.8 %	9.06E-5	2.73

<b>Project</b>	East Marsh PS ( CG )	<b>Created by</b>	
<b>Block</b>		<b>Created on</b>	3/1/2024
		<b>Last update</b>	3/1/2024

# NP 3315 LT 3~ 627

Dimensional drawing

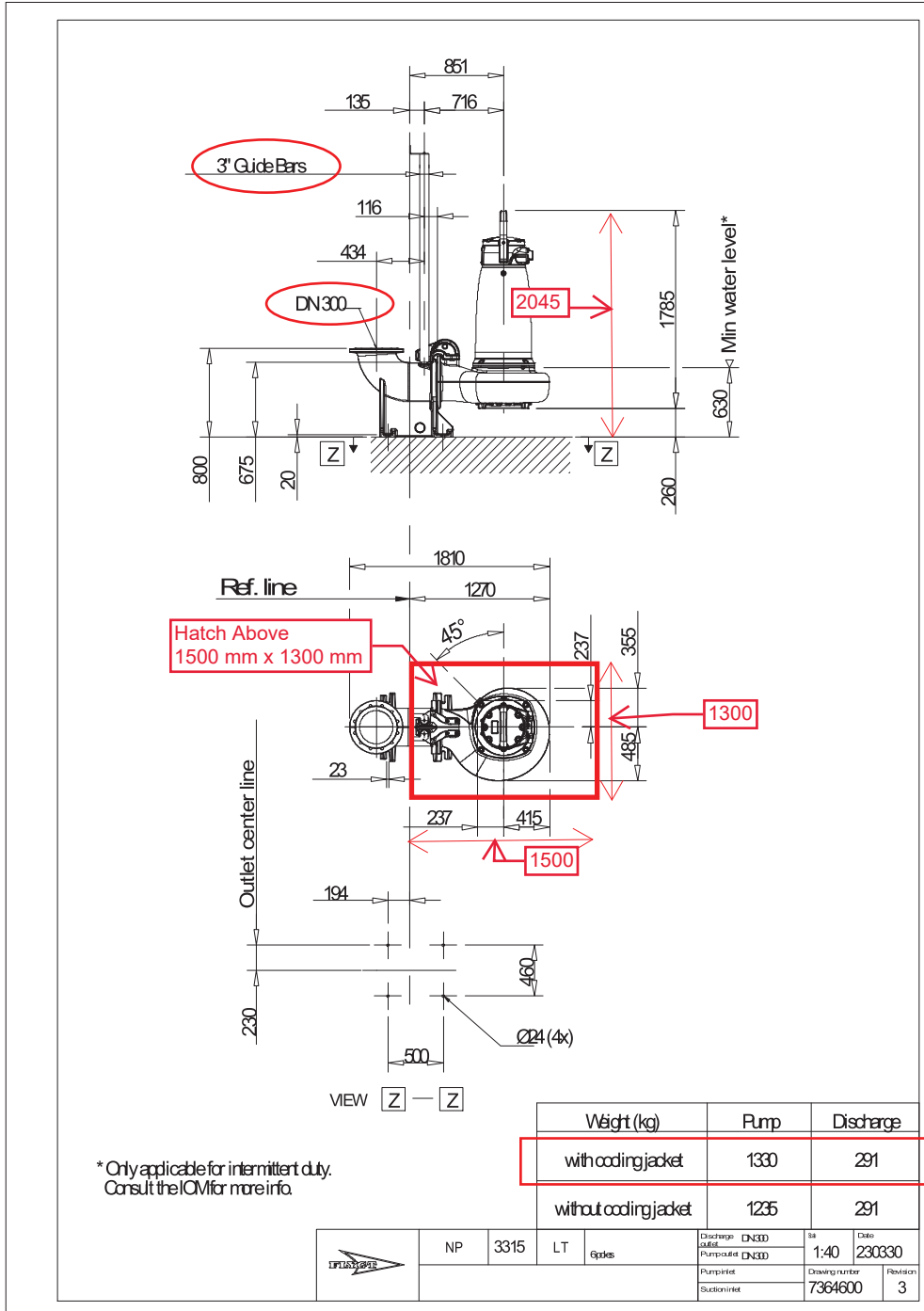

Project	East Marsh PS ( CG )	Created by	
Block		Created on	3/1/2024
		Last update	3/1/2024

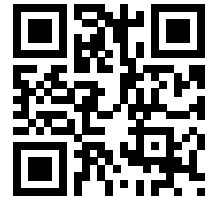
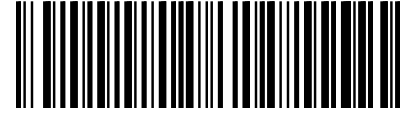

# Flygt 3315



# Table of Contents

1	Introduction and Safety.....	3
1.1	Introduction.....	3
1.2	Safety terminology and symbols.....	3
1.3	User safety.....	4
1.4	Ex-approved products.....	4
1.5	Special hazards.....	5
1.5.1	Biological hazards.....	5
1.5.2	Wash the skin and eyes.....	6
1.6	Protecting the environment.....	6
1.7	End-of-life product disposal.....	6
1.8	Spare parts.....	6
1.9	Warranty.....	6
2	Transportation and Storage.....	7
2.1	Examine the delivery.....	7
2.1.1	Examine the package.....	7
2.1.2	Examine the unit.....	7
2.2	Transportation guidelines.....	7
2.2.1	Precautions.....	7
2.2.2	Lifting.....	7
2.3	Temperature ranges for transportation, handling and storage.....	8
2.4	Storage guidelines.....	8
3	Product Description.....	10
3.1	Products included.....	10
3.2	Pump design.....	10
3.3	Monitoring equipment.....	12
3.4	The data plate.....	13
3.5	The warm liquid data plate.....	13
3.6	Motor regulation.....	14
3.7	Approvals.....	14
3.8	Product denomination.....	16
4	Installation.....	18
4.1	Precautions.....	18
4.1.1	Hazardous atmospheres.....	18
4.2	Install with P-installation.....	19
4.3	Install with S-installation.....	20
4.4	Install with Z-installation.....	21
4.5	Install with T-installation.....	22
4.6	Install with the stand.....	23
4.6.1	Find the height setting from the inlet (X).....	24
4.6.2	Find the height setting from the outlet (Y).....	24
4.6.3	Read the height setting from the table.....	24
4.6.4	Assemble the stand.....	25
4.6.5	Install the anchor bolts.....	27
4.6.6	Attach the pump housing to the stand.....	27
4.6.7	Install the stand on the anchor bolts.....	28
4.6.8	Install the drive unit on the pump housing.....	30
4.6.9	Fasteners.....	31
4.6.10	Stand dimensional drawings.....	31

4.7	Make the electrical connections.....	32
4.7.1	General precautions.....	32
4.7.2	Grounding (earthing) .....	33
4.7.3	Prepare the SUBCAB™ cables.....	34
4.7.4	Connect the motor cable to the pump.....	35
4.7.5	Connect the cables to the starter and monitoring equipment.....	38
4.8	Cable charts.....	39
4.8.1	Connection locations.....	39
4.9	MiniCAS.....	44
4.10	MAS 801.....	46
4.11	MAS 711.....	50
4.12	T-installation: Bleed air before starting pump.....	50
4.13	Check the impeller rotation.....	51
5	Operation.....	52
5.1	Precautions.....	52
5.2	Estimate zinc anode replacement intervals.....	52
5.3	Start the pump.....	53
6	Maintenance.....	54
6.1	Precautions.....	54
6.2	Maintenance guidelines.....	54
6.3	Torque values.....	55
6.4	Change the coolant.....	55
6.4.1	Empty the coolant.....	56
6.4.2	Fill with coolant.....	58
6.5	Service the pump.....	59
6.5.1	Inspection.....	59
6.5.2	Overhaul.....	61
6.5.3	Service in case of alarm.....	61
6.6	Replace the impeller.....	61
6.6.1	Replace the impeller for wet installation.....	62
6.6.2	Replace the impeller for dry installation.....	67
6.6.3	Handle the screw unit.....	76
6.7	Pumps with MAS 801: Replace the PEM.....	78
7	Troubleshooting.....	79
7.1	Electrical troubleshooting.....	79
7.2	The pump does not start.....	79
7.3	The pump does not stop when a level sensor is used.....	80
7.4	The pump starts-stops-starts in rapid sequence.....	80
7.5	The pump runs but the motor protection trips.....	81
7.6	The pump delivers too little or no water.....	82
8	Technical Reference.....	83
8.1	Application limits.....	83
8.2	Motor data.....	83
8.3	Sensor characteristics.....	83
8.4	Wiring diagram: MiniCAS II.....	84

# 1 Introduction and Safety

## 1.1 Introduction

EN

### Purpose of the manual

The purpose of this manual is to provide the necessary information for working with the unit. Read this manual carefully before starting work.

### Read and keep the manual

Save this manual for future reference, and keep it readily available at the location of the unit.

### Intended use



#### WARNING:

Operating, installing, or maintaining the unit in any way that is not covered in this manual could cause death, serious personal injury, or damage to the equipment and the surroundings. This includes any modification to the equipment or use of parts not provided by Xylem. If there is a question regarding the intended use of the equipment, please contact a Xylem representative before proceeding.

### Other manuals

See also the safety requirements and information in the original manufacturer's manuals for any other equipment furnished separately for use in this system.



## 1.2 Safety terminology and symbols

### About safety messages

It is extremely important that you read, understand, and follow the safety messages and regulations carefully before handling the product. They are published to help prevent these hazards:



- Personal accidents and health problems
- Damage to the product and its surroundings
- Product malfunction

### Hazard levels

Hazard level	Indication
 <b>DANGER:</b>	A hazardous situation which, if not avoided, will result in death or serious injury
 <b>WARNING:</b>	A hazardous situation which, if not avoided, could result in death or serious injury
 <b>CAUTION:</b>	A hazardous situation which, if not avoided, could result in minor or moderate injury
<b>NOTICE:</b>	Notices are used when there is a risk of equipment damage or decreased performance, but not personal injury.

## Special symbols

Some hazard categories have specific symbols, as shown in the following table.

Electrical hazard	Magnetic fields hazard
 <p data-bbox="583 275 768 302">Electrical Hazard:</p>	 <p data-bbox="1127 275 1240 302">CAUTION:</p>

## 1.3 User safety

All regulations, codes, and health and safety directives must be observed.

### The site

- Observe lockout and tagout procedures before starting work on the product, such as transportation, installation, maintenance, or service.
- Pay attention to the risks presented by gas and vapors in the work area.
- Always be aware of the area surrounding the equipment, and any hazards posed by the site or nearby equipment.

### Qualified personnel

This product must be installed, operated, and maintained by qualified personnel only.

### Protective equipment and safety devices

- Use personal protective equipment as needed. Examples of personal protective equipment include, but are not limited to, hard hats, safety goggles, protective gloves and shoes, and breathing equipment.
- Make sure that all safety features on the product are functioning and in use at all times when the unit is being operated.

## 1.4 Ex-approved products

Follow these special handling instructions if you have an Ex-approved unit.

### Personnel requirements

These are the personnel requirements for Ex-approved products in potentially explosive atmospheres:

- All work on the product must be carried out by certified electricians and Xylem authorized mechanics. Special rules apply to installations in explosive atmospheres.
- All users must know about the risks of electric current and the chemical and physical characteristics of the gas, the vapor, or both present in hazardous areas.
- Any maintenance for Ex-approved products must conform to international and national standards (for example, IEC/EN 60079-17).

Xylem disclaims all responsibility for work done by untrained and unauthorized personnel.

### Product and product handling requirements

These are the product and product handling requirements for Ex-approved products in potentially explosive atmospheres:

- Only use the product in accordance with the approved motor data.
- The equipment must never run dry during operation. The volute must be filled with liquid during operation. Dry running during service and inspection is only permitted outside the classified area.
- Before you start work on the product, make sure that the product and the control panel are isolated from the power supply and the control circuit, so they cannot be energized.
- Do not open the product while it is energized or in an explosive gas atmosphere.

- Intrinsically safe circuits are normally required for the automatic level-control system by the level regulator if mounted in zone 0.
- The yield stress of fasteners must be in accordance with the approval drawing and the product specification.
- Do not modify the equipment without approval from an Ex-approved Xylem representative.
- Only use original Xylem spare parts that are provided by an Ex-approved Xylem representative.
- The thermal contacts that are fitted to the stator windings must be connected correctly to a separate motor control circuit and in use. The thermal contacts shall be connected to a monitoring device, which disconnects the power supply immediately upon activation. This action prevents the rise of temperatures above the temperature value for the approval classification.
- The width of flameproof joints is more than the values specified in the tables of the EN/IEC 60079-1 standard. For information contact the manufacturer.
- The gap of flameproof joints is less than the values specified in Table 2 of the EN/IEC 60079-1 standard. For information contact the manufacturer.
- It is NOT allowed to repair the flameproof joints.
- Ambient temperature:  $-20^{\circ}\text{C}$  to  $60^{\circ}\text{C}$

### Guidelines for compliance

Compliance is fulfilled only when you operate the unit within its intended use. Do not change the conditions of the service without the approval of an Ex-approved Xylem representative. When you install or maintain explosion proof products, always comply with the directive and applicable standards (for example, IEC/EN 60079–14).

### Minimum permitted liquid level

See the dimensional drawings of the product for the minimum permitted liquid level according to the approval for explosion proof products. If the information is missing on the dimensional drawing, the product must be fully submerged. Level-sensing equipment must be installed if the product can be operated at less than the minimum submersion depth.

### Monitoring equipment

For additional safety, use condition-monitoring devices. Examples of condition-monitoring devices include, but are not limited to, the following:

- Level indicators
- Temperature detectors in addition to the stator thermal detectors

Any thermal detectors or thermal protection devices delivered with the pump must be installed and in use at all times.

The site owner is responsible for selection, installation, and proper maintenance of functional monitoring equipment for motor protection.

## 1.5 Special hazards

### 1.5.1 Biological hazards

The product is designed for use in liquids that can be hazardous to your health. Observe these rules when you work with the product:

- Make sure that all personnel who may come into contact with biological hazards are vaccinated against diseases to which they may be exposed.
- Observe strict personal cleanliness.



---

#### **WARNING: Biological Hazard**

Infection risk. Rinse the unit thoroughly with clean water before working on it.

---

## 1.5.2 Wash the skin and eyes

Follow these procedures for chemicals or hazardous fluids that have come into contact with your eyes or your skin:

Condition	Action
Chemicals or hazardous fluids in eyes	<ol style="list-style-type: none"> <li>1. Hold your eyelids apart forcibly with your fingers.</li> <li>2. Rinse the eyes with eyewash or running water for at least 15 minutes.</li> <li>3. Seek medical attention.</li> </ol>
Chemicals or hazardous fluids on skin	<ol style="list-style-type: none"> <li>1. Remove contaminated clothing.</li> <li>2. Wash the skin with soap and water for at least 1 minute.</li> <li>3. Seek medical attention, if necessary.</li> </ol>

## 1.6 Protecting the environment

### Emissions and waste disposal

Observe the local regulations and codes regarding:

- Reporting of emissions to the appropriate authorities
- Sorting, recycling and disposal of solid or liquid waste
- Clean-up of spills

### Exceptional sites



#### CAUTION: Radiation Hazard

Do NOT send the product to Xylem if it has been exposed to nuclear radiation, unless Xylem has been informed and appropriate actions have been agreed upon.

## 1.7 End-of-life product disposal

Handle and dispose of all waste in compliance with local laws and regulations.

### EU and UK only: Correct disposal of this product — waste electrical and electronic equipment

- EU: Directive 2012/19/EU on waste electrical and electronic equipment (WEEE)
- UK: SI 2013 No. 3113



WSD00973B

This marking on the product, accessories or literature indicates that the product should not be disposed of with other waste at the end of its working life.

## 1.8 Spare parts



#### CAUTION:

Only use the manufacturer's original spare parts to replace any worn or faulty components. The use of unsuitable spare parts may cause malfunctions, damage, and injuries as well as void the warranty.

## 1.9 Warranty

For information about warranty, see the sales contract.

# 2 Transportation and Storage

## 2.1 Examine the delivery

EN

### 2.1.1 Examine the package

1. Examine the package for damaged or missing items upon delivery.
2. Record any damaged or missing items on the receipt and freight bill.
3. If anything is out of order, then file a claim with the shipping company.  
If the product has been picked up at a distributor, make a claim directly to the distributor.

### 2.1.2 Examine the unit

1. Remove packing materials from the product.  
Dispose of all packing materials in accordance with local regulations.
2. To determine whether any parts have been damaged or are missing, examine the product.
3. If applicable, unfasten the product by removing any screws, bolts, or straps.  
Use care around nails and straps.
4. If there is any issue, then contact a sales representative.

## 2.2 Transportation guidelines

### 2.2.1 Precautions



---

#### **DANGER: Crush Hazard**

Moving parts can entangle or crush. Always disconnect and lock out power before servicing to prevent unexpected startup. Failure to do so could result in death or serious injury.



#### **Position and fastening**

The unit can be transported either horizontally or vertically. Make sure that the unit is correctly fastened during transportation, and cannot roll or fall over.

### 2.2.2 Lifting

Always inspect the lifting equipment and tackle before starting any work.



---

#### **WARNING: Crush Hazard**

Always lift the unit by its designated lifting points.  
Use suitable lifting equipment and ensure that the product is properly harnessed.  
Wear personal protective equipment.  
Stay clear of cables and suspended loads.

---

#### **NOTICE:**

Never lift the unit by its cables or hose.

---

#### **Lifting equipment**

Lifting equipment is always required to handle the unit. The lifting equipment must fulfill the following requirements:

- The minimum height between the lifting hook and the floor must be sufficient to lift the unit. Contact a Xylem representative for more information.
- The lifting equipment must be able to hoist the unit straight up and down, preferably without the need for resetting the lifting hook.
- The lifting equipment must be correctly anchored and in good condition.
- The lifting equipment must support the weight of the entire assembly. Only authorized personnel may use the lifting equipment.
- Two sets of lifting equipment must be used to lift the unit for repair work.
- The lifting equipment must be dimensioned to lift the unit with any remaining pumped media in it.
- The lifting equipment must not be oversized.

**CAUTION: Crush Hazard**

Improperly-dimensioned lifting equipment can lead to injury. A site-specific risk analysis must be done.

## 2.3 Temperature ranges for transportation, handling and storage

### Handling at freezing temperature

At temperatures below freezing, the product and all installation equipment, including the lifting gear, must be handled with extreme care.

Make sure that the product is warmed up to a temperature above the freezing point before starting up. Avoid rotating the impeller/propeller by hand at temperatures below the freezing point. The recommended method to warm the unit up is to submerge it in the liquid which will be pumped or mixed.

**NOTICE:**

Never use a naked flame to thaw the unit.

### Unit in as-delivered condition

If the unit is still in the condition in which it left the factory - all packing materials are undisturbed - then the acceptable temperature range during transportation, handling and storage is:  $-50^{\circ}\text{C}$  ( $-58^{\circ}\text{F}$ ) to  $+60^{\circ}\text{C}$  ( $+140^{\circ}\text{F}$ ).

If the unit has been exposed to freezing temperatures, then allow it to reach the ambient temperature of the sump before operating.

### Lifting the unit out of liquid

The unit is normally protected from freezing while operating or immersed in liquid, but the impeller/propeller and the shaft seal may freeze if the unit is lifted out of the liquid into a surrounding temperature below freezing.

Follow these guidelines to avoid freezing damage:

1. Empty all pumped liquid, if applicable.
2. Check all liquids used for lubrication or cooling, both oil and water-glycol mixtures, for the presence of unacceptable amounts of water. Change if needed.

Water-glycol mixtures: Units equipped with an internal closed-loop cooling system are filled with a mixture of water and 30% glycol. This mixture remains a flowing liquid at temperatures down to  $-13^{\circ}\text{C}$  ( $9^{\circ}\text{F}$ ). Below  $-13^{\circ}\text{C}$  ( $9^{\circ}\text{F}$ ), the viscosity increases such that the glycol mixture will lose its flow properties. However, the glycol-water mixture will not solidify completely and thus cannot harm the product.

## 2.4 Storage guidelines

### Storage location

The product must be stored in a covered and dry location free from heat, dirt, and vibrations.

---

**NOTICE:**

Protect the product against humidity, heat sources, and mechanical damage.

---

**NOTICE:**

Do not place heavy weights on the packed product.

---

EN

**Long-term storage**

If the unit is stored for more than six months, then the following apply:

- Before operating the unit after storage, it must be inspected. Special attention must be given to the seals and the cable entry.
- The impeller or propeller must be rotated every other month to prevent the seals from sticking together.

# 3 Product Description

## 3.1 Products included

Pump model	Standard version Non-explosion proof	Explosion proof version	N-hydraulic	Impeller material		
				Gray iron	Hard-Iron	Stainless steel
3315.090		X	X	X		
3315.095		X	X		X	
3315.180	X		X	X		
3315.185	X		X		X	
3315.660	X		X			X
3315.670		X	X			X

### Pump-specific information

For the specific weight, current, voltage, power ratings, and speed of the pump, see the data plate.

## 3.2 Pump design

The pump is submersible, and driven by an electric motor.

### Intended use

The product is intended for moving wastewater, sludge, raw and clean water. Always follow the limits that are given in [Technical Reference](#) on page 83. If there is a question regarding the intended use of the equipment, please contact a local sales and service representative before proceeding.



### DANGER: Explosion/Fire Hazard

Special rules apply to installations in explosive or flammable atmospheres. Do not install the product or any auxiliary equipment in an explosive zone unless it is rated explosion-proof or intrinsically-safe. If the product is rated explosion-proof or intrinsically-safe, then see the specific explosion-proof information in the safety chapter before taking any further actions.

### NOTICE:

Do NOT use the unit in highly corrosive liquids.

### Spare parts

- Modifications to the unit or installation should only be carried out after consulting with Xylem.
- Original spare parts and accessories that are authorized by Xylem are essential for compliance. The use of other parts can invalidate any claims for warranty or compensation. For more information contact your Xylem representative.

### Pressure class

LT	Low head
MT	Medium head

HT High head

## Parts

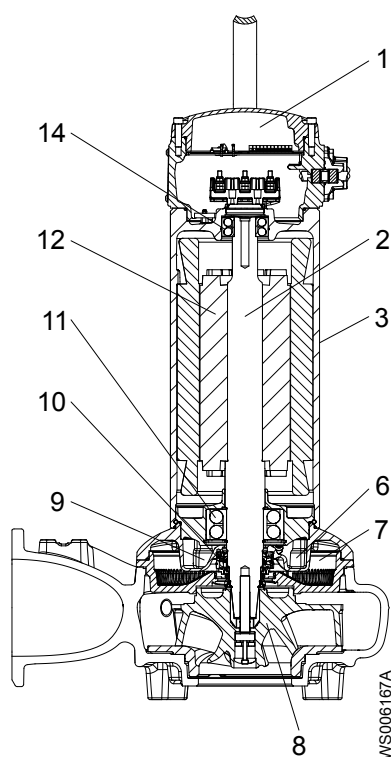

Figure 1: Without cooling jacket

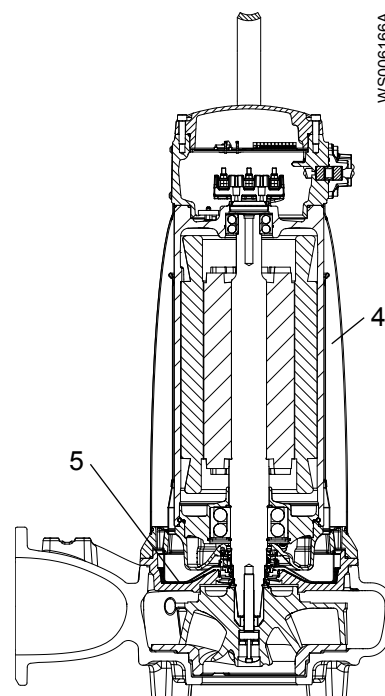

Figure 2: With cooling jacket

Position	Denomination	Description
1	Monitoring sensor	Optional sensor. For information about sensors, see <a href="#">Sensors and monitoring equipment</a> .
2	Shaft	Stainless steel, with an integrated rotor
3	Cooling without jacket	The pump is cooled by the ambient liquid.
4	Cooling with jacket	The motor is cooled by a closed loop system. An integrated coolant pump circulates the coolant whenever the pump is operated. The cooling jacket can also be used with an external cooling system. For more information, see <a href="#">External cooling</a> on page 12
5	Flow diffuser	Provides heat transfer from the coolant to the pumped fluid
6	FLS10	For information about FLS10, see <a href="#">Sensors and monitoring equipment</a> .
7	Seal housing	Includes a coolant that lubricates and cools the seals; the housing acts as a buffer between the pumped fluid and the electric motor
8	Impeller	N-impeller, a semi-open, three-vane impeller
9	Inspection chamber	Equipped with an FLS10 leakage sensor to prevent damage to the motor
10	Mechanical seals	Made of one of the following alternatives: <ul style="list-style-type: none"> <li>• Alternative 1 <ul style="list-style-type: none"> <li>– Inner seal: corrosion-resistant cemented carbide WCCR/WCCR</li> <li>– Outer seal: corrosion-resistant cemented carbide WCCR/WCCR</li> </ul> </li> <li>• Alternative 2 <ul style="list-style-type: none"> <li>– Inner seal: corrosion-resistant cemented carbide WCCR/WCCR</li> <li>– Outer seal: silicon carbide RSiC/RSiC</li> </ul> </li> </ul>

Position	Denomination	Description
11	Main bearing	Consisting of a two-row angular contact ball bearing
12	Motor	For information about the motor, see <a href="#">Technical Reference</a> on page 83.
13	Thermal contact/ Thermistors	For information about the thermal contact and thermistors, see <a href="#">Sensors and monitoring equipment</a> .
14	Support bearing	Consisting of a two-row angular contact ball bearing Option: Insulated against the passage of current

### External cooling

The following items are required in order to use external cooling:

- Cooling jacket
- Inlet/outlet pipes with M16 threads (replacing the coolant plugs)
- External cooling system (hose, water source, etc.)

Contact a sales or authorized service representative.

## 3.3 Monitoring equipment

There are standard and optional sensors that are connected to the monitoring equipment. The monitoring equipment must be designed so that it is possible to avoid an automatic restart.

It is possible to use the following monitoring systems:

- MiniCAS II
- MAS 801
- MAS 711

For more information about the monitoring systems, see the applicable documentation.

### Ex-approved pumps

Any thermal detectors or thermal personal protective equipment that is delivered with the pump must be installed and in use always.

The site owner is responsible for the selection, the installation, and the correct maintenance of functional monitoring equipment for motor protection.

### Sensors

These sensors are always included in the pump.

Thermal contacts	<ul style="list-style-type: none"> <li>• The stator has three thermal contacts that are connected in series.</li> <li>• The thermal contacts activate the alarm and stop the pump at overtemperature.</li> </ul>
FLS10, float switch	<ul style="list-style-type: none"> <li>• Detects liquid</li> <li>• Installed in the inspection chamber</li> <li>• Recommended for pumps in a vertical position</li> </ul>

### Sensors and pump memory, optional

Pt100, analog temperature sensor	Optional locations: <ul style="list-style-type: none"> <li>• Stator winding</li> <li>• Main bearing</li> <li>• Support bearing</li> </ul>
FLS, leakage sensor	Optional location: <ul style="list-style-type: none"> <li>• Junction box</li> </ul>
Current transformer, used for MAS 801	Measures the pump current and speed

- |  |   |
|--|---|
| <p>Pump electronic module (PEM), used for MAS 801</p> <p>VIS 10, vibration sensor, used for MAS 711</p> <p>Pump memory, used for MAS 711</p> | <ul style="list-style-type: none"> <li>• Interfaces with all the pump sensors and communicates the measurement values over two wires</li> <li>• Contains an integrated 3-axis vibration sensor</li> <li>• Contains pump data plate information</li> <li>• Contains configurations of the monitoring system</li> <li>• Stores measurement and service data</li> </ul> <ul style="list-style-type: none"> <li>• Measures 1-axis vibration</li> <li>• Located in the junction box</li> </ul> <ul style="list-style-type: none"> <li>• Contains configurations of the monitoring system</li> <li>• Stores the running statistics</li> </ul> |
|--|---|

### 3.4 The data plate

The data plate is a metal label that is located on the main body of the products. The data plate lists key product specifications. Specially approved products also have an approval plate.

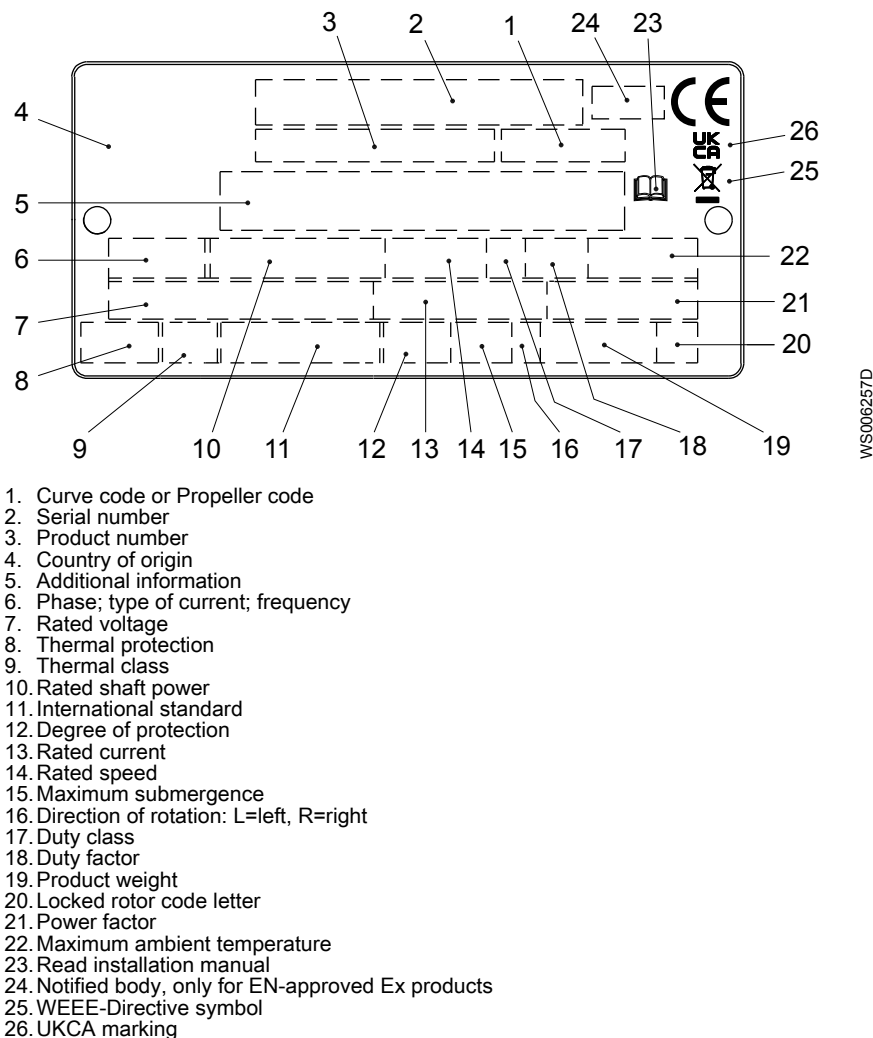

1. Curve code or Propeller code
2. Serial number
3. Product number
4. Country of origin
5. Additional information
6. Phase; type of current; frequency
7. Rated voltage
8. Thermal protection
9. Thermal class
10. Rated shaft power
11. International standard
12. Degree of protection
13. Rated current
14. Rated speed
15. Maximum submergence
16. Direction of rotation: L=left, R=right
17. Duty class
18. Duty factor
19. Product weight
20. Locked rotor code letter
21. Power factor
22. Maximum ambient temperature
23. Read installation manual
24. Notified body, only for EN-approved Ex products
25. WEEE-Directive symbol
26. UKCA marking

Figure 3: The data plate

### 3.5 The warm liquid data plate

If the product is approved for warm liquid application, an additional warm liquid data plate is attached to the product. The warm liquid data plate specifies the maximum input power and the rated current for each related maximum ambient temperature.

EN

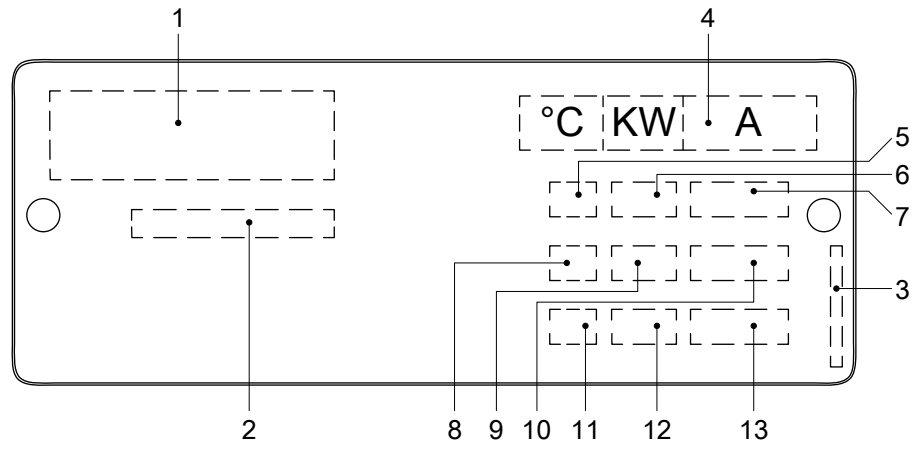

WS015533A

- 1. Brand
- 2. Text
- 3. Part number
- 4. Header
- 5. Maximum ambient temperature 1
- 6. Maximum power input 1
- 7. Rated current 1
- 8. Maximum ambient temperature 2
- 9. Maximum power input 2
- 10. Rated current 2
- 11. Maximum ambient temperature 3
- 12. Maximum power input 3
- 13. Rated current 3

Figure 4: The warm liquid data plate

### 3.6 Motor regulation

This product is submersible and therefore exempted from the motor efficiency requirement, in accordance with EU commission regulation 2019/1781 Article 2(2)(e).

### 3.7 Approvals

#### Product approvals for hazardous locations

3315

This table shows product approvals for the following products:

- 3315.090
- 3315.095
- 3315.670

Type	Approval
European Norm (EN)	<ul style="list-style-type: none"> <li>• ATEX Directive 2014/34/EU</li> <li>• EN IEC 60079-0:2018, EN 60079-1:2014, EN ISO 80079-36:2016, EN ISO 80079-37:2016</li> <li>•  II 2 G Ex db h IIB T3 Gb</li> </ul>
IEC	<ul style="list-style-type: none"> <li>• IECEx scheme 02</li> <li>• IEC 60079-0:2017, IEC 60079-1:2014-06, ISO 80079-36:2016, ISO 80079-37:2016</li> <li>• Ex db h IIB T3 Gb</li> </ul>
FM (FM Approvals)	<ul style="list-style-type: none"> <li>• Explosion proof for use in Class I, Div. 1, Group C and D</li> <li>• Dust ignition proof for use in Class II, Div. 1, Group E, F and G</li> <li>• Suitable for use in Class III, Div. 1, Hazardous Locations</li> </ul>
CSA Ex	<ul style="list-style-type: none"> <li>• Explosion proof for use in Class I, Div. 1, Group C and D</li> </ul>

Type	Approval
UKEx	<ul style="list-style-type: none"> <li>• UK SI 2016 No. 1107</li> <li>• EN IEC 60079-0:2018, EN 60079-1:2014, EN ISO 80079-36:2016, EN ISO 80079-37:2016</li> <li>•  II 2 G Ex db h IIB T3 Gb</li> </ul>

EN

### EN approval plate

This illustration describes the EN approval plate and the information that is contained in its fields.

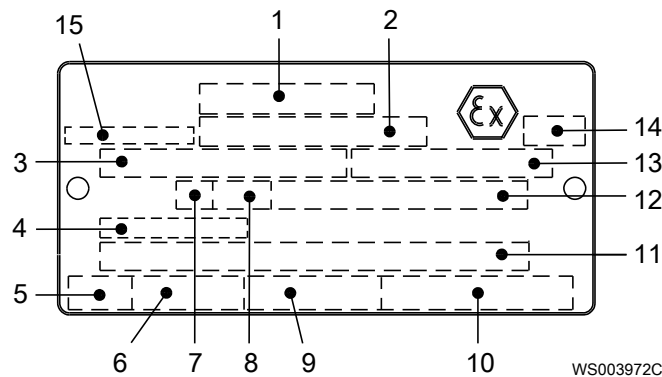

1. Approval
2. Approval authority and Approval number
3. Approved drive unit
4. Cable entry temperature
5. Stall time
6. Starting current or Rated current
7. Duty class
8. Duty factor
9. Input power
10. Rated speed
11. Additional information
12. Maximum ambient temperature
13. Serial number
14. ATEX marking
15. Country of origin

### IEC approval plate

This illustration describes the IEC approval plate and the information that is contained in its fields.

International Norm; not for EU member countries.

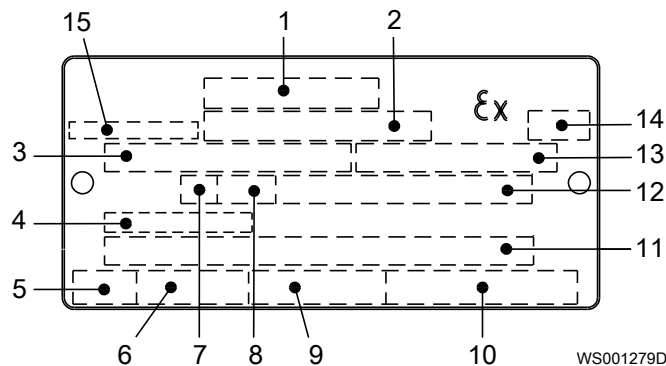

1. Approval
2. Approval authority and Approval number
3. Approved drive unit
4. Cable entry temperature
5. Stall time
6. Starting current or Rated current
7. Duty class
8. Duty factor
9. Input power
10. Rated speed
11. Additional information
12. Maximum ambient temperature
13. Serial number
14. ATEX marking
15. Country of origin

### FM approval plate

This illustration describes the FM approval plate and the information that is contained in its fields.

EN

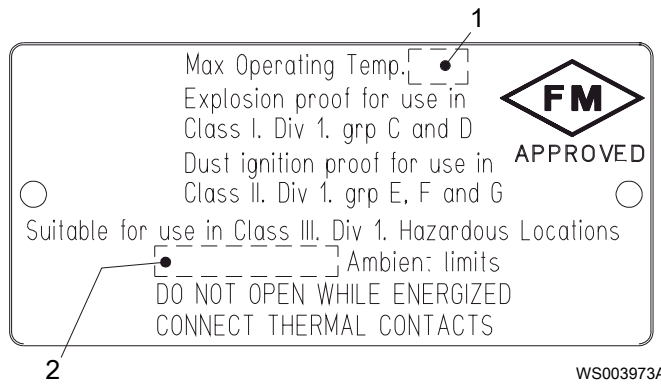

- 1. Temperature class
- 2. Maximum ambient temperature

**CSA approval plate**

This illustration describes the CSA approval plate and the information that is contained in its fields.

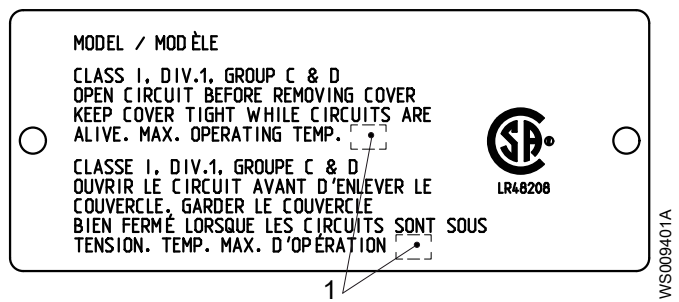

- 1. Temperature class

**United Kingdom: UKEx approval plate**

This illustration describes the UKEx approval plate and the information that is contained in its fields.

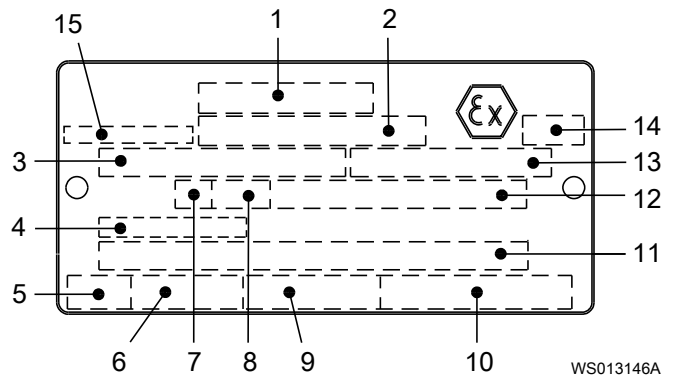

- 1. Approval
- 2. Approval authority and Approval number
- 3. Approved drive unit
- 4. Cable entry temperature
- 5. Stall time
- 6. Starting current or Rated current
- 7. Duty class
- 8. Duty factor
- 9. Input power
- 10. Rated speed
- 11. Additional information
- 12. Maximum ambient temperature
- 13. Serial number
- 14. UKEx marking
- 15. Country of origin

**3.8 Product denomination**

**Reading instruction**

In this section, code characters are illustrated accordingly:

X = letter

Y = digit

The different types of codes are marked up with a, b and c. Code parameters are marked up with numbers.

## Codes and parameters

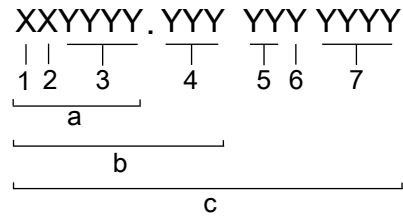

WS006265B

EN

Type of Callout	Number	Indication
Type of code	a	Sales denomination
	b	Product code
	c	Serial number
Parameter	1	Hydraulic end
	2	Type of installation
	3	Sales code
	4	Version
	5	Production year
	6	Production cycle
	7	Running number

# 4 Installation

## 4.1 Precautions



Before starting work, make sure that the safety instructions have been read and understood.

---

### **DANGER: Electrical Hazard**

Before starting work on the unit, make sure that the unit and the control panel are isolated from the power supply and cannot be energized. This applies to the control circuit as well.



---

### **DANGER: Inhalation Hazard**

Before entering the work area, make sure that the atmosphere contains sufficient oxygen and no toxic gases.

### 4.1.1 Hazardous atmospheres



---

### **DANGER: Explosion/Fire Hazard**

Special rules apply to installations in explosive or flammable atmospheres. Do not install the product or any auxiliary equipment in an explosive zone unless it is rated explosion-proof or intrinsically-safe. If the product is rated explosion-proof or intrinsically-safe, then see the specific explosion-proof information in the safety chapter before taking any further actions.

### General requirements

These requirements apply:

- Use the pump dimensional drawing in order to ensure proper installation.
- In S-, T-, and Z-installations the pump must be equipped with cooling jacket

Before installing the pump, do the following:

- Provide a suitable barrier around the work area, for example, a guard rail.
- Make sure that equipment is in place so that the unit cannot roll or fall over during the installation process.
- Check the explosion risk before you weld or use electric hand tools.
- Check that the cable and cable entry have not been damaged during transport.
- Always remove all debris and waste material from the sump, inlet piping, and discharge connection, before you install the pump.
- Always check the impeller rotation before lowering the pump into the pumped liquid.

---

### **NOTICE:**

Do not run the pump dry.

---

### **NOTICE:**

Never force piping to make a connection with a pump.

### Authority regulation

Vent the tank of a sewage station in accordance with local plumbing codes.

## Fasteners

- Only use fasteners of the correct size and material.
- Replace all corroded or damaged fasteners.
- Make sure that all the fasteners are correctly tightened and that there are no missing fasteners.

EN

## 4.2 Install with P-installation

In the P-installation, the pump is installed on a stationary discharge connection, and operates either completely or partially submerged in the pumped liquid. These requirements and instructions only apply when the installation is made according to the dimensional drawing.

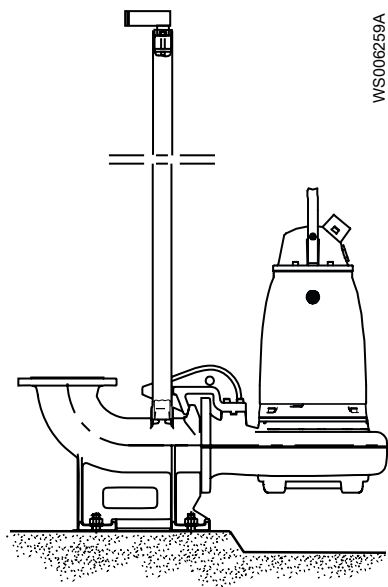

Figure 5: P-installation

These items are required:

- Guide bars
  - Guide bar bracket for attaching the guide equipment to the access frame or to the upper part of the sump
  - Level regulators or other control equipment for start, stop, and alarm
  - Cable holder for holding the cable and regulating the height of the level regulators
  - Access frame (with covers) to which the upper guide bar bracket and cable holder can be attached
  - Discharge connection for connecting the pump to the discharge line  
The discharge connection has a flange which fits the pump housing flange and a bracket for attaching the guide equipment.
  - Fasteners for the discharge connection
  - Anchor bolts
1. Run a cable between the sump and the stator and monitoring equipment.  
Make sure that the cable is not sharply bent or pinched.
  2. Install the access frame:
    - a) Place the access frame in position and align it horizontally.
    - b) Grout the frame in place.
  3. Grout the anchor bolts in place.  
Be careful when you align and position the discharge connection in relation to the access frame.

4. Place the discharge connection in position, and tighten the nuts.
5. Install the guide bars:
  - a) Secure the guide bars in the bracket.
  - b) Check that the guide bars are placed vertically. Use a level or a plumb line.
6. Connect the discharge pipe to the discharge connection.
7. Prepare for the level regulator:
  - a) Bolt the cable holder to the access frame.
  - b) Attach the level regulator cable to the cable holder and adjust the height of the level regulator.
  - c) Protect bolts and nuts with a corrosion-preventive compound.
8. Lower the pump along the guide bars.
9. Secure the motor cable:
  - a) Fasten the permanent lifting device to the pump and to the access frame. For example, you can use a stainless-steel lifting chain with shackles.
  - b) Fasten the cable to the cable holder.  
Make sure that the cable cannot be sucked into the pump inlet or that it is neither sharply bent, or pinched. Support straps are required for deep installations.
  - c) Connect the motor cable and the starter and monitoring equipment according to the separate instructions.  
Make sure that the impeller rotation is correct. For more information, see [Check the impeller rotation](#) on page 51.

Clean all debris from the sump before starting the pump.

### 4.3 Install with S-installation

In the S-installation, the pump is transportable and intended to operate either completely or partially submerged in the pumped liquid. The pump is equipped with a connection for hose or pipe and stands on a base stand.

These requirements and instructions only apply when the installation is made according to the dimensional drawing. For information about the different installation types, see Parts List.

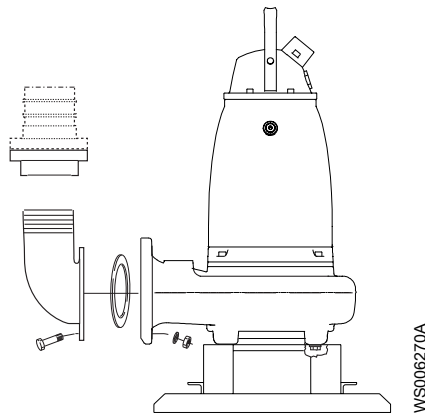

Figure 6: S-installation

1. Run the cable so that it has no sharp bends. Make sure that it is not pinched, and cannot be sucked into the pump inlet.
2. Connect the discharge line.
3. Lower the pump into the sump.
4. Place the pump on the base and make sure it cannot fall over or sink.

Alternatively, the pump can be suspended with chains just above the sump bottom. Make sure that the pump cannot rotate at start-up or during operation.

5. Connect the motor cable and the starter and monitoring equipment according to the separate instructions.

Make sure that the impeller rotation is correct. For more information, see [Check the impeller rotation](#) on page 51.

EN

## 4.4 Install with Z-installation

In the Z-installation, the pump is installed in a horizontal position on a support stand in a dry well next to the wet well, and a bell-mouth is connected to the inlet pipe. These requirements and instructions are for Z-installations that comply to the dimensional drawing.

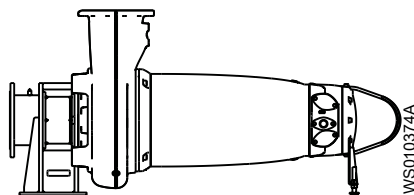

Figure 7: Z-installation, standard

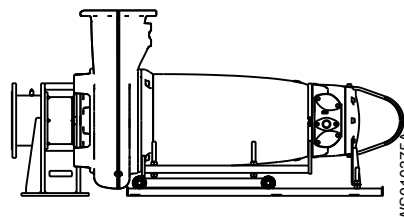

Figure 8: Z-installation, service cart

These items are required:

- Support stand and anchor bolts for anchoring the pump to a base
- Shut-off valves that allow you to remove the pump from service

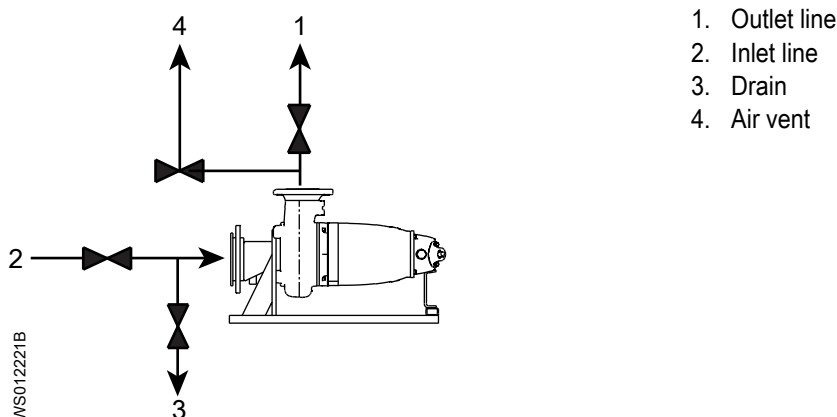

Figure 9: Shutoff and air vent valves (generic pump shown)

- Air vent on the outlet side between the pump and the check valve
- Level regulators or other control equipment for start, stop, and alarm

### NOTICE:

The risk of freezing is particularly high in T- or Z-installations.

1. Fasten the pump:
  - a) Use the anchor bolts to bolt the support stand to the concrete base.
  - b) Bolt the pump to the support stand and the suction connection.
2. Make sure that the pump is vertical for the T-installation or horizontal for the Z-installation.
3. Connect the suction line and discharge line.
 

If the discharge is rotated, rotate the drive unit so that the inspection and drain plugs face downwards.

4. Connect the motor cable and the starter and monitoring equipment according to the separate instructions.

Make sure that the impeller rotation is correct. For more information, see [Check the impeller rotation](#) on page 51.

5. Make sure that the weight of the pump does not put strain on the piping.

## 4.5 Install with T-installation

In the T-installation, the pump is installed in a vertical position in a dry well next to the wet well. These requirements and instructions only apply when the installation is made according to the dimensional drawing.

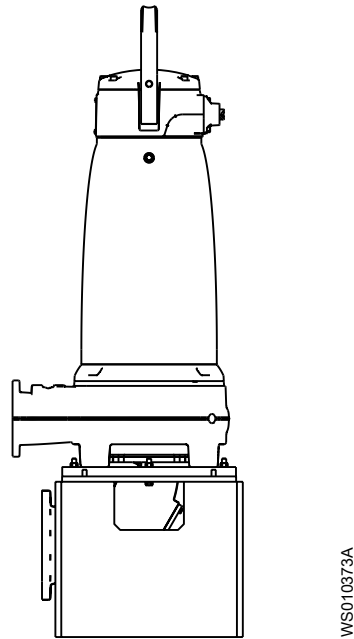

These items are required:

- Support stand and anchor bolts for anchoring the pump to a base
- Inlet elbow for connecting the suction line and discharge line
- Shut-off valves that allow you to remove the pump from service

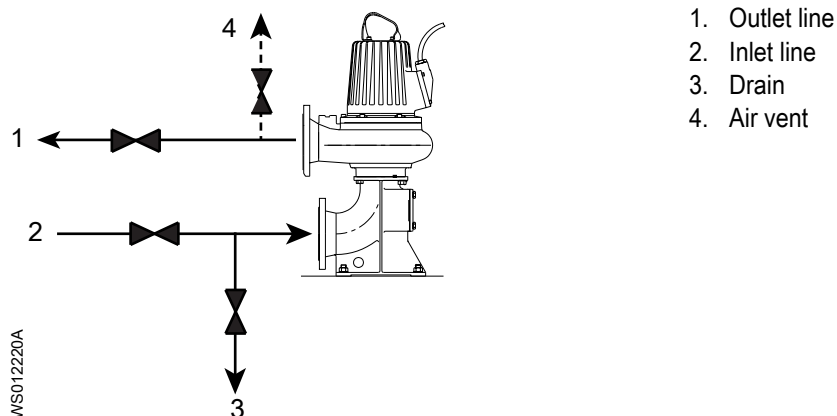

Figure 10: Shutoff and air vent valves (generic pump shown)

- Air vent on the discharge side between the pump and the check valve
- Level regulators or other control equipment for start, stop, and alarm

### NOTICE:

The risk of freezing is particularly high in T- or Z-installations.

1. If the stand is used, then go to [Install with the stand](#) on page 23.
2. Fasten the pump:
  - a) Use the anchor bolts to bolt the support stand to the concrete base.
  - b) Bolt the pump to the support stand and the suction connection.
3. Make sure that the pump is vertical for the T-installation.
4. Connect the suction line and discharge line.
5. Connect the motor cable and the starter and monitoring equipment according to the separate instructions.
 

Make sure that the impeller rotation is correct. For more information, see [Check the impeller rotation](#) on page 51.
6. Make sure that the weight of the pump does not put strain on the piping.

## 4.6 Install with the stand



### WARNING: Crush Hazard

Always lift the unit by its designated lifting points.  
Use suitable lifting equipment and ensure that the product is properly harnessed.  
Wear personal protective equipment.  
Stay clear of cables and suspended loads.

### Major parts

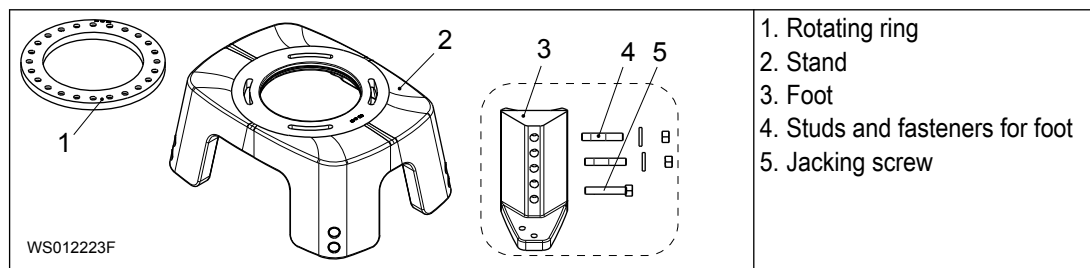

For information on dimensional drawings and fasteners, see the following:

- [Stand dimensional drawings](#) on page 31
- [Fasteners](#) on page 31

### Remove the drive unit before lifting

#### NOTICE:

Never lift the complete pump together with the stand. The drive unit must be removed.

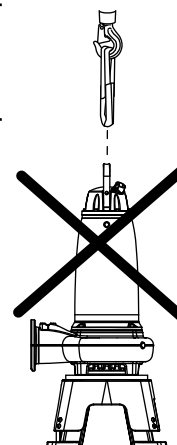

WS012224C

### Changing the height of the stand

If the height of the stand is changed, then the floor bolts must be moved.

## 4.6.1 Find the height setting from the inlet (X)

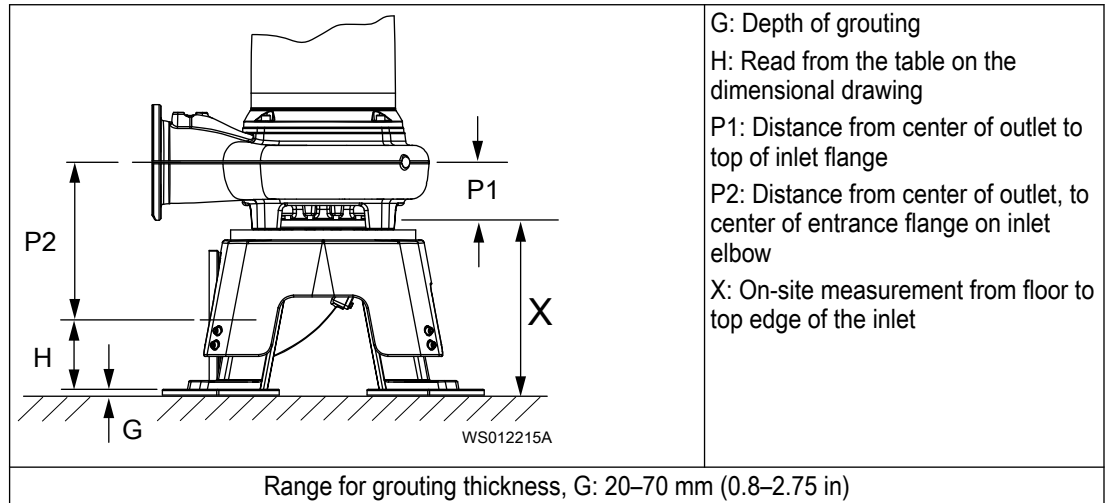

1. Measure X.
2. Read P1 and P2 from the dimensional drawing.
3. Calculate H+G by using the following:  $H+G = X + P1 - P2$
4. Continue with [Read the height setting from the table](#) on page 24.

## 4.6.2 Find the height setting from the outlet (Y)

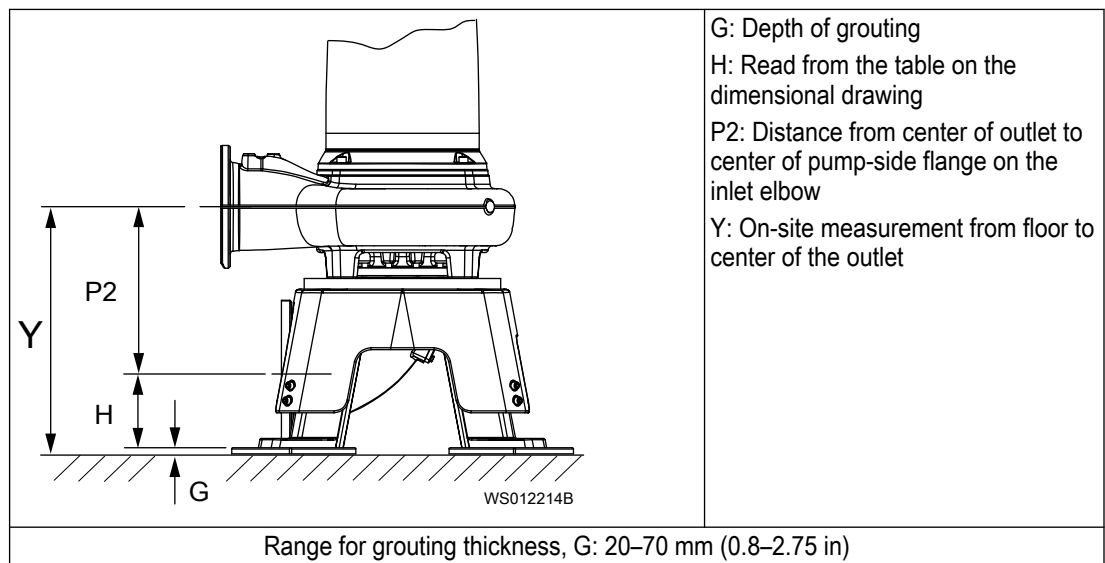

1. Measure Y.
2. Read P2 from the dimensional drawing.
3. Calculate H+G by using the following:  $H+G = Y - P2$
4. Continue with [Read the height setting from the table](#) on page 24.

## 4.6.3 Read the height setting from the table

Use the table on the pump-specific dimension drawing.

1. Use the column H+G to identify the applicable row.
2. Read H and the height setting in the selected row. See the following example.

Height setting	H	H+G
1	245	265–315
2	295	315–365
3	345	365–415
4	395	415–465
5	445	465–515
6	495	515–565

WS012216B

Figure 11: Read height settings on dimensional drawing

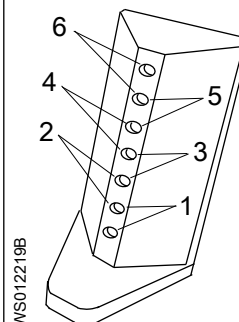
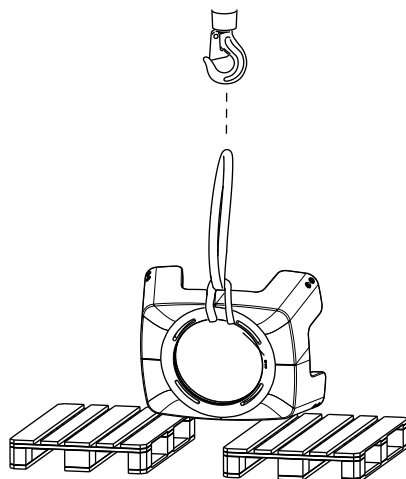

Figure 12: Height settings on foot

3. Calculate the grout thickness:  $G = H+G - H$   
The minimum grout thickness is 20 mm (0.8 in).

#### 4.6.4 Assemble the stand

1. If the stand has been delivered with the rotation ring packed on top, then remove the ring.
2. Position two wooden blocks or pallets on the floor, approximately 30 cm (12 in) apart.  
The wooden blocks or pallets must have the same height, and be able to support the weight of the stand.
3. Position the stand upside-down on the two pallets or blocks:
  - a) Attach a lifting strap around the long end of the stand.
  - b) Connect the lifting strap to the lifting equipment.
  - c) Lift the stand carefully and move it over the pallets or blocks.
  - d) Lower the stand until it rests equally on the two pallets.



- e) Continue lowering until the stand is upside-down on the blocks or pallets.

EN

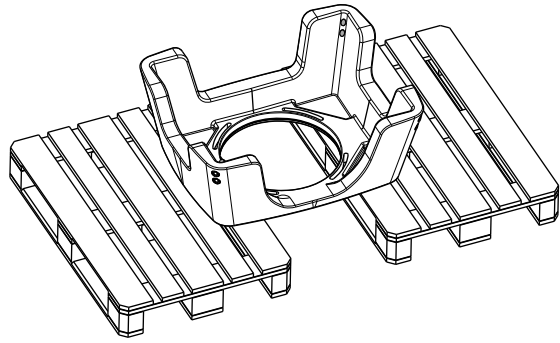

4. Attach the feet:

- a) Identify the pair of holes in the foot for the calculated height setting. See [Read the height setting from the table](#) on page 24.
- b) Insert two studs in the selected holes of the foot. Tighten the studs.

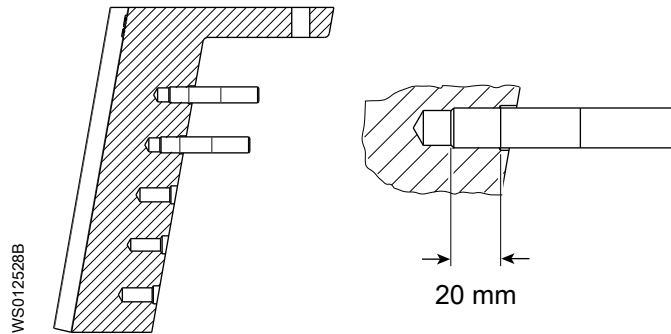

- c) Attach a lifting eye and the lifting equipment to a foot. Lift the foot.
- d) Lower the foot until the two studs in the foot are aligned with the holes in the stand.
- e) Carefully fit the foot with the studs through the holes in the stand.

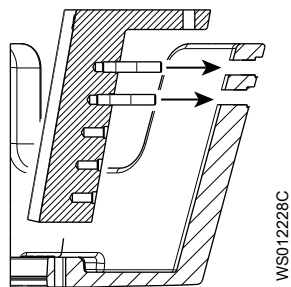

- f) Attach a washer and M16 nut to each stud, and tighten.  
Tightening torque: 187 Nm

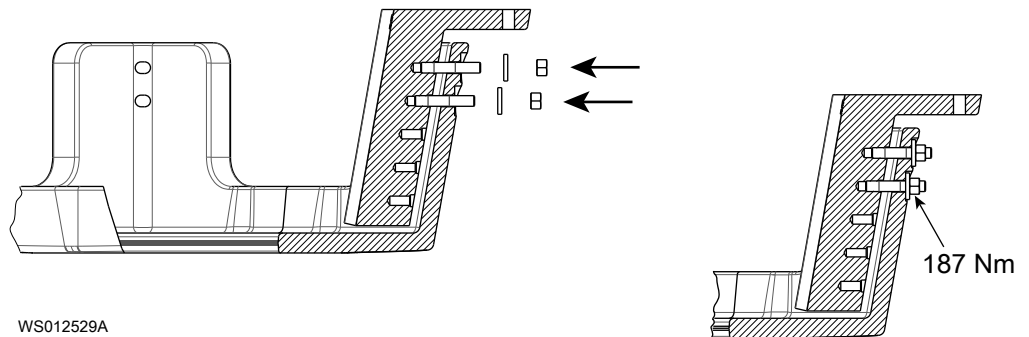

- g) Follow this procedure to install the other three feet.
5. Turn the stand right-side up:

- a) Attach a lifting strap to the long side of the stand.
- b) Lift the stand.  
The stand turns during the lift.
- c) Set the stand down on the edge of two feet.
- d) Push the stand over and continue lowering with the lifting equipment.

#### 4.6.5 Install the anchor bolts

1. Lift the assembled stand:
  - a) Attach two lifting slings to the stand. See the following figure.

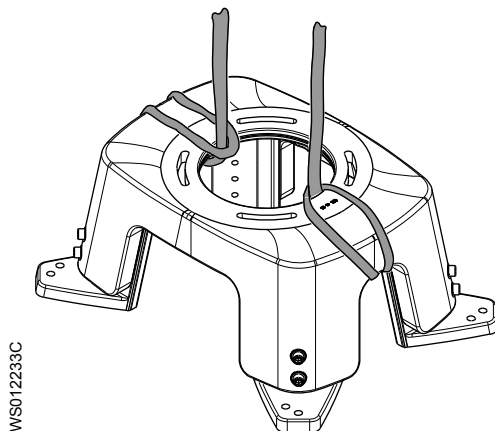

- b) Lift the stand.
2. Lower the stand into position.

Make sure that the stand is oriented so that the inlet elbow can fit through the correct side. See the arrow in the following figure.

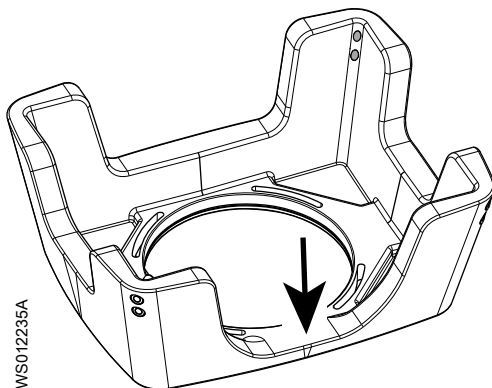

3. Mark where the holes are drilled, by using the feet as template.  
Use the non-threaded holes for the anchor bolts
4. Drill holes for the M16 (5/8 ") bolts, and install the anchor bolts.
  - Follow the instructions given by the manufacturer of the anchor bolts.
  - Make sure that the anchor bolts are long enough to accommodate the grouting.
5. Remove the assembled stand.
6. Remove the lifting slings.

#### 4.6.6 Attach the pump housing to the stand

Make sure that pressure in the cooling jacket is relieved, before disconnecting the drive unit bolts.

**CAUTION: Compressed Gas Hazard**

Air inside the chamber may cause parts or liquid to be propelled with force. Be careful when opening. Allow the chamber to de-pressurize before removal of the plug.

EN

1. Remove the bolts which attach the drive unit to the pump housing, and remove the drive unit.
2. Turn the pump housing upside-down.
3. Install the rotating ring on the pump housing feet:
  - a) Lift the rotating ring into position.
  - b) If the rotating ring has four notches or holes on the inner edge, then align the pump housing feet with the four holes.

See the arrows in the following figure.

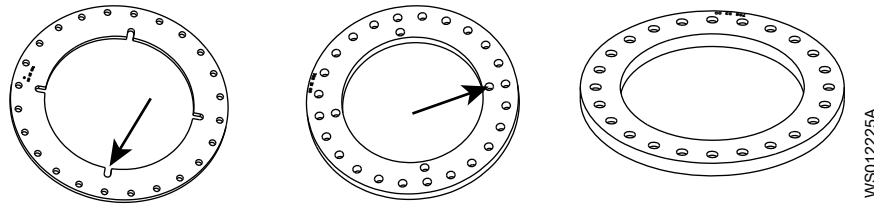

- c) Attach the rotating ring to the pump housing with four bolts.
4. Turn the pump housing rightside-up.
5. Attach four lifting eyes to the pump housing. Attach lifting slings to the lifting eyes.
6. Lift the pump housing and rotating ring, and lower it onto the stand.  
Make sure that the pump housing is oriented correctly to the inlet.
7. Fasten the rotating ring to the stand with four bolts.

#### 4.6.7 Install the stand on the anchor bolts

If the installation of grout is necessary, make sure that all preparations are done before lifting the pump and stand assembly into position. Follow the grout manufacturers recommendations.

1. Lift the pump housing, rotating ring, and stand by using the four lifting eyes in the pump housing.

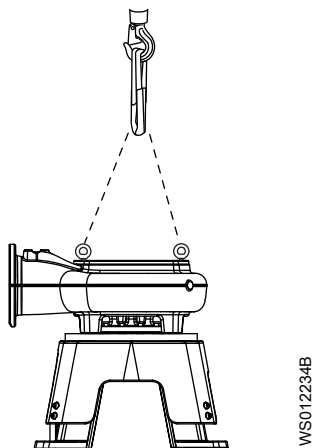

2. Insert the jacking screws into the stand.
3. Position levelling pads for each jacking screw.

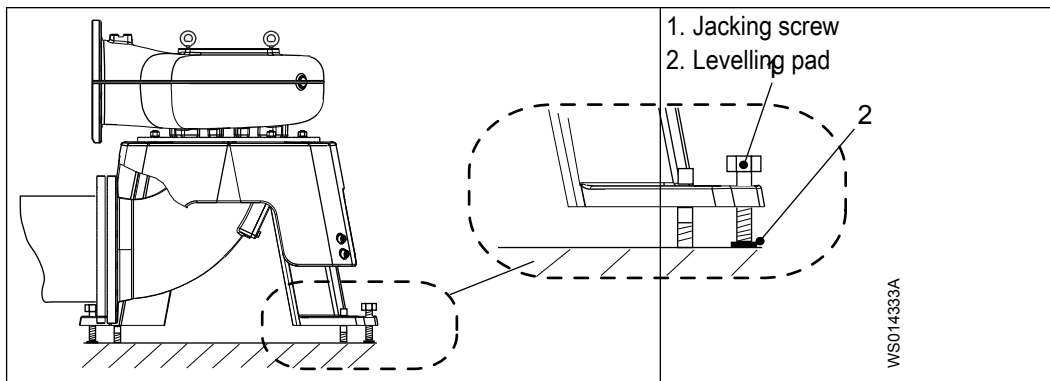

4. Adjust the jacking screws to height G, grout thickness. See [Read the height setting from the table](#) on page 24.
5. Lower the stand onto the anchor bolts.

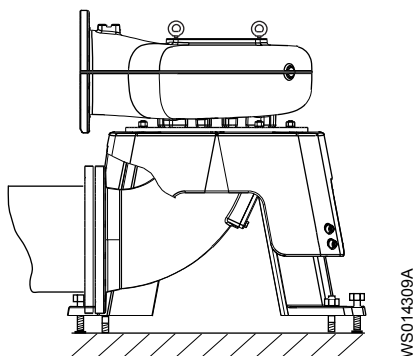

6. Level and align the stand by using the jacking screws.
7. Apply a bond breaker to the jacking screw threads that is under the stand.  
The bond breaker allows the jacking screw to be easily removed from the grout.
8. Connect the inlet elbow or inlet pipe to the pump housing.  
Make sure that the gasket is in position. See the following figure.

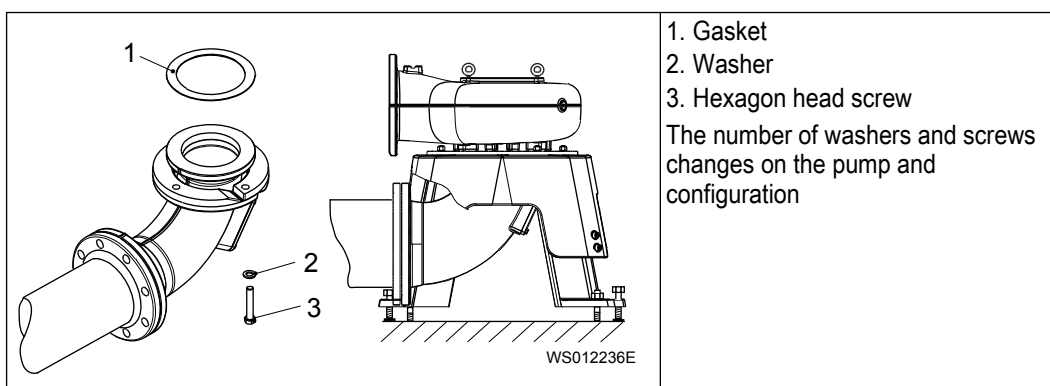

9. Connect the pump outlet piping.
10. Apply the grout under each foot.

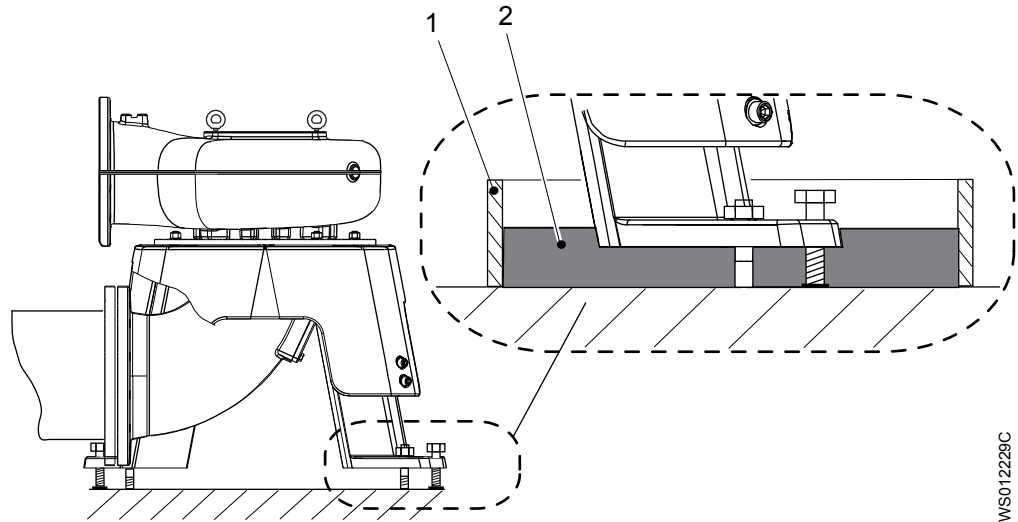

1. Form for the grout
2. Grout

a) Allow the grout to set to at least 20 Mpa (2900 psi) of compression strength.

For more information, see the grout manufacturer data sheet.

11. Remove the jacking screws.
12. Filling the jacking screw holes with grout.
  - a) Allow the grout to set.
13. Install the anchor nut on the top side of each foot.

#### 4.6.8 Install the drive unit on the pump housing

1. Remove the lifting slings and lifting eyes from the pump housing.
2. Lift the drive unit onto the pump housing.
3. Attach the drive unit to the pump housing with four screws, and tighten to the correct torque.
4. Continue with the installation of the pump.

WS012229C

## 4.6.9 Fasteners

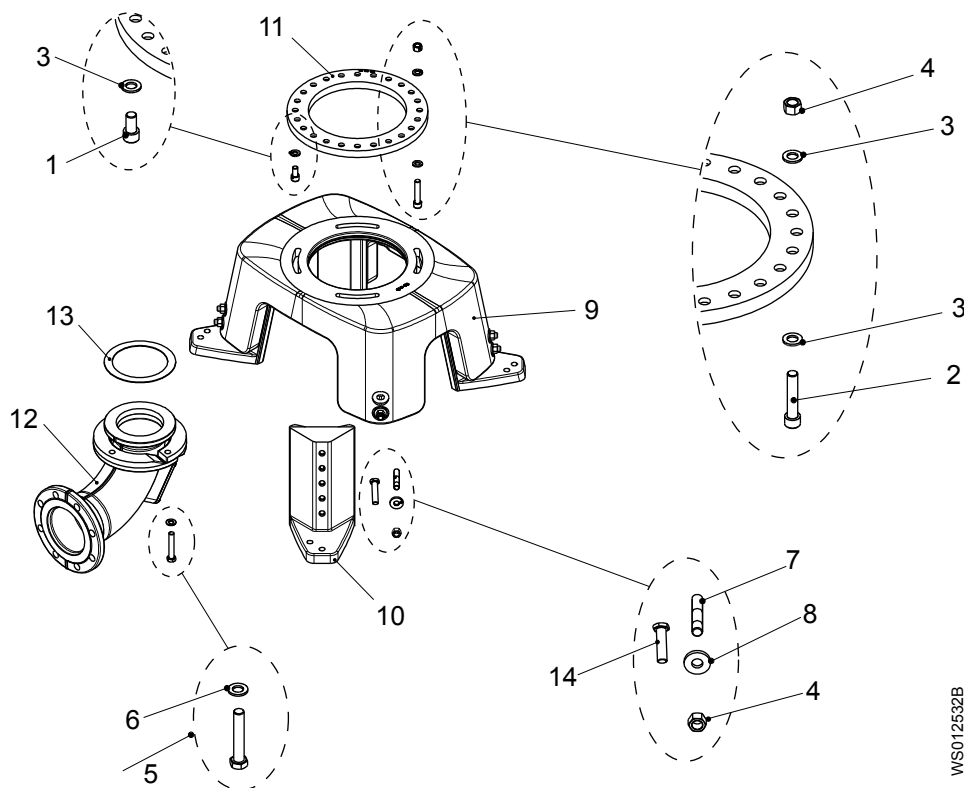

1. Hex socket head screw. See the following tables.
2. Hex socket head screw. See the following tables.
3. Plain washer. Part number 823578.
4. Hex nut. Part number 822337.
5. Hex head screw. See the following table.
6. Plain washer. See the following table.
7. Stud. See the following table.
8. Plain washer. Part number 851045.
9. Stand
10. Foot
11. Ring
12. Suction inlet elbow. Not included.
13. Gasket
14. Jacking screw

WS012532B

Table 1: 3315

Pressure Class	Poles	1 Qty: 4	2 Qty: 4	5 (Qty)	6 (Qty)	7 Qty: 8
HT		830370	802298	815584 (4X)	823579 (4X)	809560
MT		830370	802298	815583 (12X)	823579 (12X)	809560
LT	6	830370	802298	814965 (16X)	823579 (16X)	809560
LT	8	830370	802298	814965 (16X)	823579 (16X)	809560

## 4.6.10 Stand dimensional drawings

The stand dimensional drawings show the pump and stand dimensions that are needed for the installation. The drawings are customized for the different pump configurations. Use the following table to select the drawing.

Table 2: 3315

Pressure Class	Poles	Version Codes	Pump Outlet	Pump Inlet	Suction Inlet	Dimensional Drawing
LT	6	All	DN 300	DN 350	DN 400	8412900
LT	8	All	DN 350	DN 350	DN 400	8413000
MT		All	DN 250	DN 250	DN 300	8413100

Pressure Class	Poles	Version Codes	Pump Outlet	Pump Inlet	Suction Inlet	Dimensional Drawing
HT		All	DN 150	DN 200	DN 250	8412800

## 4.7 Make the electrical connections

### 4.7.1 General precautions



#### **DANGER: Electrical Hazard**

Before starting work on the unit, make sure that the unit and the control panel are isolated from the power supply and cannot be energized. This applies to the control circuit as well.



#### **WARNING: Electrical Hazard**

Risk of electrical shock or burn. A certified electrician must supervise all electrical work. Comply with all local codes and regulations.



#### **WARNING: Electrical Hazard**

There is a risk of electrical shock or explosion if the electrical connections are not correctly carried out, or if there is fault or damage on the product. Visually inspect equipment for damaged cables, cracked casings or other signs of damage. Make sure that electrical connections have been correctly made.



#### **WARNING: Crush Hazard**

Risk of automatic restart.



#### **CAUTION: Electrical Hazard**

Prevent cables from becoming sharply bent or damaged.

#### **NOTICE:**

Leakage into the electrical parts can cause damaged equipment or a blown fuse. Keep the cable ends dry at all times.

### Requirements

These general requirements apply for the electrical installation:

- If the pump will be connected to the public mains, then the supply authority must be notified before installing the pump. When the pump is connected to the public power supply, it can cause flickering of incandescent lamps when started.
- The mains voltage and frequency must agree with the specifications on the data plate. If the pump can be connected to different voltages, then follow the specified voltage on the yellow sticker close to the cable entry.
- If the operation can be intermittent, such as S3 periodic duty, then the pump must be supplied with monitoring equipment supporting such operation.
- If stated on the data plate, then the motor is convertible between different voltages.
- The thermal contacts or thermistors must be in use.
- For FM-approved pumps, a leakage sensor must be connected and in use to meet approval requirements.

## Motor and short-circuit protection

### NOTICE:

A qualified electrician must select the size of motor protection breakers and fuses. The size must be chosen for the specific motor data such as rated current and starting current.

It is important that the short-circuit protection is not over-dimensioned. Over-dimensioned fuses or motor protection breakers decrease the protection for the motor.

- The fuse rating and the cables must be in accordance with the local rules and regulations.
- The fuses and circuit breakers must have the correct rating.
- The pump overload protection must be connected and set to the rated current.

The starting current in direct-on-line start can be up to six times higher than the rated current.

For more information, see the data plate and if applicable, the cable chart for the rated current.

## Cables

When cables are installed, these requirements must be followed:

- The cables must be in good condition, not have any sharp bends, and not be pinched.
- The cables must not be damaged and must not have indentations.
- The cables must not be embossed at the cable entry.
- The cable entry seal sleeve and washers must conform to the outer diameter of the cable.
- The minimum bend radius must not be smaller than the accepted value.
- If a cable is reused, a short piece at the end must be peeled off when the cable is refitted. This action is necessary so that the seal sleeve of the cable entry does not close around the cable at the same point again. If the outer jacket of the cable is damaged, then the cable must be replaced.

Contact a sales or authorized service representative.

- The voltage drop in long cables must be considered. The rated voltage of the drive unit is the voltage that is measured at the cable connection point in the pump.
- If a variable frequency drive (VFD) is used, the screened cable must be used according to the European CE and EMC requirements. For more information, contact a sales or authorized service representative.
- The cable length must be long enough for maintenance work.
- For SUBCAB™ cables, the twisted pair copper foil must be trimmed.
- All unused conductors must be insulated.

### 4.7.2 Grounding (earthing)

Grounding (earthing) must be done in compliance with all local codes and regulations.



#### **DANGER: Electrical Hazard**

All electrical equipment must be grounded (earthed). Test the ground (earth) lead to verify that it is connected correctly and that the path to ground is continuous.



#### **WARNING: Electrical Hazard**

Risk of electrical shock. The ground (earth) lead must be sufficiently longer than the phase leads to make sure that the ground lead is the last to become disconnected if the cable is jerked loose.

**WARNING: Electrical Hazard**

Risk of electrical shock or burn. You must connect an additional ground- (earth-) fault protection device to the grounded (earthed) connectors if persons are likely to come into contact with liquids that are also in contact with the pump or pumped liquid.

## 4.7.3 Prepare the SUBCAB™ cables

This section applies to SUBCAB™ cables with twisted-pair control conductors.

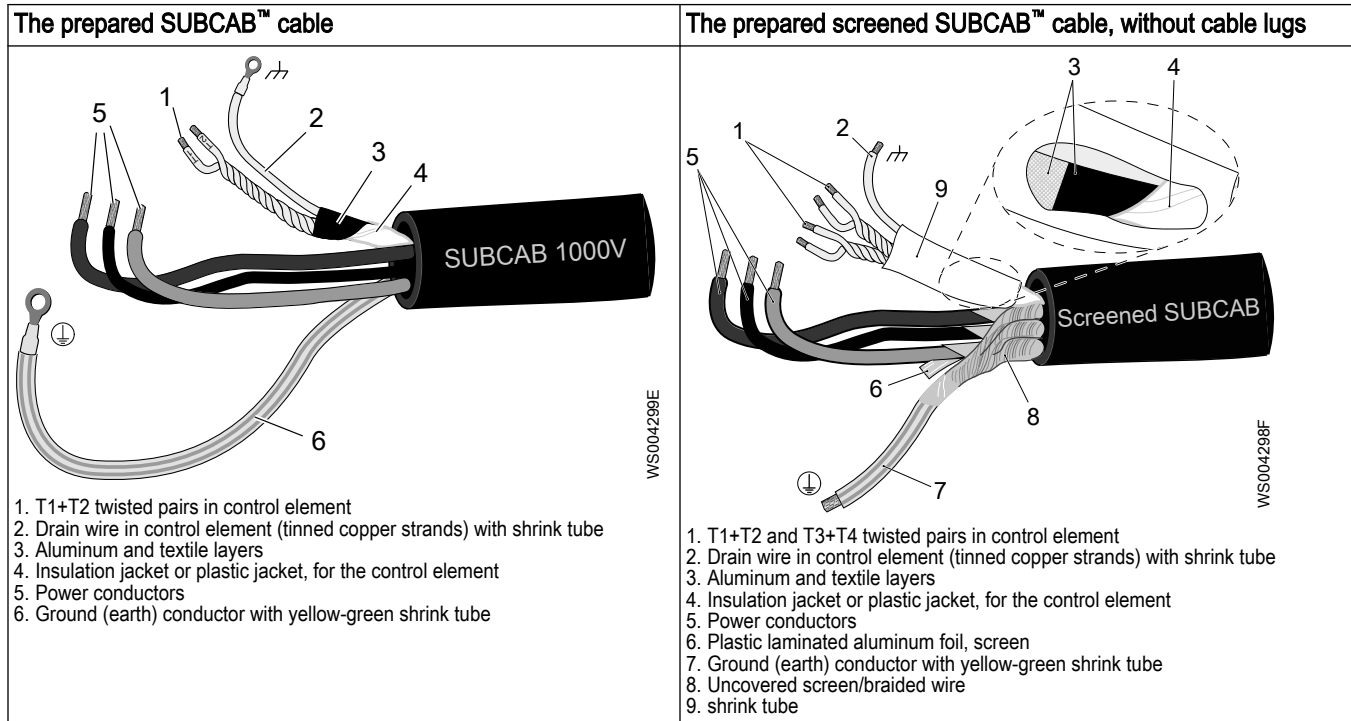

1. Peel off the outer jacket at the end of the cable.
2. Prepare the control element:
  - a) Peel the insulation jacket or plastic jacket.
  - b) Peel the aluminum and textile layers.

The aluminum foil is a conductive screen. Do not peel more than necessary, and remove the peeled foil.

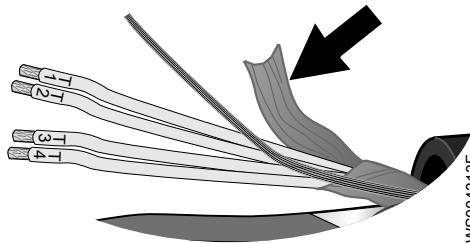

Figure 13: Aluminum foil on the control element.

- c) Put a white shrink tube over the drain wire.
  - d) Twist T1+T2 and T3+T4.
  - e) Put a shrink tube over the control element.

Make sure that the conductive aluminum foil and drain wire are covered.
3. Prepare the ground (earth) conductor of the SUBCAB™ cable:

- a) Peel the yellow-green insulation from the ground (earth) conductor.
  - b) Check that the ground (earth) conductor is at least 10% longer than the phase conductors in the cabinet.
  - c) If applicable, put a cable lug on the ground conductor.
4. Prepare the ground (earth) conductor of the screened SUBCAB™ cable:
- a) Untwist the screens around the power conductors.
  - b) Twist all power conductor screens together to create a ground (earth) conductor.
  - c) Put a yellow-green shrink tube over the ground (earth) conductor.  
Leave a short piece uncovered.
  - d) Check that the connected ground (earth) conductor has sufficient slack. The conductor must stay connected even if the power conductors are pulled loose.
5. Prepare the power conductors:
- a) Remove the aluminum foil around each power conductor.
  - b) Peel the insulation from each power conductor.
6. Prepare the ends of the ground (earth) conductor, the power conductors, and the drain wire:

Connection type	Action
Screw	Fit cable lugs to the ends.
Terminal block	Fit end sleeves or leave the ends as they are.

#### 4.7.4 Connect the motor cable to the pump

If the motor cable is not already connected to the pump, then connect it by following this procedure.

##### NOTICE:

Leakage into the electrical parts can cause damaged equipment or a blown fuse. Keep the end of the motor cable dry at all times.

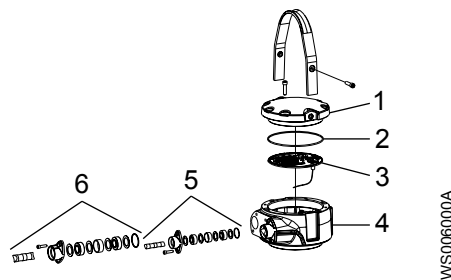

1. Cover
2. O-ring
3. Terminal plate with terminal board
4. Connection housing
5. Monitoring cable entry
6. Motor cable entry

For more information about the cable entry, see the Parts List.

EN

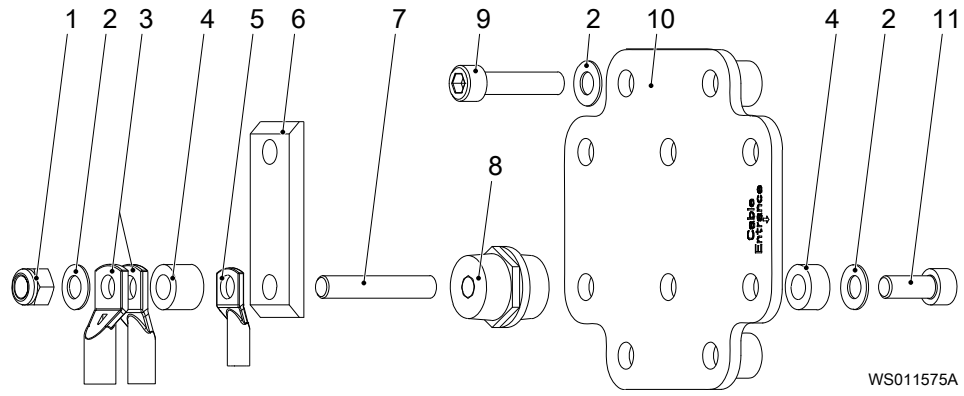

- 1. Nut
  - 2. Disc spring
  - 3. Cable lug for phase lead
  - 4. Standoff
  - 5. Cable lug for stator lead
  - 6. Closing link, generic illustration
  - 7. Stud
- Tightening torque: 22.0±2.2 Nm (16.2±1.6 lbf-ft)
- 8. Insulator
  - 9. Screw for the terminal board
  - 10. Terminal board 834 57 xx
  - 11. Screw for insulator
- Tightening torque: 44.0±4.4 Nm (32.5±3.2 lbf-ft)

Figure 14: Terminal board 834 57 xx

1. Remove the cover and the O-ring from the connection housing.
2. Replace the terminal board, if necessary:
  - a) Remove all connections to the old terminal board. Remove the old terminal board.
  - b) Examine the new terminal board assembly. If applicable, then tighten to the correct torques.
  - c) Install the terminal board.
 

Tightening torque: 44.0±4.4 Nm (32.5±3.2 lbf-ft)
  - d) Apply the closing links.
3. Install cable lugs and insulate the cable ends of the power leads:

Insulation option	Actions
Shrink hose 94 03 30 or 95 00 32	<ol style="list-style-type: none"> <li>1. Fit 50 mm (2 in) of a shrink hose with the correct dimensions over the cable.</li> <li>2. Move the shrink hose away from the cable end.</li> <li>3. Crimp the cable lug on the cable end. Use calibrated crimp tools according to the specified standard for the cable lug.</li> <li>4. Push the shrink hose over the cable lug as far as possible. Use heat to shrink the shrink hose over the cable lug and the cable end.</li> </ol>
Self-vulcanizing tape 94 02 62	<ol style="list-style-type: none"> <li>1. Crimp the cable lug on the cable end. Use calibrated crimp tools according to the specified standard for the cable lug.</li> <li>2. Stretch the self-vulcanizing tape until the oval markings become circular.</li> <li>3. Apply the tape with at least 50% overlap for every turn.</li> <li>4. Apply the tape over the cable lug and over at least 30 mm (1.2 in) of the exposed cable.</li> </ol>

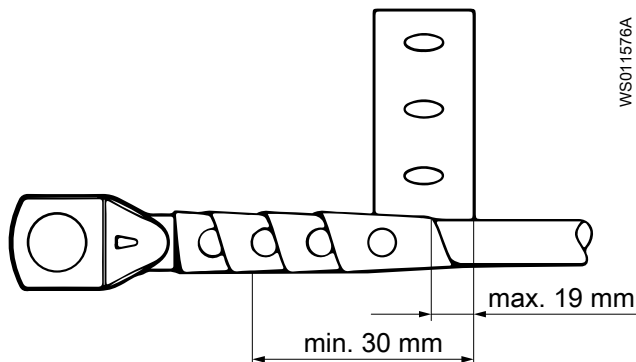

Figure 15: Application of self-vulcanizing tape

4. Examine the data plate to see which connections are required for the power supply.
5. Arrange the connections to the terminal board in accordance with the required power supply.
6. Connect the mains leads: L1, L2, L3, and ground (earth). See the applicable cable chart. The ground (earth) lead must be longer than the phase leads in the junction box of the pump. The following table shows how much extra length is required for the ground (earth) lead.

Pump	Extra length required for the ground (earth) lead	
	Millimeters	Inches
3315	150	6.0

- Install the parts in the correct order.
- Make sure that all cable ends point 90° away from the cable entrance.
- Make sure that the chamfers of the cable lugs are turned in the correct directions.
- Make sure that the convex surfaces of the disc springs face the nuts and the screws.
- Tighten the nuts.

Tightening torque:  $35 \pm 3.5$  Nm ( $26 \pm 2.6$  lbf·ft)

Generic illustration

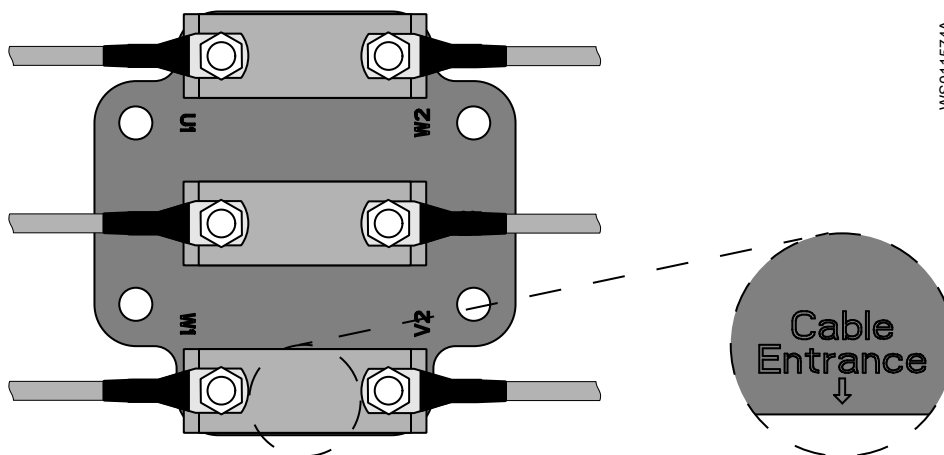

7. Make sure that the pump is correctly connected to ground (earth).
8. Connect the control leads to the applicable terminal board on the terminal plate.
9. Make sure that any thermal contacts incorporated in the pump are properly connected to the terminal board.
10. Install the cover and the O-ring.
11. Fasten the screws on the entrance flange so that the cable insertion assembly bottoms out.

### 4.7.5 Connect the cables to the starter and monitoring equipment

If there are two power cables, then the cable that is connected to T1 and T2 is labeled. If a separate control cable is used, then the control leads in the power cable are never connected.



---

#### **DANGER: Explosion/Fire Hazard**

Special rules apply to installations in explosive or flammable atmospheres. Do not install the product or any auxiliary equipment in an explosive zone unless it is rated explosion-proof or intrinsically-safe. If the product is rated explosion-proof or intrinsically-safe, then see the specific explosion-proof information in the safety chapter before taking any further actions.

---

#### **NOTICE:**

Either thermal contacts or thermistors are incorporated in the pump.

---

#### **NOTICE:**

Thermal contacts must never be exposed to voltages higher than 250 V, breaking current maximum 4 A.

---

#### 4.7.5.1 Connect the sensor leads: MiniCAS II

1. Connect the sensor leads.

Option	Description
Thermal contacts	Connect the T1 and T2 sensor leads to the MiniCAS II.
Thermistors, screened cable	Connect the T1 and T2 sensor leads to the thermistor relay. Connect the T3 and T4 sensor leads to the MiniCAS II.
Thermistors, auxiliary cable	Connect the sensor leads 1 and 2 to the thermistor relay. Connect the sensor leads 3 and 4 to the MiniCAS II.

For more information, see [MiniCAS](#) on page 44.

2. Insulate the unused leads.

#### 4.7.5.2 Connect the auxiliary cable: MAS 711

1. Connect the 12-lead SUBCAB cable, or the 24-lead cable, to the monitoring equipment.  
For more information, see [MAS 711](#) on page 50.
2. Insulate the unused leads.

#### 4.7.5.3 Connect the sensor leads: MAS 801

1. Connect T1 and T2 to the MAS BU.
2. Connect the functional ground to the MAS BU.
3. For Ex-applications, connect T3 and T4 from the thermal contacts or thermistors.

The stator winding temperature sensors are connected to the T3 and T4 terminals on the separate plinth.

Option	Description
Thermal contacts	Connect the thermal contacts in the contactor coil circuit so that the circuit breaks directly. Use an auxiliary relay for the thermal contact status signals.
Thermistors	Connect the leads to a SIL-approved thermistor relay.

For more information, see [MAS 801](#) on page 46.

#### 4.7.5.4 Connect the power leads

1. Connect the mains leads (L1, L2, L3, and ground (earth)) to the starter equipment.

For information about the phase sequence and the color codes of the leads, see Cable charts.

2. Make sure that the warning label is attached to the cable end.

The label is delivered with pumps that are equipped with permanent magnet synchronous motor. If the label is missing, attach the spare label to the cable end.

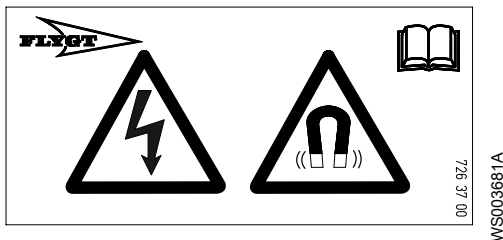

3. Check the functionality of the monitoring equipment:
  - a) Check that the signals and the tripping function work correctly.
  - b) Check that the relays, lamps, fuses, and connections are intact.
 Replace any defective equipment.

## 4.8 Cable charts

### Description

This topic contains general connection information. It also provides cable charts that show connection alternatives for use with different cables and power supply.

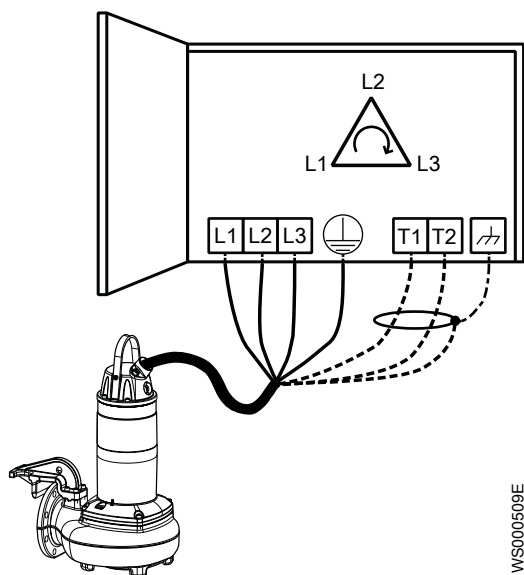
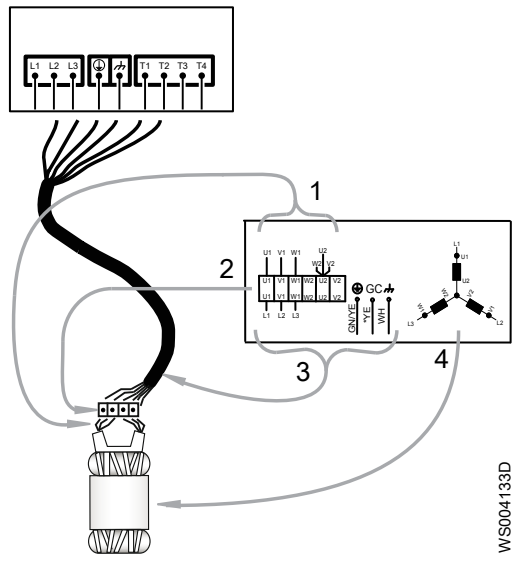

Figure 16: Phase sequence

### 4.8.1 Connection locations

The figures in this section illustrate how to interpret the connection strip symbols.

EN



1. Stator leads
2. Terminal board
3. Power cable leads
4. Stator (internal connection illustrated)

WS004133D

Colors and markings of leads

MOTOR CONNECTION		773 30 00 (REV 5)					
COLORS AND MARKING OF MAIN LEADS							
COLOR STANDARD	STATOR LEAD COLORS		MOTOR CABLE LEAD COLORS AND MARKING				
BK - Black	LV Stators	MV Stators	3 ~	SUBCAB	SUBCAB AWG	SUBCAB S6x95+95+S(4x0.5)	MV cables
BN - Brown	U1 - RD	U - BK	L1	BN	RD	1 WH, 4 WH	BK
BU - Blue	U2 - GN	V - BK	L2	BK	BK	2 WH, 5 WH	BK
GN - Green	V1 - BN	W - BK	L3	GY	WH	3 WH, 6 WH	BK
GN/YE - Green/Yellow	V2 - BU		T1, T2	WH	WH	WH	-
GY - Grey	W1 - YE		T3, T4	WH	WH	WH	-
OG - Orange	W2 - BK		⊕	GN/YE	GN/YE	GN/YE	GN/YE
RD - Red	VOLTAGE DENOMINATIONS		⚡	WH	-	WH	WH
WH - White	LV - Low voltage		GC	-	YE	-	-
YE - Yellow	MV - Medium voltage						

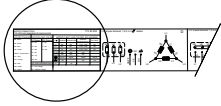

WS004335D

Color code standard

Code	Description
BN	Brown
BK	Black
WH	White
OG	Orange
GN	Green
GN/YE	Green-Yellow
RD	Red
GY	Grey
BU	Blue
YE	Yellow

Connections included

- [Stator leads connection to terminal board](#) on page 41
- [3-phase connection](#) on page 42
- [3-phase connection, screened](#) on page 43

## Stator leads connection to terminal board

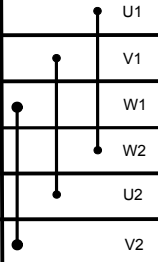
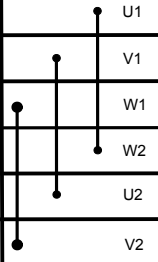
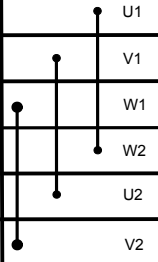
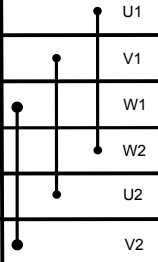
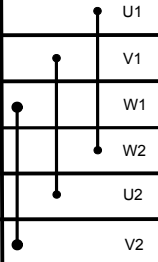
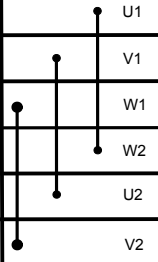
 Terminal board	Stator leads connection to terminal board			
	3 leads Y	6 leads D	6 leads Y	6 leads Y/D
U1	U		U1	U1
V1	V		V1	V1
W1	W		W1	W1
W2	-		W2	W2
U2	-		U2	U2
V2	-		V2	V2

WS007848A

EN

3-phase connection

EN

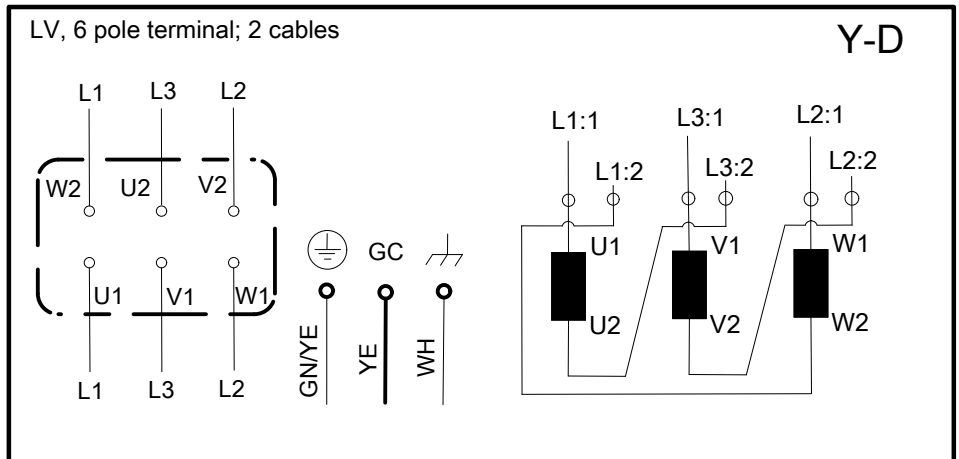
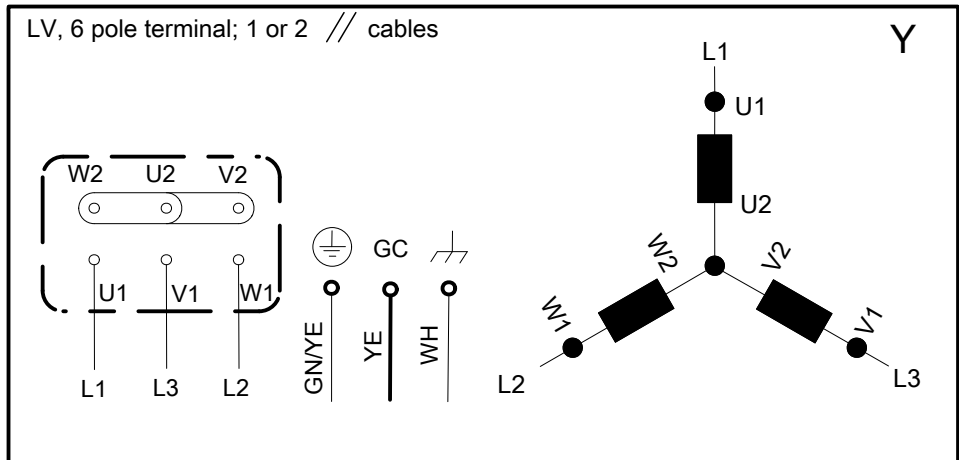
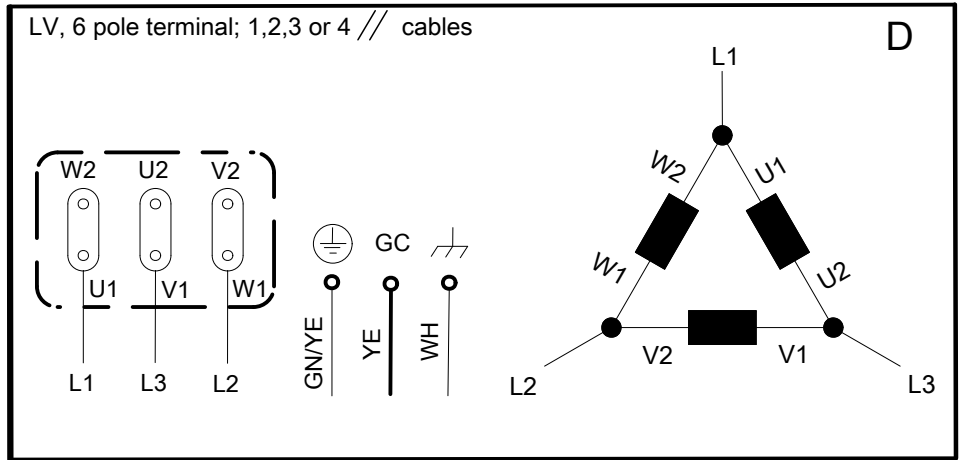

**3-phase connection, screened**

Screened SUBCAB cable without separate ground conductor. The ground conductor is made of stranded ground conductors.

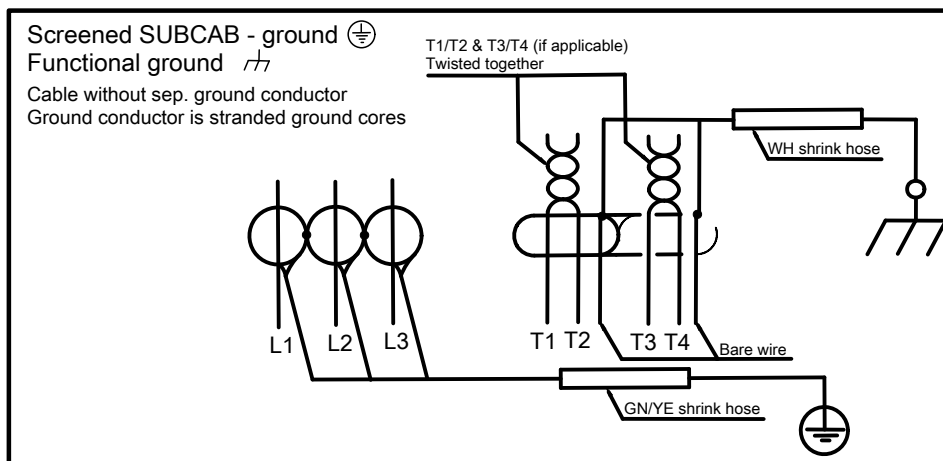

Screened SUBCAB with functional ground. T1 and T2 are twisted together.

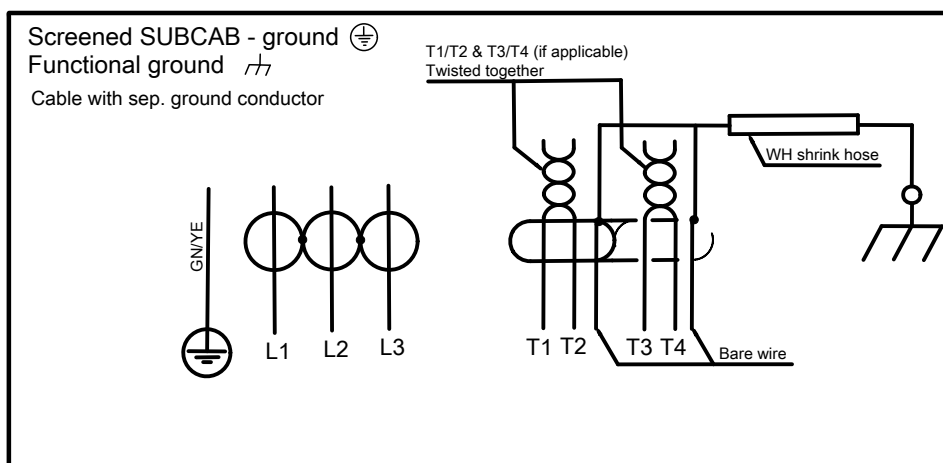

EN

# 4.9 MiniCAS

## Thermal contacts

EN

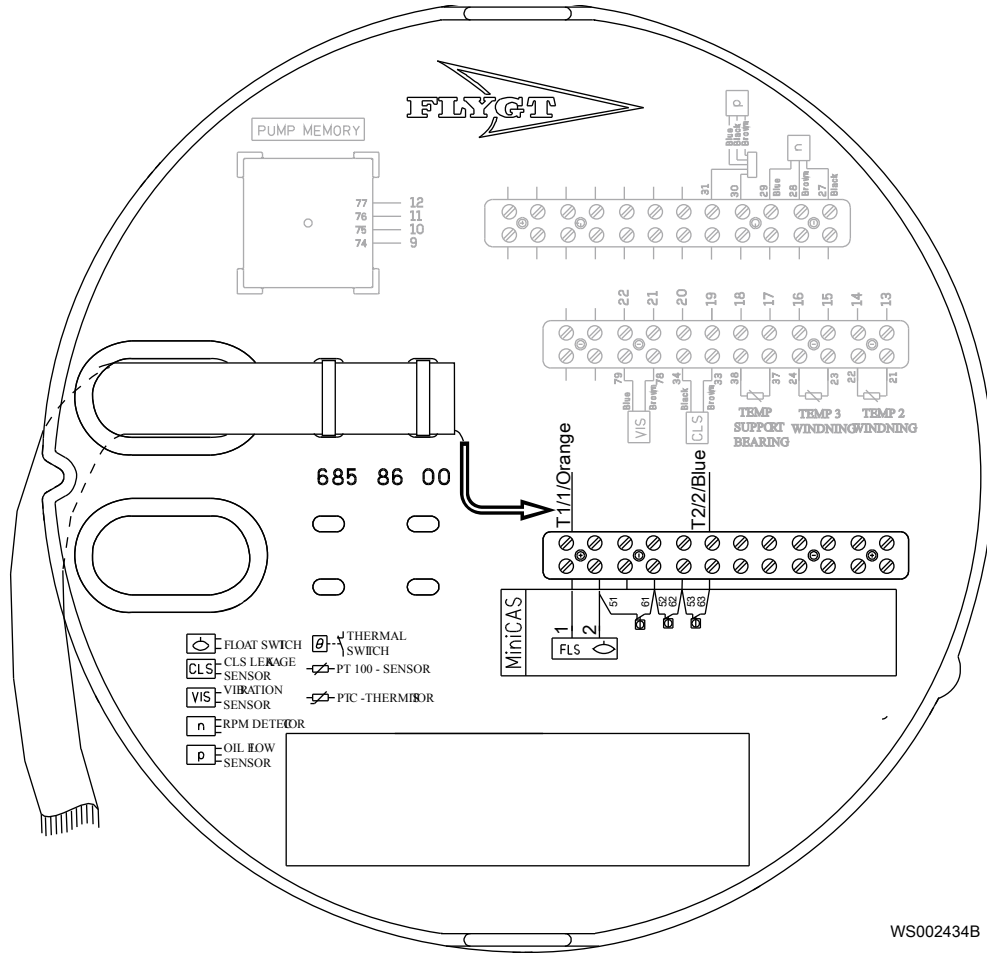

WS002434B

Figure 17: MiniCAS

### Values for FLS 10 and thermal contacts

∞ Ohm

1200 Ohm

430 Ohm

The values have a 10 % tolerance

Overtemperature

OK

Leakage

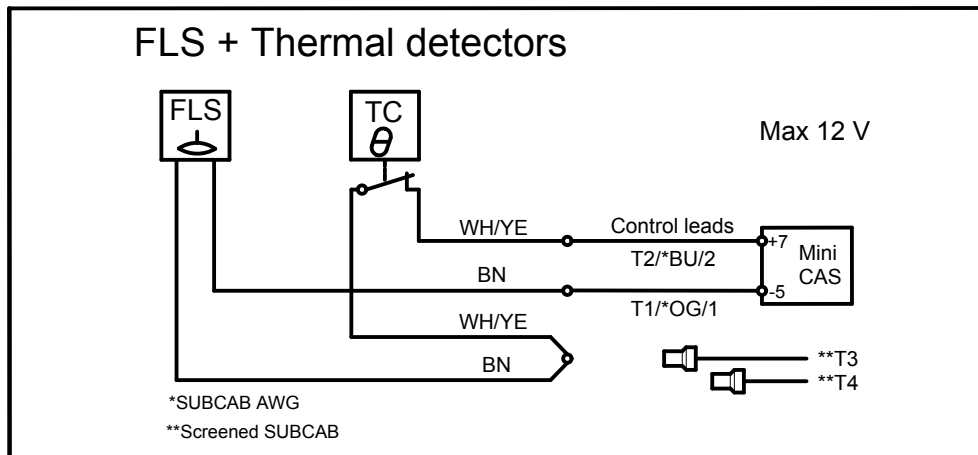

Figure 18: FLS10

Value	Description
$\infty$ ohm	Overtemperature
1200 ohm	OK
430 ohm	Leakage

Thermistors

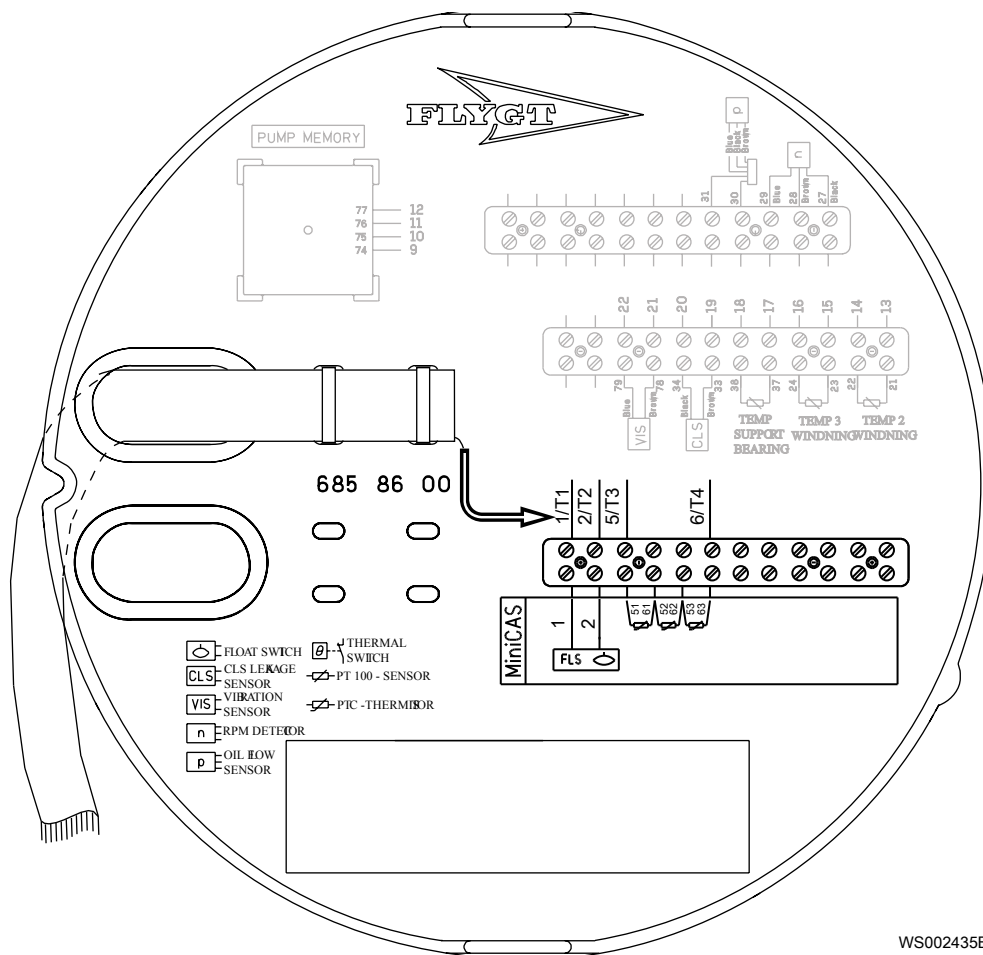

Figure 19: MiniCAS

EN

**Values for FLS 10 and thermistor**

T=25°C (77°F)

T=135°C (275°F) (T<sub>REF</sub>-5°C (9°F))

T=145°C (293°F) (T<sub>REF</sub>+5°C (9°F))

R ≤ 100 Ohm

R ≤ 550 Ohm

R ≤ 1330 Ohm

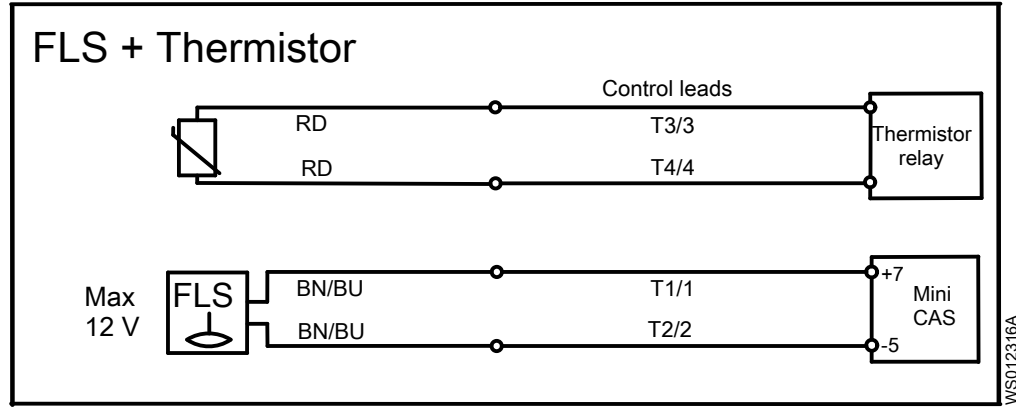

Figure 20: FLS

Value	Description
R ≤ 100 ohm	T=25°C (77°F)
R ≤ 550 ohm	T=135°C (275°F) (T <sub>REF</sub> -5°C (23°F))
R ≤ 1330 ohm	T=145°C (293°F) (T <sub>REF</sub> +5°C (41°F))

### 4.10 MAS 801

Table 3: PEM connections, standard application

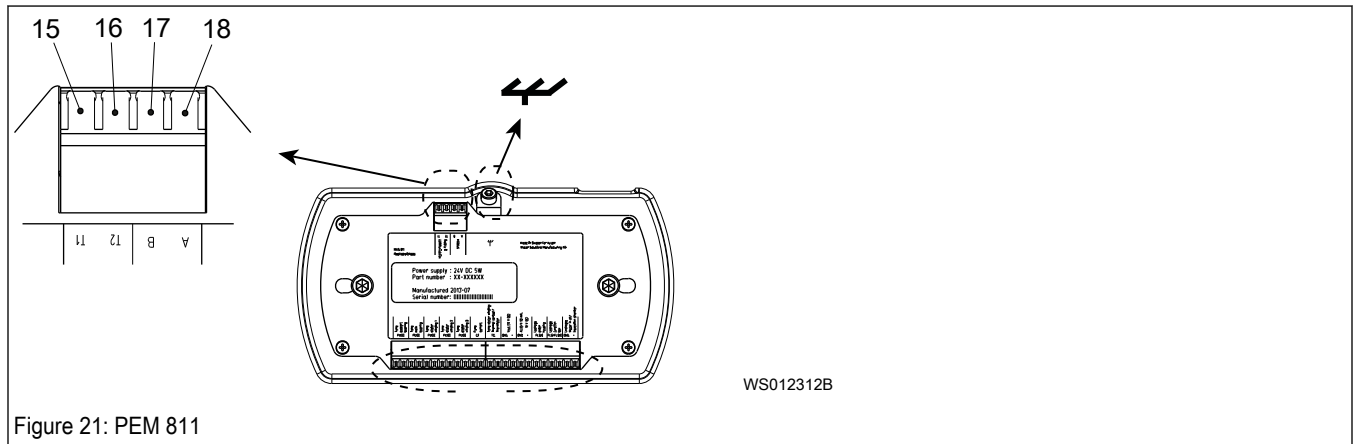

Figure 21: PEM 811

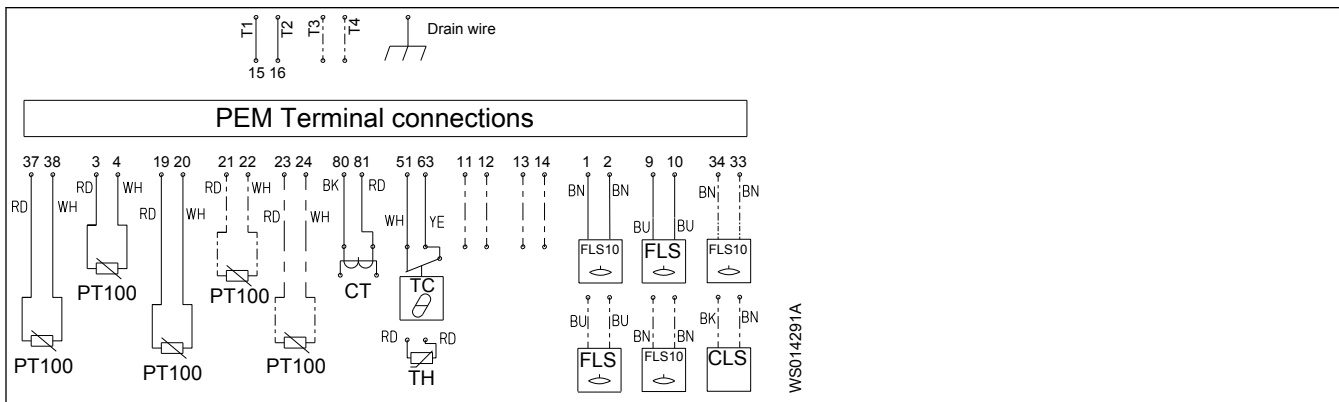

Figure 22: PEM 811 terminal connection overview

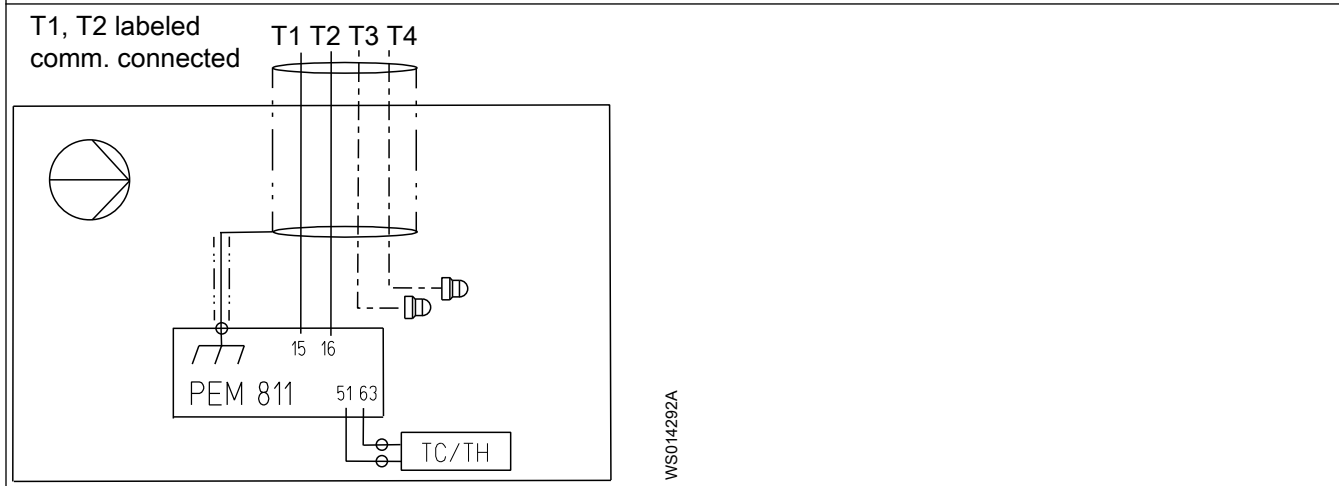

Figure 23: Single cable

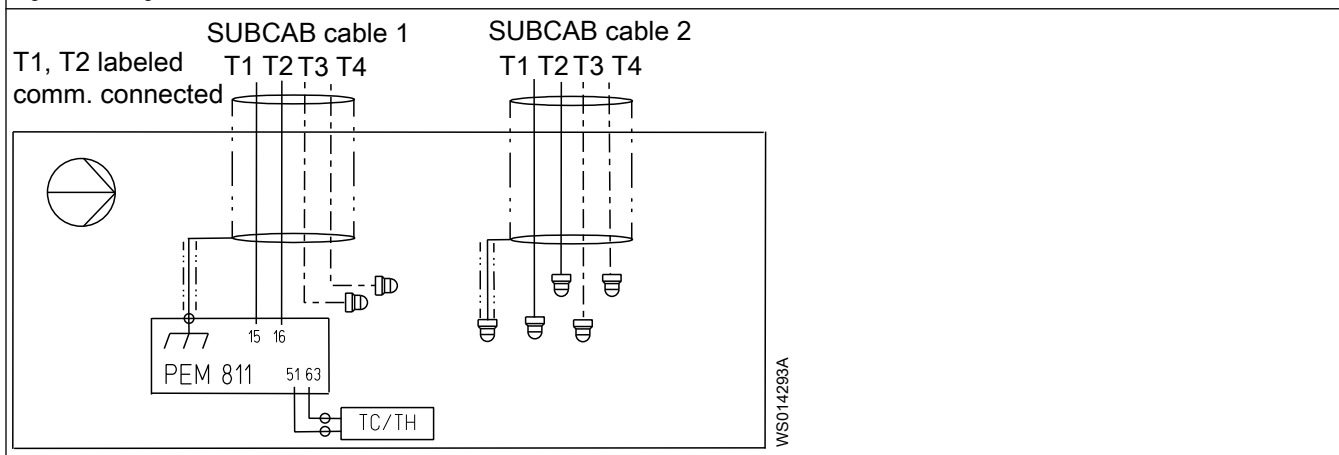

Figure 24: Two cables

Table 4: PEM connections, Ex-proof application

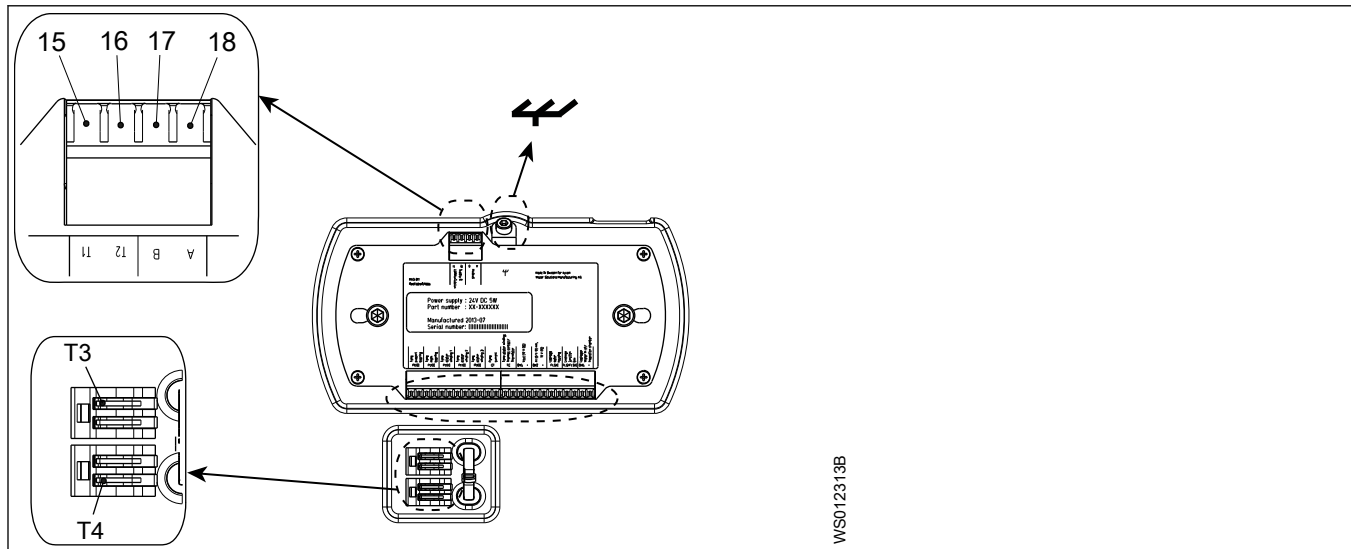

Figure 25: PEM 811

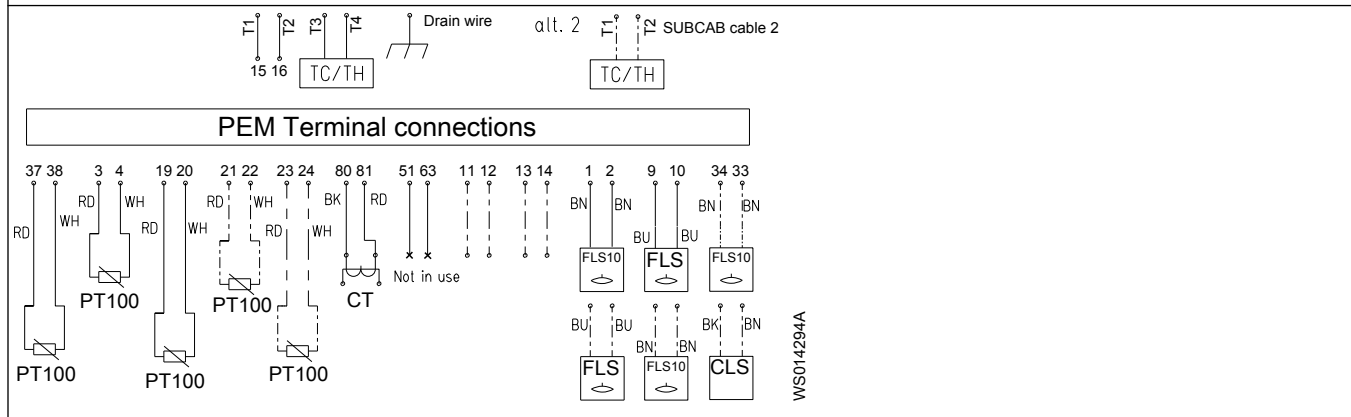

Figure 26: PEM 811 terminal connection overview

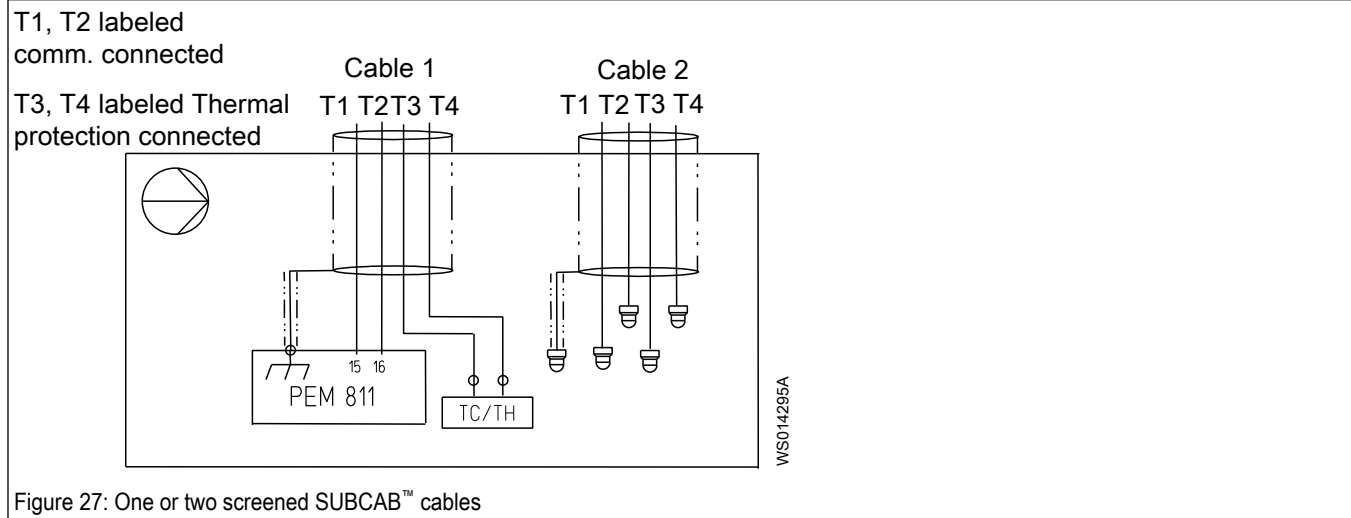
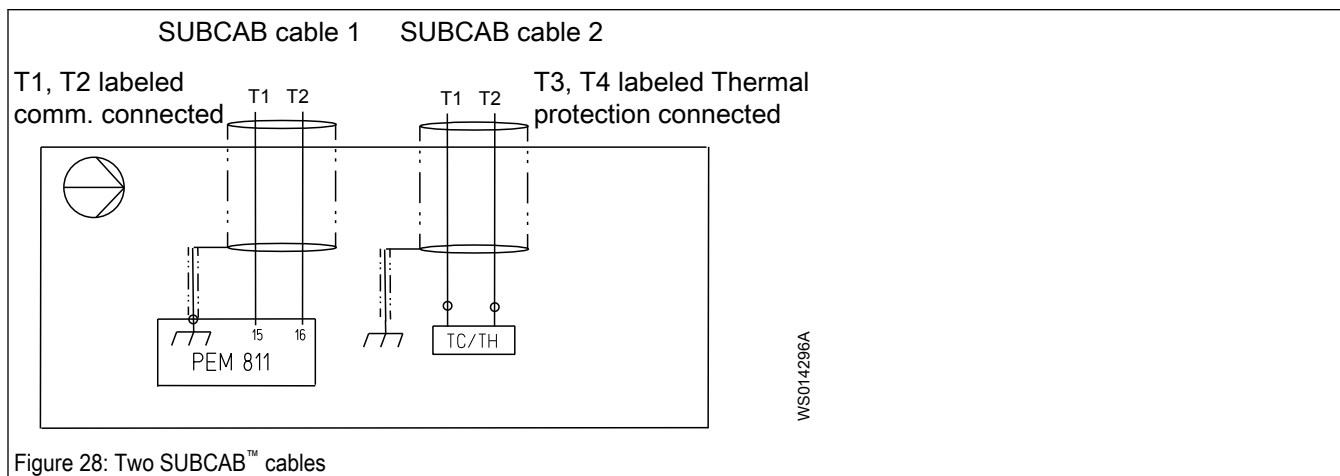

Figure 27: One or two screened SUBCAB™ cables



37, 38	Pt100 temperature sensor Support bearing
3, 4	Pt100 temperature sensor Main bearing
19, 20	Pt100 temperature sensor Stator winding 1
21, 22	Pt100 temperature sensor Stator winding 2
23, 24	Pt100 temperature sensor Stator winding 3
80, 81	CT Pump current
51, 63	Thermal contact or thermistor, TC Stator winding Not used for Ex-pumps
11, 12	$V_{out} +12$ VDC, GND
13, 14	Analog input 0/4–20 mA +12 VDC, GND
1, 2	FLS/FLS10 Leakage, inspection chamber, or stator housing
9, 10	FLS/FLS10 Leakage, junction box
34, 33	FLS10, Leakage, inspection chamber CLS, Water in oil
15	T1 Power supply and communication
16	T2 Power supply and communication
17	B Modbus
18	A Modbus

## 4.11 MAS 711

EN

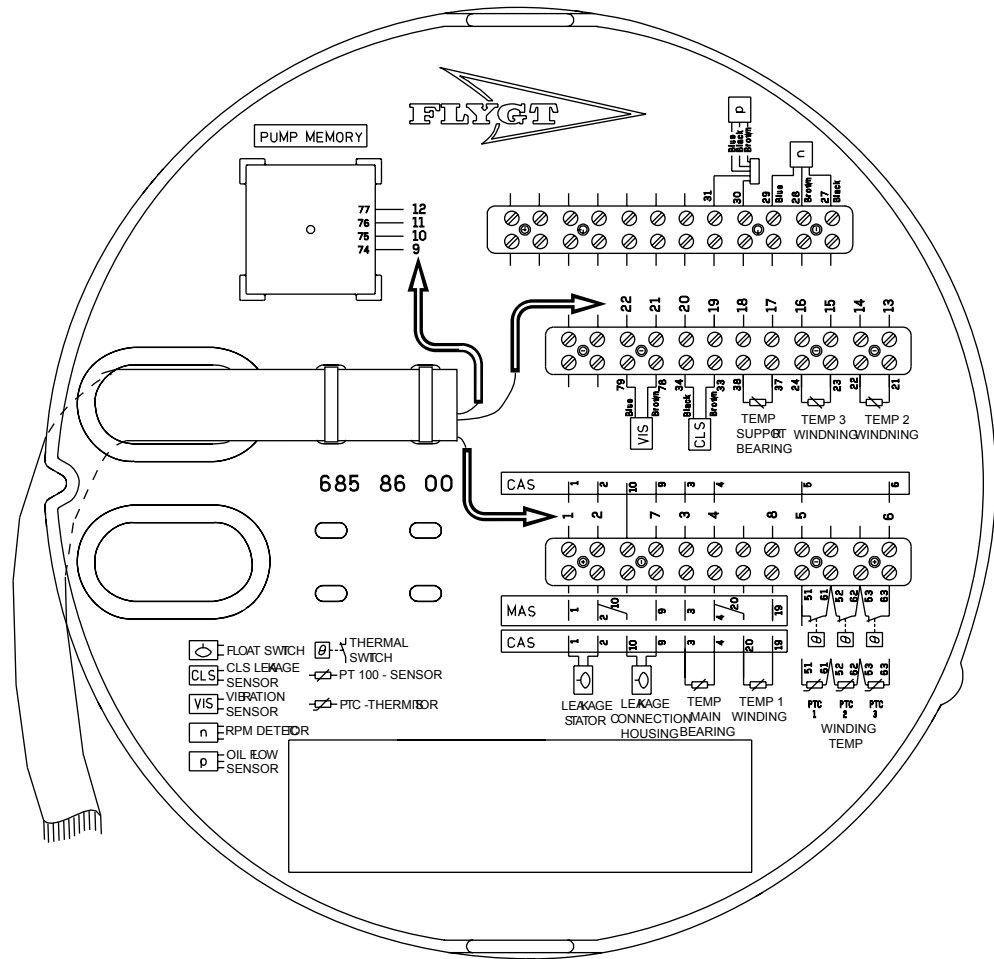

WS000508A

Figure 29: MAS 711, arrows indicate SUBCAB cable lead numbers

## 4.12 T-installation: Bleed air before starting pump

1. Open the valve on the air vent line and bleed out the air. See the following figure.

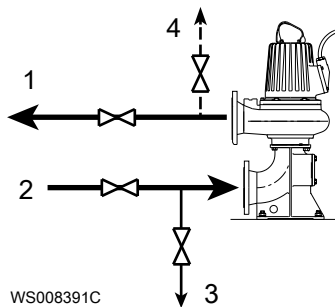

WS008391C

1. Outlet line
2. Inlet line
3. Line to drain
4. Air vent

Figure 30: T-installation

2. Close the valve on the air vent line before the pump is started.

## 4.13 Check the impeller rotation

**CAUTION: Crush Hazard**

The starting jerk can be powerful. Make sure nobody is close to the unit when it is started.

EN

1. Start the motor.
2. Stop the motor after a few seconds.
3. Check that the impeller rotates according to this illustration.

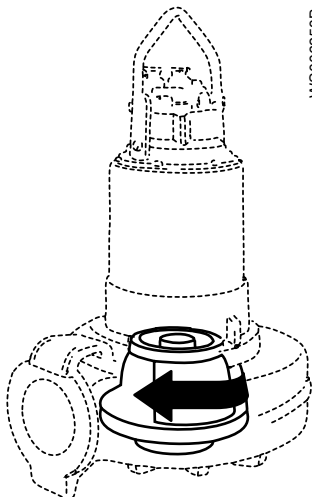

The correct direction of impeller rotation is clockwise when you look at the pump from above.

4. If the impeller rotates in the wrong direction, then transpose two phase leads (3-phase) and do this procedure again.

# 5 Operation

## 5.1 Precautions

Before taking the unit into operation, check the following:

- All recommended safety devices are installed.
- The cable and cable entry have not been damaged.
- All debris and waste material has been removed.

---

### NOTICE:

Never operate the pump with the discharge line blocked, or the discharge valve closed.

---



### WARNING: Crush Hazard

Risk of automatic restart.

---

### Distance to wet areas



### WARNING: Electrical Hazard

Risk of electrical shock or burn. You must connect an additional ground- (earth-) fault protection device to the grounded (earthed) connectors if persons are likely to come into contact with liquids that are also in contact with the pump or pumped liquid.

---



### CAUTION: Electrical Hazard

Risk of electrical shock or burn. The equipment manufacturer has not evaluated this unit for use in swimming pools. If used in connection with swimming pools then special safety regulations apply.

---

### Noise level

### NOTICE:

The sound power level of the product is lower than 70 dB(A). However, in some installations the resulting sound pressure level may exceed 70 dB(A) at certain operating points on the performance curve. Make sure that you understand the noise level requirements in the environment where the product is installed. Failure to do so may result in hearing loss or violation of local laws.

---

## 5.2 Estimate zinc anode replacement intervals

The mass and surface area of the zinc anodes are designed to protect the pump surface for 1 year in sea water with an average temperature of 20°C (68°F). Shorter inspection intervals and anode replacement can be required, depending upon the water temperature and the chemical composition as well as the presence of other metals in the vicinity of the pump.

The rate of zinc consumption, and the appropriate inspection intervals, can be estimated by measuring how much zinc is consumed during the first two months following installation.

Anodes are replaced when the anode mass is reduced to a selected fraction of its initial mass. The recommended interval for the selection fraction is 0.25–0.50 (25–50%).

1. Remove, weigh, and reinstall one or more of the exterior zinc anodes before starting up the pump.
2. After two months, remove and weigh the same zinc anode or anodes again.
3. Divide the lapsed time in days (between steps 1 and 2) by the anode weight loss in grams to get the calculated anode consumption rate (days/gram).

If multiple anodes were weighed, then use the anode which has lost the most weight for this calculation.

4. Calculate future replacement intervals so that they occur when the selected fraction of zinc is remaining.

## 5.3 Start the pump

EN



---

**CAUTION: Crush Hazard**

The starting jerk can be powerful. Make sure nobody is close to the unit when it is started.

---



---

**CAUTION: Thermal Hazard**

The surfaces or parts of the unit may become hot during operation. Allow surfaces to cool before starting work, or wear heat-protective clothing.

---

**NOTICE:**

Make sure that the rotation of the impeller is correct. For more information, see Check the impeller rotation.

---

1. Remove the fuses or open the circuit breaker, and check that the impeller can rotate freely.



---

**WARNING: Crush Hazard**

Never put your hand into the pump housing.

---

2. Start the pump.

# 6 Maintenance

## 6.1 Precautions



Before starting work, make sure that the safety instructions have been read and understood.

---

### **DANGER: Crush Hazard**

Moving parts can entangle or crush. Always disconnect and lock out power before servicing to prevent unexpected startup. Failure to do so could result in death or serious injury.



---

### **DANGER: Inhalation Hazard**

Before entering the work area, make sure that the atmosphere contains sufficient oxygen and no toxic gases.



---

### **WARNING: Biological Hazard**

Infection risk. Rinse the unit thoroughly with clean water before working on it.



---

### **CAUTION: Crush Hazard**

Make sure that the unit cannot roll or fall over and injure people or damage property.

Make sure that you follow these requirements:

- Check the explosion risk before you weld or use electrical hand tools.
- Allow all system and pump components to cool before you handle them.
- Make sure that the product and its components have been thoroughly cleaned.
- Before starting work, make sure that the work area is well-ventilated.
- Do not open any vent or drain valves or remove any plugs while the system is pressurized. Make sure that the pump is isolated from the system and that pressure is relieved before you disassemble the pump, remove plugs, or disconnect piping.

### **Ground continuity verification**

A ground (earth) continuity test must always be performed after service.

## 6.2 Maintenance guidelines

During the maintenance and before reassembly, always remember to perform these tasks:

- Clean all parts thoroughly, particularly O-ring grooves.
- Change all O-rings, gaskets, and seal washers.
- Lubricate all springs, screws, O-rings with grease.

During the reassembly, always make sure that existing index markings are in line.

The reassembled drive unit must always be insulation-tested and the reassembled pump must always be test-run before normal operation.

## 6.3 Torque values

All screws and nuts must be lubricated to achieve correct tightening torque. Screws that are screwed into stainless steel must have the threads coated with applicable lubricants to prevent seizing.

If there is a question regarding the tightening torques, then contact a sales or authorized service representative.

EN

### Screws and nuts

Table 5: Stainless steel, A2 and A4, torque Nm (lbf-ft)

Property class	M4	M5	M6	M8	M10	M12	M16	M20	M24	M30
50	1.0 (0.74)	2.0 (1.5)	3.0 (2.2)	8.0 (5.9)	15 (11)	27 (20)	65 (48)	127 (93.7)	220 (162)	434 (320)
70, 80	2.7 (2)	5.4 (4)	9.0 (6.6)	22 (16)	44 (32)	76 (56)	187 (138)	364 (268)	629 (464)	1240 (915)
100	4.1 (3)	8.1 (6)	14 (10)	34 (25)	66 (49)	115 (84.8)	248 (183)	481 (355)	—	—

Table 6: Steel, torque Nm (lbf-ft)

Property class	M4	M5	M6	M8	M10	M12	M16	M20	M24	M30
8.8	2.9 (2.1)	5.7 (4.2)	9.8 (7.2)	24 (18)	47 (35)	81 (60)	194 (143)	385 (285)	665 (490)	1310 (966.2)
10.9	4.0 (2.9)	8.1 (6)	14 (10)	33 (24)	65 (48)	114 (84)	277 (204)	541 (399)	935 (689)	1840 (1357)
12.9	4.9 (3.6)	9.7 (7.2)	17 (13)	40 (30)	79 (58)	136 (100)	333 (245)	649 (480)	1120 (825.1)	2210 (1630)

Table 7: Brass, torque Nm (lbf-ft)

M5	M8	M10
2.7 (2.0)	11 (8.1)	22 (16.2)

### Hexagon screws with countersunk heads

For hexagon socket head screws with countersunk head, maximum torque for all property classes must be 80% of the values for property class 8.8.

### Round nuts with set screws

Table 8: Set screw, torque Nm (lbf-ft)

The torque values are only valid for the set screw, and not for the round nut.

M8	M10
18 (13)	35 (26)

## 6.4 Change the coolant

This image shows the plugs that are used to change the coolant.

EN

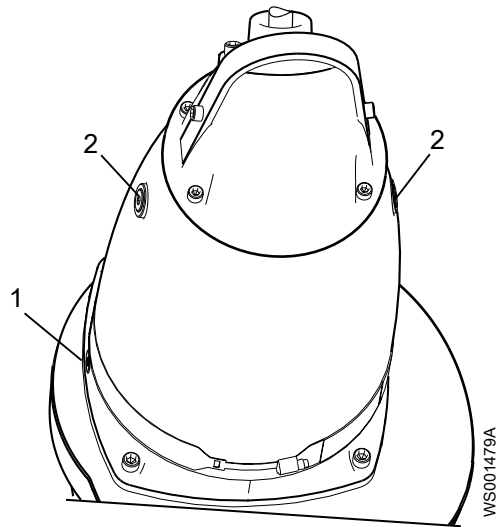

Figure 31: With a cooling jacket

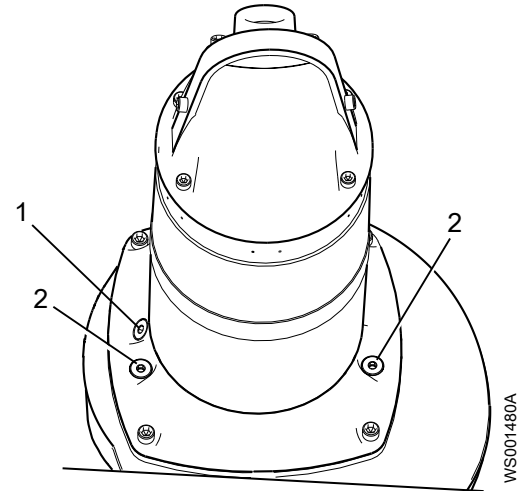

Figure 32: Without a cooling jacket

- 1. Inspection plug
- 2. Coolant plugs

### 6.4.1 Empty the coolant



**CAUTION: Compressed Gas Hazard**

Air inside the chamber may cause parts or liquid to be propelled with force. Be careful when opening. Allow the chamber to de-pressurize before removal of the plug.

1. Empty the coolant in the inspection chamber:
  - a) Remove the inspection plug.

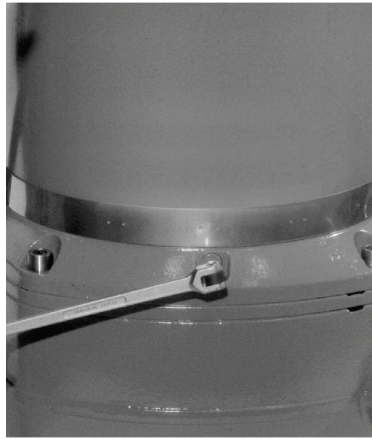

Figure 33: With a cooling jacket

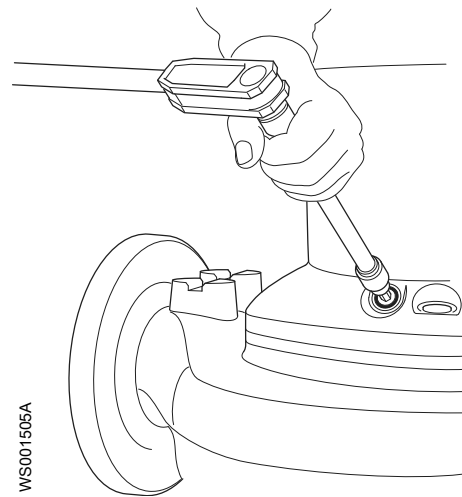

Figure 34: Without a cooling jacket

- b) Pump out any coolant from the inspection chamber, as shown here.

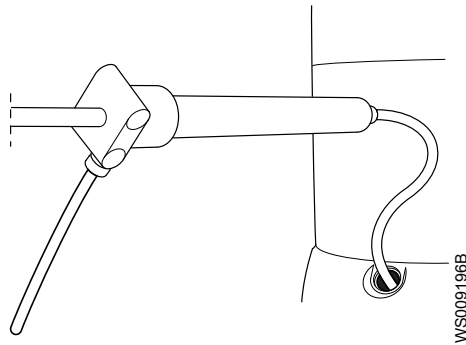

Figure 35: With a cooling jacket

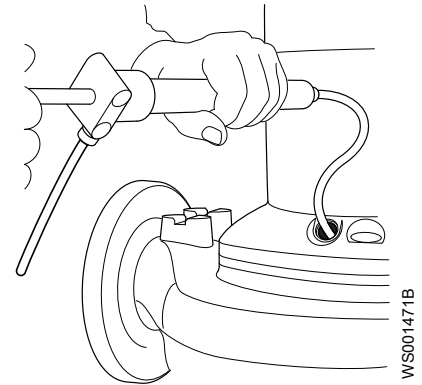

Figure 36: Without a cooling jacket

- c) Fit a new O-ring and reinstall the inspection plug. Tighten the plug.  
Tightening torque: 44 Nm (33 lbf-ft)
2. To empty the coolant with the pump upright, do the following:  
This method is applicable only for pumps without cooling jackets.
  - a) Remove the coolant plugs.

**CAUTION: Compressed Gas Hazard**

Air inside the chamber may cause parts or liquid to be propelled with force. Be careful when opening. Allow the chamber to de-pressurize before removal of the plug.

- b) Use a pump to remove the coolant.

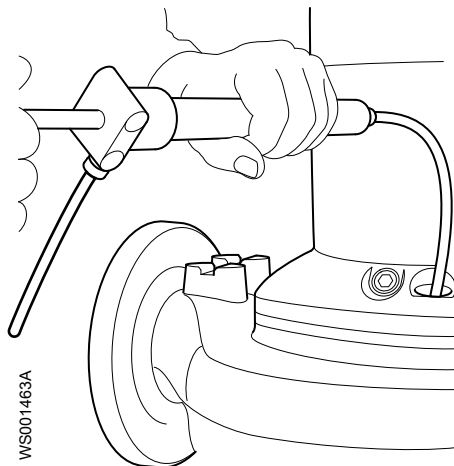

3. If it is necessary to separate the drive unit from the hydraulic unit, then do the following:
  - a) Carefully open the coolant plugs to release any built-up pressure inside the cooling jacket.

**CAUTION: Compressed Gas Hazard**

Air inside the chamber may cause parts or liquid to be propelled with force. Be careful when opening. Allow the chamber to de-pressurize before removal of the plug.

- b) After releasing any built-up pressure in the cooling jacket, reinstall the coolant plugs.
- c) Remove the pump housing screws.
- d) Remove the drive unit from the pump housing.

EN

**NOTICE:**

Do not allow the weight of the pump to rest on any portion of the impeller. The impeller must not be allowed to make contact with the concrete floor or other hard or rough surfaces.

4. To empty the coolant by using the pump in a horizontal position, do the following:
  - a) Put the pump horizontally, so that one of the coolant plugs is at the lowest point of the pump.  
It is important that the coolant drains completely.
  - b) Put a container under the pump.
  - c) Remove the coolant plugs and empty the coolant.

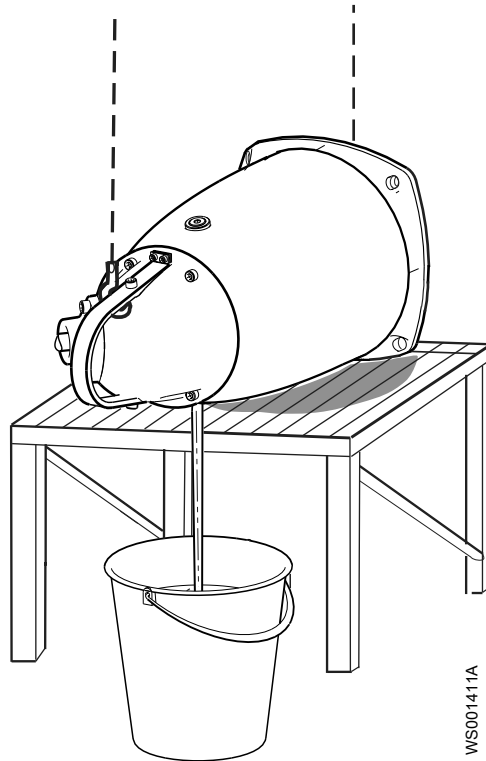

Figure 37: With a cooling jacket

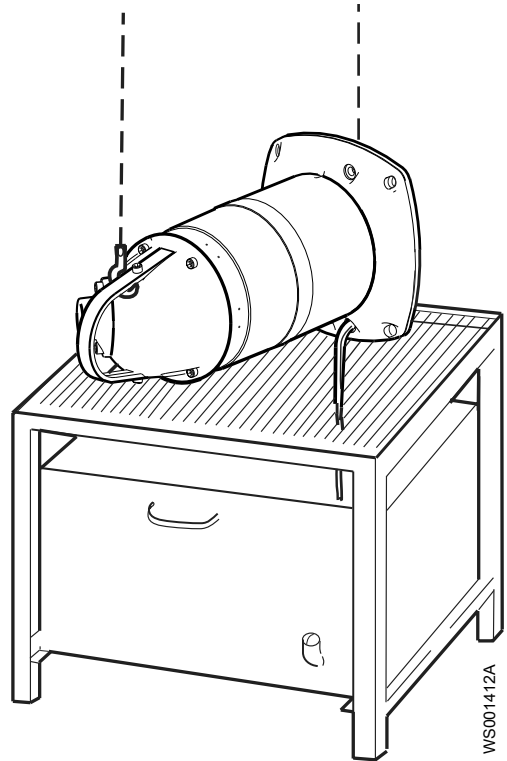

Figure 38: Without a cooling jacket

**6.4.2 Fill with coolant**

Use a coolant that is a mixture of 70% deionized or distilled water, and 30% DOWCAL 200E monopropylene glycol. If DOWCAL 200E from Dow Chemical Company is not available, then contact your local Xylem representative. The monopropylene glycol must fulfill the Xylem material standard M0800.82.0002.

**NOTICE:**

Deionized or distilled water must be used in the water-glycol mixture.

If the pumped liquid includes potable water or substances to be ingested, then contact a sales or authorized service representative.

1. Fill with coolant until it overflows through the opposite hole, as shown here.

Pump	Quantity, L (qt.)	
	With cooling jacket	Without cooling jacket
3315	55 (58.1)	9.5 (10.0)

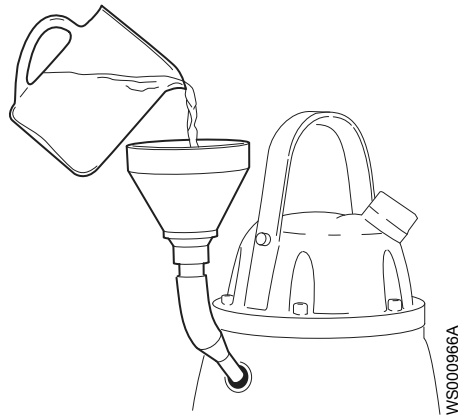

Figure 39: With cooling jacket



Figure 40: Without cooling jacket

2. Fit new O-rings and reinstall the coolant plugs. Tighten the plugs.  
Tightening torque: 44 Nm (33 lbf·ft)

## 6.5 Service the pump

Type of maintenance	Purpose	Inspection interval
Initial inspection	A Xylem-authorized personnel checks the pump condition. From the results, the personnel recommends the intervals for the periodical inspection and overhaul for the installation.	Within the first year of operation.
Periodical inspection	The inspection prevents operational interruptions and machine breakdowns. The measures to increase performance and pump efficiency are decided for each application. They can include such things as impeller trimming, wear part control and replacement, control of zinc-anodes and control of the stator.	Up to 12,000 hours or three years, whichever comes first. Applies to normal applications and operating conditions at media (liquid) temperatures <40°C (104°F).
Overhaul	The overhaul lengthens the operating lifetime of the product. It includes the replacement of key components and the measures that are taken during an inspection.	Up to 24,000 hours or six years, whichever comes first. Applies to normal applications and operating conditions at media (liquid) temperatures <40°C (104°F).

### NOTICE:

Shorter intervals may be required when the operating conditions are extreme, for example with very abrasive or corrosive applications or when the liquid temperatures exceed 40°C (104°F).

### 6.5.1 Inspection

Service item	Action
Cable	<ol style="list-style-type: none"> <li>1. If the outer jacket is damaged, then replace the cable.</li> <li>2. Check that the cables do not have any sharp bends and are not pinched.</li> </ol>
Connection to power	Check that the connections are properly secured.
Electrical cabinets	Check that they are clean and dry.

Service item	Action
Impeller	<ol style="list-style-type: none"> <li>1. Check the impeller clearance.</li> <li>2. Adjust the impeller, if necessary.</li> </ol>
Inspection chamber	<ol style="list-style-type: none"> <li>1. Drain all liquid, if any.</li> <li>2. Check the resistance of the leakage sensor. Normal value approximately 1200 ohms, alarm approximately 430 ohms.</li> <li>3. Check the resistance of the leakage sensor. If the pump is connected to the MAS 801 or MAS 711, then it is recommended that the sensors be checked in the MAS unit. Otherwise, use a multimeter. For values, see <a href="#">Connection to the pump</a>. Make sure to select values for the appropriate monitoring equipment and sensor combination.</li> </ol>
Insulation	<p>Use a megger maximum 1000 V.</p> <ol style="list-style-type: none"> <li>1. Check that the resistance between the ground (earth) and phase lead is more than 5 megohms.</li> <li>2. Conduct a phase-to-phase resistance check.</li> </ol>
Junction box	<ol style="list-style-type: none"> <li>1. Check that it is clean and dry.</li> <li>2. Check the resistance of the leakage sensor. If the pump is connected to the MAS 801 or MAS 711, then it is recommended that the sensors be checked in the MAS unit. Otherwise, use a multimeter. Normal value approximately 1530 ohms, alarm approximately 330 ohms.</li> </ol>
Level regulators	Check the condition and functionality.
Lifting device	Check that the local safety regulations are followed.
Lifting handle	<ol style="list-style-type: none"> <li>1. Check the screws.</li> <li>2. Check the condition of the lifting handle and the chain.</li> <li>3. If necessary, replace.</li> </ol>
O-rings	<ol style="list-style-type: none"> <li>1. Replace the oil plug O-rings.</li> <li>2. Replace the O-rings at the entrance or junction cover.</li> <li>3. Grease the new O-rings.</li> </ol>
Overload protection and other protections	Check the correct settings.
Personnel safety devices	Check the guard rails, covers, and other protections.
Rotation direction	Check the impeller rotation.
Seal housing	<ol style="list-style-type: none"> <li>1. Fill with new coolant, if necessary. Applicable for Ex-version.</li> <li>2. Check that the freezing point is lower than -13°C (9°F).</li> </ol>
Terminal board	Check that the connections are properly secured.
Temperature sensors: – Thermal contact – Thermistor – Pt100	<p>If the pump is connected to the MAS 801 or MAS 711, then it is recommended that the sensors be checked in the MAS unit. Otherwise, use a multimeter. Do not use a device applying a higher voltage than 2.5 V.</p> <ol style="list-style-type: none"> <li>1. Disconnect the sensor leads.</li> <li>2. Measure the resistance to check the status of the sensor and leads according to values in <a href="#">Make the electrical connections</a> on page 32. Make sure to select values for the appropriate sensor, monitoring equipment, and sensor combination.</li> <li>3. Measure between each sensor lead to ground (earth) to establish that the resistance is infinite (or at least several Megaohm).</li> </ol>
Voltage and amperage	Check the running values.

## 6.5.2 Overhaul

The basic repair kit includes O-rings, seals, and bearings.

For an overhaul, do the following in addition to the tasks listed under Inspection.

Service item	Action
Support and main bearing	Replace the bearings with new bearings.
Mechanical seal	Replace with new seal units.

EN

## 6.5.3 Service in case of alarm

For information about indication values for sensors, see [Make the electrical connections](#) on page 32.

Alarm source	Action
FLS	<ol style="list-style-type: none"> <li>1. Check for liquid in the connection housing.</li> <li>2. Drain all liquid, if any.</li> <li>3. Check the O-rings and the cable entry, if liquid was found.</li> </ol>
FLS10	<ol style="list-style-type: none"> <li>1. Drain the fluid in the inspection chamber.</li> <li>2. Check the coolant level. Fill with new coolant if necessary.</li> <li>3. Check the freezing point (lower than -13°C or 9°F).</li> </ol> <p>Check the inspection chamber again after one week of operation. If leakage has occurred, then do the following:</p> <ol style="list-style-type: none"> <li>1. Drain the fluid.</li> <li>2. Change the mechanical seal unit.</li> <li>3. Replace with new coolant.</li> </ol>
The thermistor/Thermal contact	<ol style="list-style-type: none"> <li>1. Check the coolant level (pump with cooling jacket).</li> <li>2. Check the start and stop levels.</li> </ol>
The overload protection	Check that the impeller can rotate freely.

## 6.6 Replace the impeller

Required tools:

- 14 mm hexagon bit adapter with an extension of at least a 100 mm (4 in)
- Trim tool (24 mm hexagon bar, 300 mm long)
- Rod (wood or plastic) for locking the impeller in place



### CAUTION: Cutting Hazard

Worn parts can have sharp edges. Wear protective clothing.

### NOTICE:

When laying the pump on its side, do not allow the weight of the pump to rest on any portion of the impeller. The impeller must not be allowed to make contact with the concrete floor or other hard and rough surfaces.

### NOTICE:

If you fail with the impeller installation, you must redo the installation procedure from the beginning.

## 6.6.1 Replace the impeller for wet installation

## 6.6.1.1 Remove the impeller: wet installation

**CAUTION: Cutting Hazard**

Sharp edges. Wear protective clothing.

1. Place the pump in a horizontal position.
2. Loosen the impeller:
  - a) Lock the impeller in place by inserting a rod through the pump housing outlet.
  - b) Remove the cover screw and the cover.
  - c) Remove the screw unit.

For instructions about how to remove the screw unit, see [Handle the screw unit](#) on page 76.

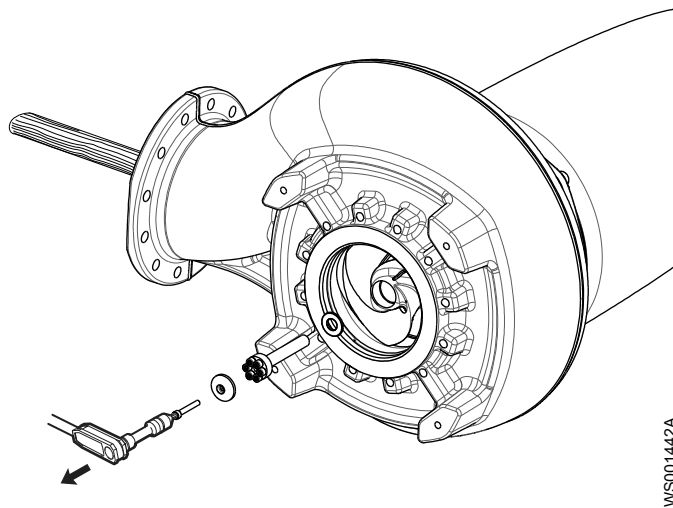

WS001442A

- d) Turn the adjustment screw counterclockwise until the impeller breaks free from the shaft.  
Use the trim tool.

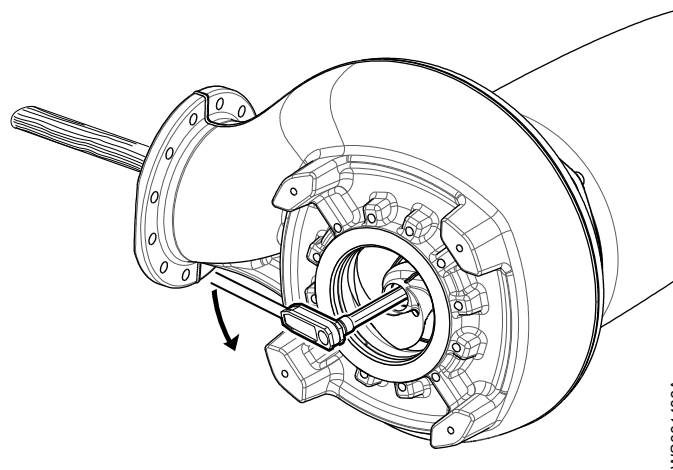

WS001436A

- e) Hand-tighten the center screw to prevent the impeller from falling off.
- f) Remove the rod.
3. Raise the pump.
4. Remove the drive unit from the pump housing:
  - a) Remove the pump housing screws.

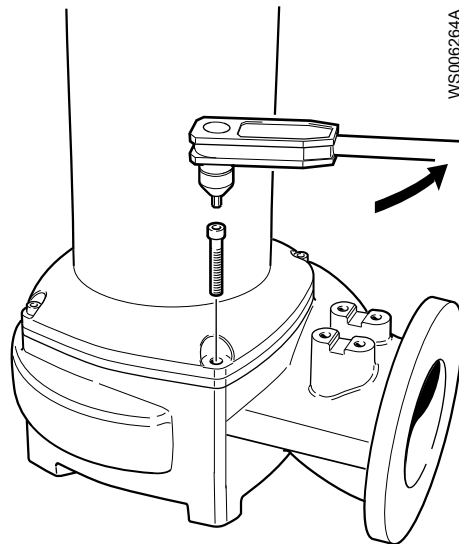

b) Remove the drive unit from the pump housing.

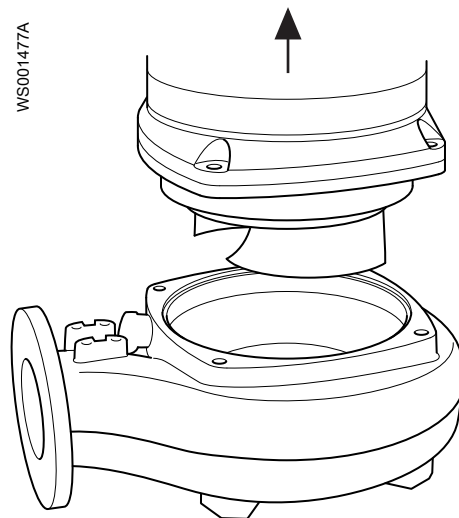

5. Remove the impeller:

a) Fit M12 lifting eyebolts into two of the holes for the pump housing screws and place the drive unit in a horizontal position.



WS002109A

b) Prevent the impeller from falling off by attaching a round sling. Protect the round sling from the trailing edges of the impeller.



WS002110A

- c) Remove the screw unit.  
For instructions about how to remove the screw unit, see [Handle the screw unit](#) on page 76.
- d) Remove the impeller and the conical sleeve.

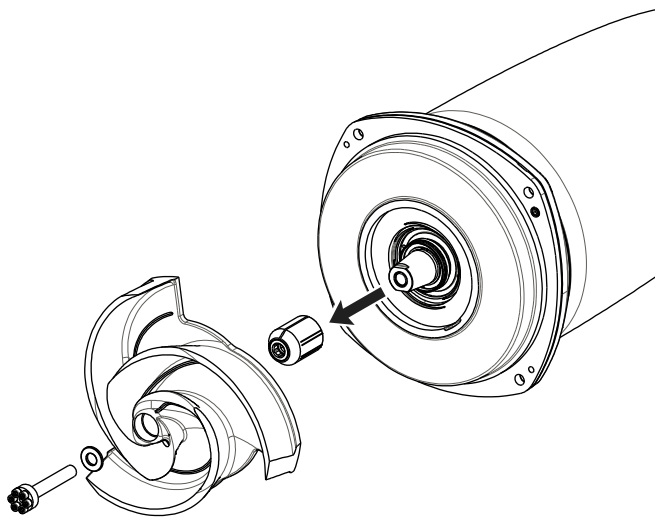

WS001444A

### 6.6.1.2 Install the impeller: wet installation

1. Prepare the shaft:
  - a) Polish off any flaws by using a fine emery cloth.  
The end of the shaft must be clean and free from burrs.
  - b) Coat the inner conical, the outer cylindrical surfaces, and the thread of the conical sleeve with a thin layer of grease.  
The correct lubrication is grease for bearings, for example Exxon Mobil Unirex N3, Mobil Mobilith SHC 220 or equivalent.

**NOTICE:**

Surplus grease can cause the impeller to become loose. Remove surplus grease from conical and/or cylindrical surfaces of shafts and/or sleeves.

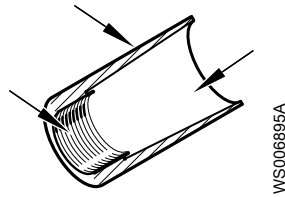

WS006895A

## 2. Mount the impeller:

- a) Adjust the adjustment screw so that it is flush with the sleeve.  
Use the trim tool.

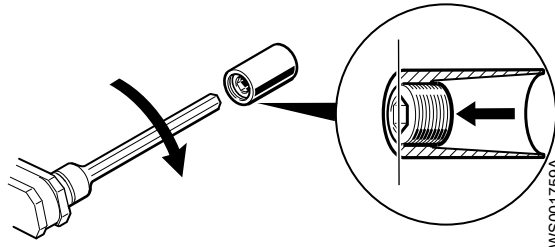

WS001759A

- b) Lift the impeller by attaching a round sling.  
Protect the round sling from the trailing edges of the impeller.



WS002110A

- c) Fit the sleeve into the impeller hub.
- d) Carefully fit the impeller to the shaft.  
To prevent the sleeve and impeller from getting stuck part way on, make sure that they are pushed straight onto the shaft.
- e) Prepare the screw unit. Hand-tighten the center screw to prevent it from falling off.  
For instructions about how to fit the screw unit, see [Handle the screw unit](#) on page 76.

If the screw unit is not easily screwed back into the shaft, then replace the screw unit.

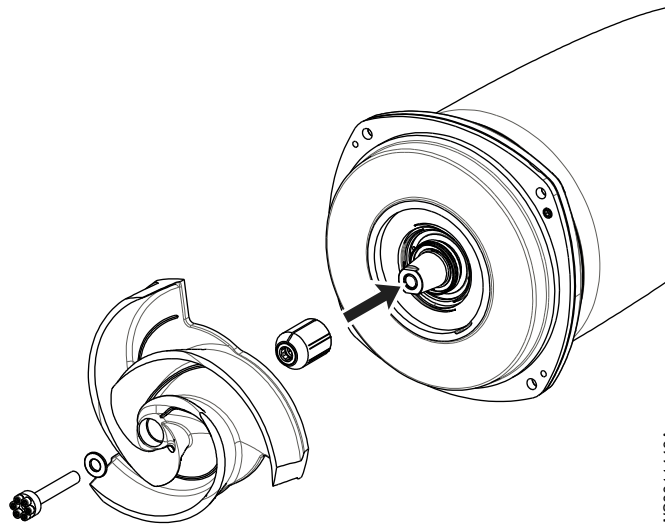

3. Fit the pump housing:

- a) Fit a new and lubricated O-ring on the seal housing cover.
- b) Lubricate the pump housing screws.
- c) Raise the drive unit.
- d) Place the drive unit into the pump housing.
- e) Adjust its position so that the inspection hole is on the same side as the flush valve.
- f) Tighten the pump housing screws in diagonal sequence.

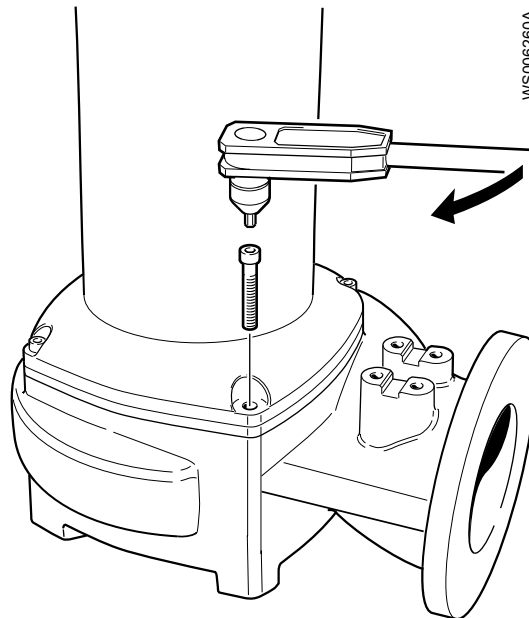

4. Remove the screw unit.

- a) Place the pump horizontally.
- b) Lock the impeller in place by inserting a rod through the pump housing outlet.
- c) Remove the screw unit.

5. Adjust the impeller:

- a) Using the trim tool, turn the adjustment screw clockwise until the impeller makes contact with the pump housing.

If the adjustment screw is turned the wrong way, then the impeller will not be possible to remove the next time.

- b) If possible, tighten it a further 1/8 turn (45°).

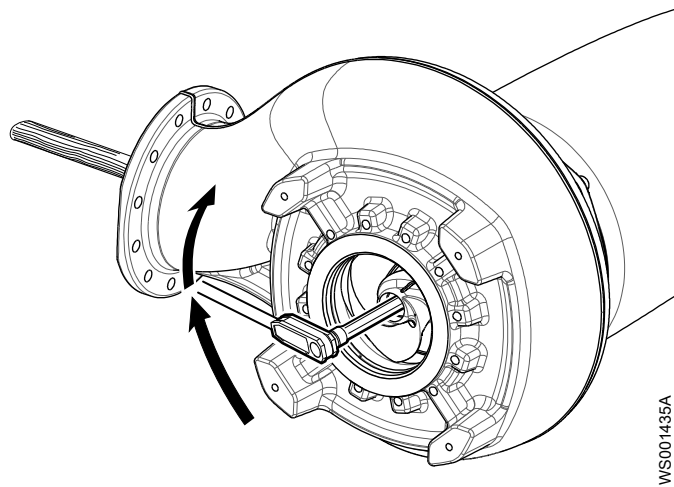

6. Fasten the impeller:

- a) Fit the screw unit.

For instructions about how to fit the screw unit, see [Handle the screw unit](#) on page 76.

- b) Remove the rod that is used to lock the impeller.  
c) Check that the impeller can rotate freely.

## 6.6.2 Replace the impeller for dry installation

### 6.6.2.1 Remove the impeller: dry installation



**CAUTION: Cutting Hazard**

Sharp edges. Wear protective clothing.

1. Remove the drive unit from the pump housing:

- a) Remove the pump housing screws.

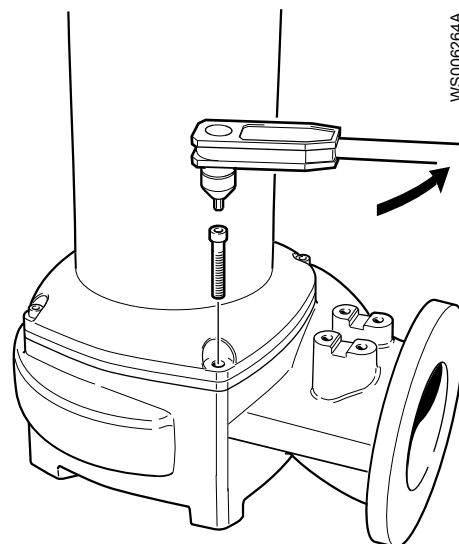

- b) Remove the drive unit from the pump housing.

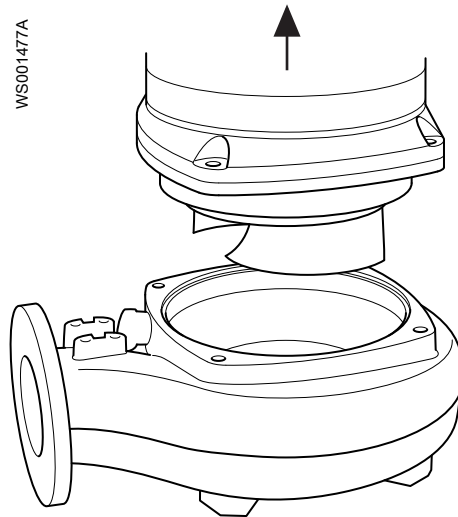

2. Remove the impeller:

- a) Fit M12 lifting eyebolts into two of the holes for the pump housing screws and place the drive unit in a horizontal position.

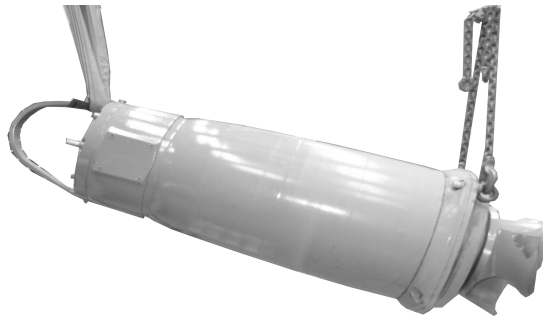

WS002109A

- b) Lock the impeller as shown in the figure.



WS002111A

- c) Remove the cover screw and the cover.  
 d) Remove the screw unit.  
 For instructions about how to remove the screw unit, see [Handle the screw unit](#) on page 76.  
 e) Remove the board that locks the impeller.  
 f) Prevent the impeller from falling off by attaching a round sling.  
 Protect the round sling from the trailing edges of the impeller.



WS002110A

- g) Turn the adjustment screw counterclockwise until the impeller breaks free from the shaft.  
Use the trim tool.
- h) Remove the impeller and the conical sleeve.

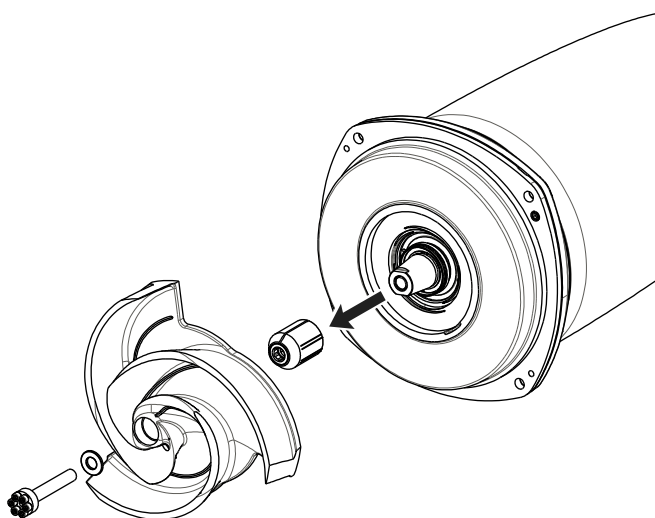

WS001444A

### 6.6.2.2 Install the impeller: dry installation

1. Prepare the shaft:
  - a) Polish off any flaws by using a fine emery cloth.  
The end of the shaft must be clean and free from burrs.
  - b) Coat the inner conical, the outer cylindrical surfaces, and the thread of the conical sleeve with a thin layer of grease.  
The correct lubrication is grease for bearings, for example Exxon Mobil Unirex N3, Mobil Mobilith SHC 220 or equivalent.

**NOTICE:**

Surplus grease can cause the impeller to become loose. Remove surplus grease from conical and/or cylindrical surfaces of shafts and/or sleeves.

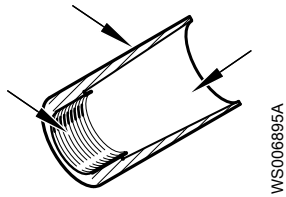

## 2. Mount the impeller:

- a) Unscrew the adjustment screw approximately 5 mm (0.2 in).



- b) Measure and note the distance A.

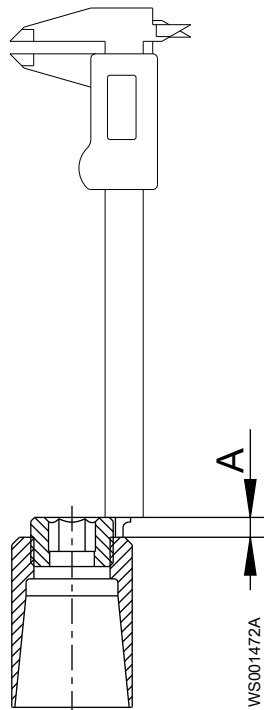

- c) Lift the impeller by attaching a round sling.  
Protect the round sling from the trailing edges of the impeller.



WS002110A

- d) Fit the sleeve into the impeller hub.
- e) Carefully fit the impeller to the shaft.  
To prevent the sleeve and impeller from getting stuck part way on, make sure that they are pushed straight onto the shaft.
- f) Prepare the screw unit. Hand-tighten the center screw to prevent it from falling off.  
For instructions about how to fit the screw unit, see [Handle the screw unit](#) on page 76.  
If the screw unit is not easily screwed back into the shaft, then replace the screw unit.

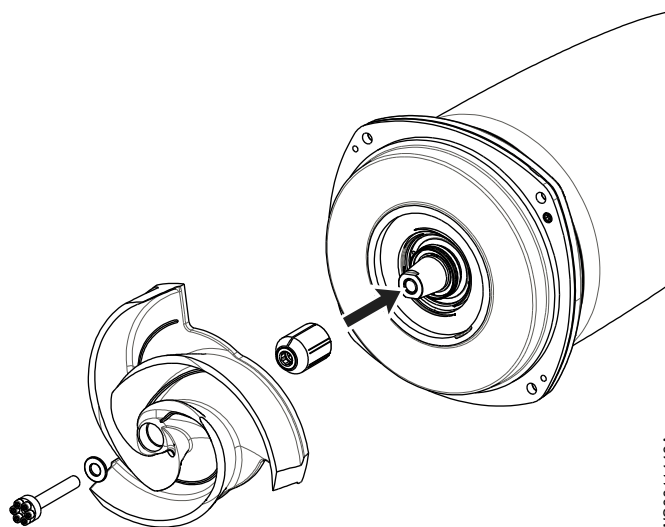

WS0011443A

- g) Tighten the impeller screw.  
Lock the impeller as shown in the figure.



WS002111A

3. Make sure that the O-ring is removed from the seal housing cover.

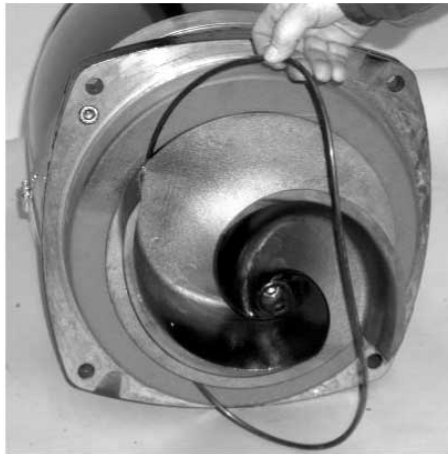

WS002008A

4. Measure the trim distance:

- a) Place the drive unit in the pump housing.

Make sure that the drive unit is parallel with the pump housing by hand-tightening the pump housing screws.

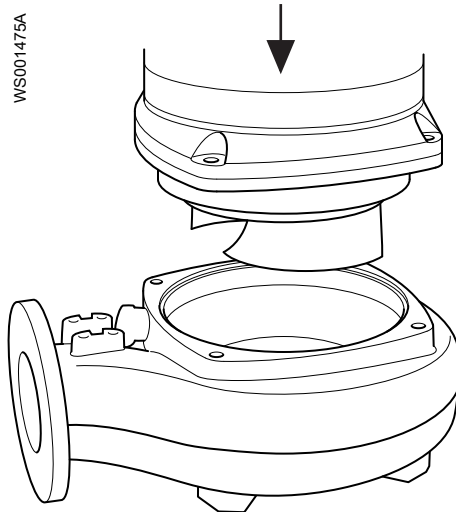

WS001475A

- b) Check the distance between the seal housing cover and the pump housing with a feeler gauge.

Check diagonally at four points.



c) Note the largest distance B.

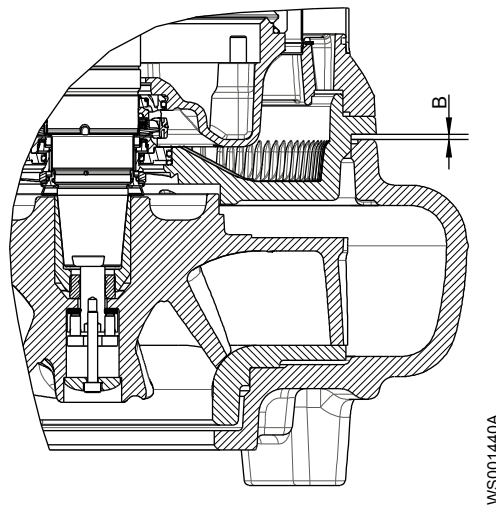

d) Lift the drive unit out of the pump housing and remove the impeller and conical sleeve.

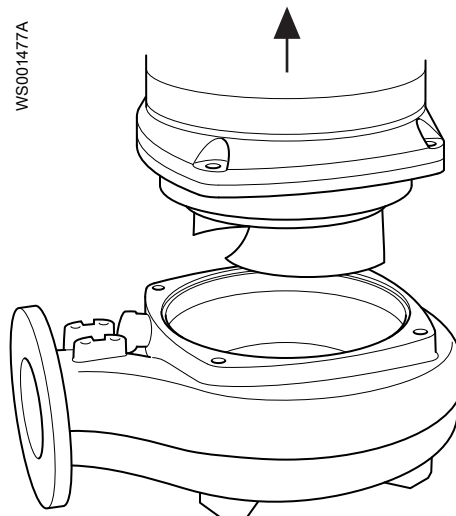

5. Trim to the correct distance:

a) Calculate the measure C according to the formula shown in the image.

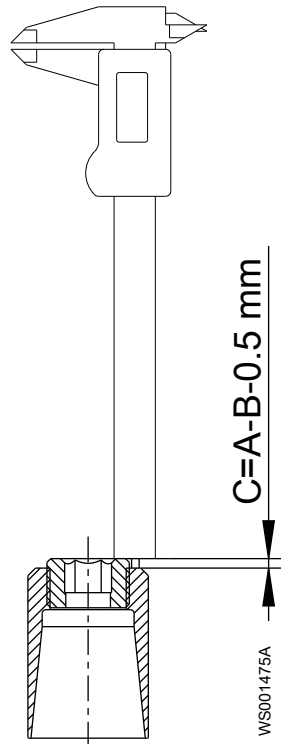

- b) Turn the adjustment screw until C is reached.
6. Fasten the impeller:
- a) Fit the sleeve into the impeller hub.
  - b) Carefully fit the impeller to the shaft.  
To prevent the sleeve and impeller from getting stuck part way on, make sure that they are pushed straight onto the shaft.
  - c) Fit the screw unit.  
For instructions about how to fit the screw unit, see [Handle the screw unit](#) on page 76.
  - d) Tighten the impeller screw.  
Lock the impeller as shown in the figure.



7. Install the drive unit in the pump housing:
  - a) Fit a new and lubricated O-ring to the seal housing cover.

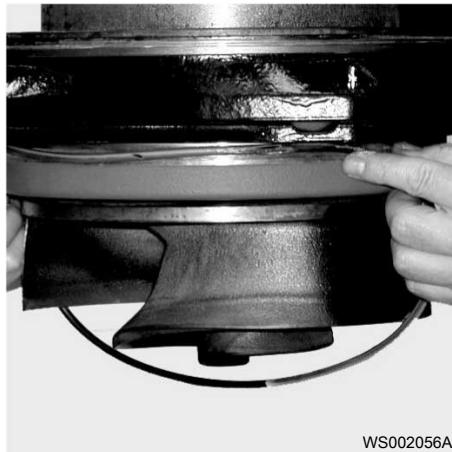

- b) Place the drive unit in the pump housing.  
Make sure that the drive unit is parallel with the pump housing by hand-tightening the pump housing screws.

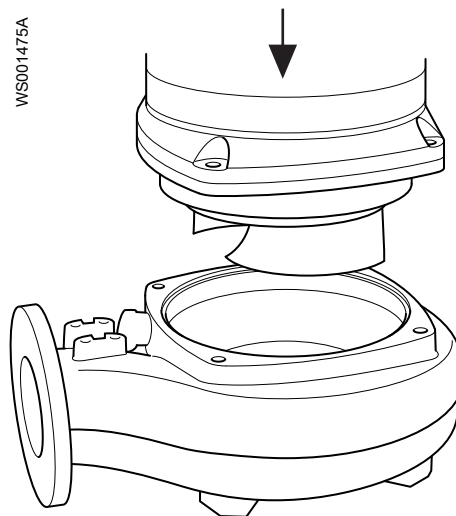

- c) Adjust the position of the drive unit so that the inspection hole is on the same side as the flush valve.  
Tighten the screws diagonally.

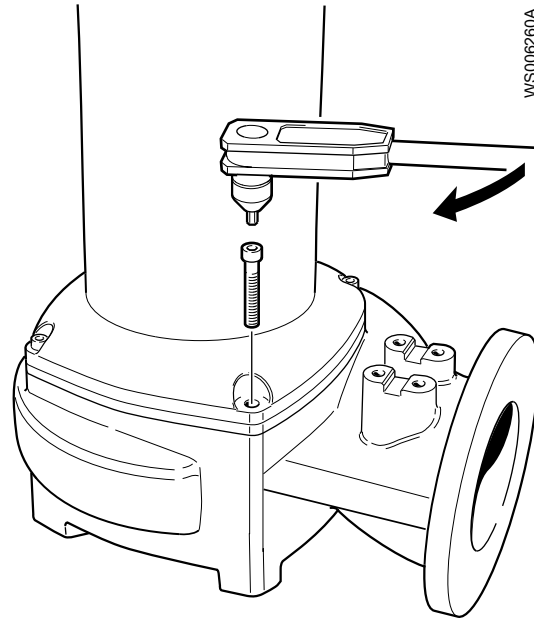

d) Check that the impeller can rotate freely.

If you must adjust the impeller, then perform *Replace the impeller* on page 61 again from the beginning.

### 6.6.3 Handle the screw unit

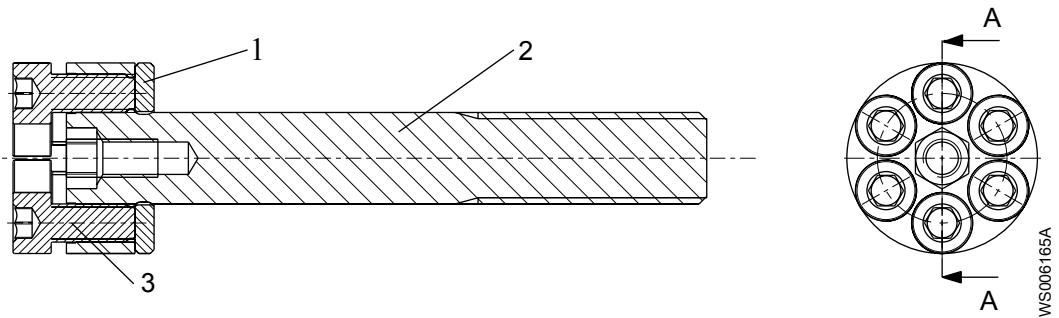

1. Washer
2. Center screw
3. Peripheral screws

---

#### NOTICE:

Avoid breaking the threads of the screws. Always make sure that the screws in the unit are removed or installed according to this procedure.

---

1. Remove the screw unit.
  - a) Loosen the peripheral screws in a star pattern.  
Each peripheral screw must, in every step, first be loosened and then fitted by hand until it touches the washer again.

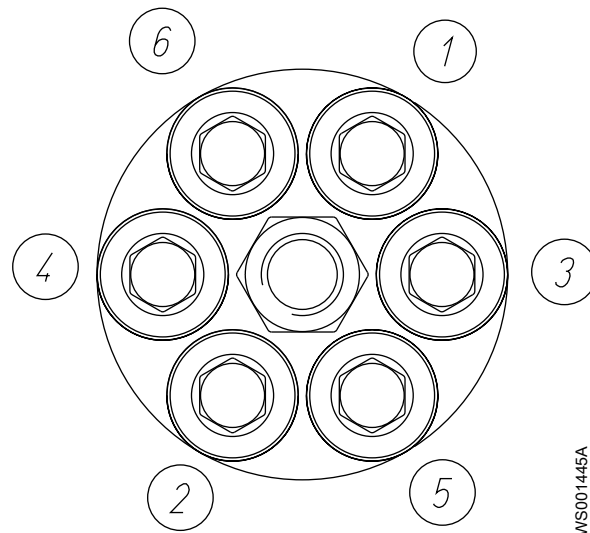

Figure 41: Star pattern for peripheral screws

- b) Repeat this procedure until there is no more load on the peripheral screws. Three or four repetitions are normally enough.
  - c) Remove the center screw.
2. Fit the screw unit.
- a) Make sure that all contact surfaces and threads are clean.
  - b) Lubricate all contact surfaces and threads with grease.
  - c) Unscrew the peripheral screws so they do not touch the washer.
  - d) Fit the screw unit to the shaft.
  - e) Tighten the center screw.  
Tightening torque: 100 Nm (74 ft-lb)
  - f) Tighten the peripheral screws in a star pattern.  
Repeat this procedure until the load is evenly distributed. Use the torque values in the following table.

Repetition	Tightening torque
1	12 Nm (8.9 ft-lb)
The following repetitions	24 Nm (18 ft-lb)

Three or four repetitions are normally enough.

## 6.7 Pumps with MAS 801: Replace the PEM

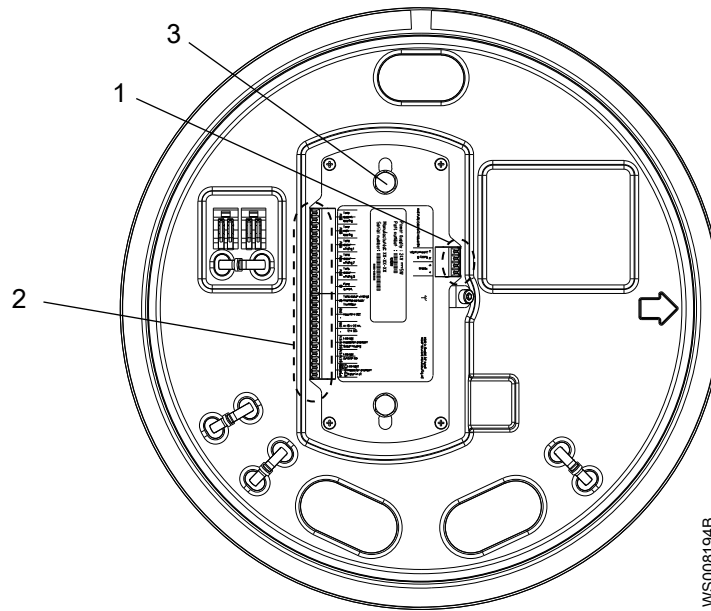

1. PEM communication terminals
2. PEM control terminals
3. Screws securing PEM

1. Disconnect the communication terminals.
2. Disconnect the control terminals on the PEM.  
For specially-approved pumps, do not disconnect T3 and T4 from the separate plinth.
3. Disconnect the functional ground.
4. Remove the two screws securing the PEM.
5. Lift out the PEM.
6. Fit the new PEM into place. Secure with two screws.
7. Connect the functional ground.
8. Connect the control terminals.  
For specially-approved pumps, do not use connections 51 and 63 on the PEM. For EX-pumps, T3 and T4 must be connected to the separate plinth.
9. Connect the communication terminals.
10. To download information to the PEM, see the System Installation and Operation (SIO) Manual for the MAS 801 monitoring equipment.

# 7 Troubleshooting

## 7.1 Electrical troubleshooting

EN



### **DANGER: Electrical Hazard**

Troubleshooting a live control panel exposes personnel to hazardous voltages. Electrical troubleshooting must be done by a qualified electrician.

Follow these guidelines when troubleshooting:

- Disconnect and lock out the power supply except when conducting checks that require voltage.
- Make sure that no one is near the unit when the power supply is reconnected.
- When troubleshooting electrical equipment, use the following:
  - Universal instrument multimeter
  - Test lamp (continuity tester)
  - Wiring diagram

## 7.2 The pump does not start



### **DANGER: Crush Hazard**

Moving parts can entangle or crush. Always disconnect and lock out power before servicing to prevent unexpected startup. Failure to do so could result in death or serious injury.



### **NOTICE:**

Do NOT override the motor protection repeatedly if it has tripped. Doing so may result in equipment damage.

Cause	Remedy
An alarm signal has been triggered on the control panel.	Check that: <ul style="list-style-type: none"> <li>• The impeller rotates freely.</li> <li>• The sensor indicators do not indicate an alarm.</li> <li>• The overload protection is not tripped.</li> </ul>
The pump does not start automatically, but can be started manually.	Check that: <ul style="list-style-type: none"> <li>• The start level regulator is functioning. Clean or replace if necessary.</li> <li>• All connections are intact.</li> <li>• The relay and contactor coils are intact.</li> <li>• The control switch (Man/Auto) makes contact in both positions.</li> </ul> Check the control circuit and functions.

Cause	Remedy
The installation is not receiving voltage.	Check that: <ul style="list-style-type: none"> <li>• The main power switch is on.</li> <li>• There is control voltage to the start equipment.</li> <li>• The fuses are intact.</li> <li>• There is voltage in all phases of the supply line.</li> <li>• All fuses have power and that they are securely fastened to the fuse holders.</li> <li>• The overload protection is not tripped.</li> <li>• The motor cable is not damaged.</li> </ul>
The impeller is stuck.	Clean: <ul style="list-style-type: none"> <li>• The impeller</li> <li>• The sump in order to prevent the impeller from clogging again.</li> </ul>

If the problem persists, then contact a sales or authorized service representative.

Always state the serial number of the product, see [Product Description](#) on page 10.

### 7.3 The pump does not stop when a level sensor is used



#### **DANGER: Crush Hazard**

Moving parts can entangle or crush. Always disconnect and lock out power before servicing to prevent unexpected startup. Failure to do so could result in death or serious injury.



Cause	Remedy
The pump is unable to empty the sump to the stop level.	Check that: <ul style="list-style-type: none"> <li>• There are no leaks from the piping and/or discharge connection.</li> <li>• The impeller is not clogged.</li> <li>• The non-return valve(s) are functioning properly.</li> <li>• The pump has adequate capacity. For information: Contact a sales or authorized service representative.</li> </ul>
There is a malfunction in the level-sensing equipment.	<ul style="list-style-type: none"> <li>• Clean the level regulators.</li> <li>• Check the functioning of the level regulators.</li> <li>• Check the contactor and the control circuit.</li> <li>• Replace all defective items.</li> </ul>
The stop level is set too low.	Raise the stop level.

If the problem persists, then contact a sales or authorized service representative.

Always state the serial number of the product, see [Product Description](#) on page 10.

### 7.4 The pump starts-stops-starts in rapid sequence

Cause	Remedy
The pump starts due to back-flow which fills the sump to the start level again.	Check that: <ul style="list-style-type: none"> <li>• The distance between the start and stop levels is sufficient.</li> <li>• The non-return valve(s) work(s) properly.</li> <li>• The length of the discharge pipe between the pump and the first non-return valve is sufficiently short.</li> </ul>

Cause	Remedy
The self-holding function of the contactor malfunctions.	Check: <ul style="list-style-type: none"> <li>The contactor connections.</li> <li>The voltage in the control circuit in relation to the rated voltages on the coil.</li> <li>The functioning of the stop-level regulator.</li> <li>Whether the voltage drop in the line at the starting surge causes the contactor's self-holding malfunction.</li> </ul>

If the problem persists, then contact a sales or authorized service representative.

Always state the serial number of the product, see [Product Description](#) on page 10.

## 7.5 The pump runs but the motor protection trips



### DANGER: Crush Hazard

Moving parts can entangle or crush. Always disconnect and lock out power before servicing to prevent unexpected startup. Failure to do so could result in death or serious injury.



### NOTICE:

Do NOT override the motor protection repeatedly if it has tripped. Doing so may result in equipment damage.

Cause	Remedy
The motor protection is set too low.	Set the motor protection according to the data plate and if applicable the cable chart.
The impeller is difficult to rotate by hand.	<ul style="list-style-type: none"> <li>Clean the impeller.</li> <li>Clean out the wet well.</li> <li>Check that the impeller is correctly trimmed.</li> </ul>
The drive unit cannot receive full voltage on all three phases.	<ul style="list-style-type: none"> <li>Check the fuses. Replace fuses that have tripped.</li> <li>If the fuses are intact, then notify a certified electrician.</li> </ul>
The phase currents change, or they are too high.	Contact a sales or authorized service representative.
The insulation between the phases and ground in the stator is defective.	<ol style="list-style-type: none"> <li>Use an insulation tester. Use a 1000 VDC insulation and continuity tester to check that the insulation between the phases, and between any phase and ground, is &gt; 5 megohms.</li> <li>If the insulation is less, then do the following: Contact a sales or authorized service representative.</li> </ol>
The density of the pumped fluid is too high.	Make sure that the maximum density is 1100 kg/m <sup>3</sup> (9.2 lb/US gal) <ul style="list-style-type: none"> <li>Change the impeller, or</li> <li>Change to a more applicable pump</li> <li>Contact a sales or authorized service representative.</li> </ul>
There is a malfunction in the overload protection.	Replace the overload protection.

If the problem persists, then contact a sales or authorized service representative.

Always state the serial number of the product, see [Product Description](#) on page 10.

## 7.6 The pump delivers too little or no water



### DANGER: Crush Hazard

Moving parts can entangle or crush. Always disconnect and lock out power before servicing to prevent unexpected startup. Failure to do so could result in death or serious injury.



### NOTICE:

Do NOT override the motor protection repeatedly if it has tripped. Doing so may result in equipment damage.

Cause	Remedy
The impeller rotates in the wrong direction.	<ul style="list-style-type: none"> <li>If it is a 3-phase pump, then transpose two phase leads.</li> <li>If it is a 1-phase pump, then do the following: Contact a sales or authorized service representative.</li> </ul>
One or more of the valves are set in the wrong positions.	<ul style="list-style-type: none"> <li>Reset the valves that are set in the wrong position.</li> <li>Replace the valves, if necessary.</li> <li>Check that all valves are correctly installed according to media flow.</li> <li>Check that all valves open correctly.</li> </ul>
The impeller is difficult to rotate by hand.	<ul style="list-style-type: none"> <li>Clean the impeller.</li> <li>Clean out the sump.</li> <li>Check that the impeller is properly trimmed.</li> </ul>
The pipes are obstructed.	To ensure a free flow, clean out the pipes.
The pipes and joints leak.	Find the leaks and seal them.
There are signs of wear on the impeller, pump, and casing.	Replace the worn parts.
The liquid level is too low.	<ul style="list-style-type: none"> <li>Check that the level sensor is set correctly.</li> <li>Depending on the installation type, add a means for priming the pump, such as a foot valve.</li> </ul>

If the problem persists, then contact a sales or authorized service representative. Always state the serial number of the product, see [Product Description](#) on page 10.

# 8 Technical Reference

## 8.1 Application limits

EN

Data	Description
Liquid temperature	40°C (104°F) maximum For P-installations without a cooling jacket, the pump can be operated only when the sump level is at least 10 mm (0.4 in) above the stator housing. Warm-liquid version: 70°C (158°F) maximum Warm-liquid version must have cooling jacket.
pH of the pumped media (liquid)	5.5–14
Liquid density	1100 kg/m <sup>3</sup> (9.2 lb for each US gal) maximum
Depth of immersion	Maximum 20 m (65 ft)
Other	For the specific weight, current, voltage, power ratings, and speed of the pump, see the data plate of the pump.

## 8.2 Motor data

Feature	Description
Motor type	Squirrel-cage induction
Frequency	50 Hz or 60 Hz
Supply	3-phase
Starting method	<ul style="list-style-type: none"> <li>• Direct on-line</li> <li>• Star-delta</li> <li>• Soft starter</li> <li>• Variable frequency drive (VFD)</li> </ul>
Maximum starts for each hour	15 evenly spaced starts for each hour
Code compliance	IEC 60034-1
Voltage variation without overheating	±10%, if it does not run continuously at full load
Voltage imbalance tolerance	2%
Stator insulation class	H (180°C [356°F])

### Motor encapsulation

Motor encapsulation is in accordance with IP68.

## 8.3 Sensor characteristics

Sensor	Measured value
Thermal contact	0–3 ohm unless the wires are long The thermal contacts open at 140°C (285°F)
Thermistor	Resistance at normal temperature: <ul style="list-style-type: none"> <li>• One thermistor, 50–100 ohm</li> <li>• Three thermistors in series, 150–300 ohm</li> </ul>

EN

Sensor	Measured value
Pt100	<ul style="list-style-type: none"> <li>• 100 ohm at 0°C (32°F)</li> <li>• 107.79 ohm at room temperature, 20°C (68°F)</li> <li>• 138.5 ohm at 100°C (212°F)</li> </ul> The resistance increases by 0.385 ohm for each °C.
FLS	<ul style="list-style-type: none"> <li>• Normal: 1530 ohm</li> <li>• Alarm: 330 ohm</li> </ul>
FLS10	<ul style="list-style-type: none"> <li>• Normal: 1200 ohm</li> <li>• Alarm: 430 ohm</li> </ul>

### 8.4 Wiring diagram: MiniCAS II

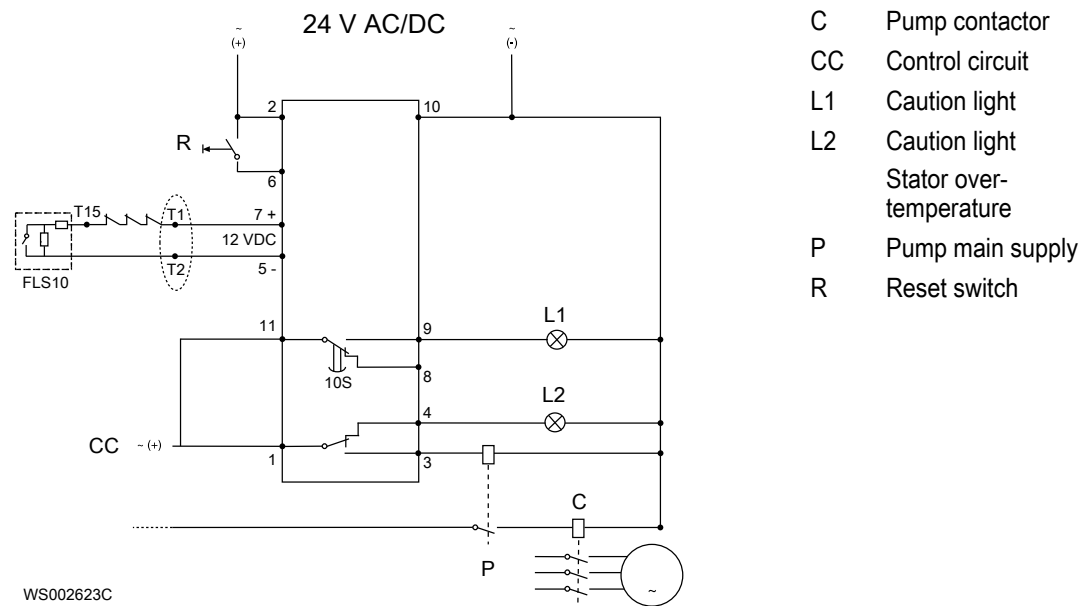



# Xylem |'zīləm|

- 1) The tissue in plants that brings water upward from the roots;
- 2) a leading global water technology company.

We're a global team unified in a common purpose: creating advanced technology solutions to the world's water challenges. Developing new technologies that will improve the way water is used, conserved, and re-used in the future is central to our work. Our products and services move, treat, analyze, monitor and return water to the environment, in public utility, industrial, residential and commercial building services settings. Xylem also provides a leading portfolio of smart metering, network technologies and advanced analytics solutions for water, electric and gas utilities. In more than 150 countries, we have strong, long-standing relationships with customers who know us for our powerful combination of leading product brands and applications expertise with a strong focus on developing comprehensive, sustainable solutions.

**For more information on how Xylem can help you, go to [www.xylem.com](http://www.xylem.com)**



Xylem Water Solutions Global  
Services AB 556782-9253  
361 80 Emmaboda  
Sweden  
Tel: +46-471-24 70 00  
Fax: +46-471-24 74 01  
<https://xapps.xylem.com/tpi>  
[www.xylemwatersolutions.com/contacts/](http://www.xylemwatersolutions.com/contacts/)

Visit our Web site for the latest version of this document and more information

The original instruction is in English. All non-English instructions are translations of the original instruction.

© 2011 Xylem Inc.

Service and Repair Instructions

885078\_8.0



# Flygt 3315



# Table of Contents

1	Introduction and Safety.....	3
1.1	Introduction.....	3
1.2	Safety terminology and symbols.....	3
1.3	User safety.....	4
1.4	Ex-approved products.....	4
1.5	Special hazards.....	5
1.5.1	Biological hazards.....	5
1.5.2	Wash the skin and eyes.....	6
1.6	Protecting the environment.....	6
1.7	End-of-life product disposal.....	6
1.8	Spare parts.....	6
1.9	Warranty.....	6
2	Product Description.....	7
2.1	Products included.....	7
2.2	The data plate.....	7
2.3	Approvals.....	8
2.4	Product denomination.....	9
3	Installation.....	11
3.1	Hazardous atmospheres.....	11
3.2	Make the electrical connections.....	11
3.2.1	General precautions.....	11
3.2.2	Grounding (earthing).....	12
3.2.3	Prepare the SUBCAB™ cables.....	13
3.2.4	Connect the motor cable to the pump.....	14
3.2.5	Connect the cables to the starter and monitoring equipment.....	17
3.3	Cable charts.....	18
3.3.1	Connection locations.....	19
3.4	MiniCAS.....	23
3.5	MAS 801.....	25
3.6	MAS 711.....	29
3.7	Check the impeller rotation.....	29
4	Maintenance.....	31
4.1	Precautions.....	31
4.2	Inspect the work area before permit-required hot work.....	31
4.3	Maintenance guidelines.....	31
4.4	Requirements for Ex-approved products.....	32
4.5	The fault-tracing process.....	32
4.5.1	Trace faults in the drive.....	32
4.5.2	Check the stator.....	33
4.6	Service the pump.....	34
4.6.1	Inspection.....	34
4.6.2	Overhaul.....	35
4.6.3	Service in case of alarm.....	35
4.7	Change the coolant.....	36
4.7.1	Empty the coolant.....	36
4.7.2	Fill with coolant.....	39
4.8	Disassemble the pump.....	40
4.8.1	Remove the connection housing.....	40

---

4.8.2	Remove the cooling jacket.....	42
4.8.3	Remove the impeller.....	44
4.8.4	Remove the impeller: wet installation.....	45
4.8.5	Remove the impeller: dry installation.....	47
4.8.6	Handle the screw unit.....	50
4.8.7	Remove the insert ring.....	51
4.8.8	Remove the mechanical seal.....	52
4.8.9	Remove the adapter.....	54
4.8.10	Remove the shaft unit.....	56
4.8.11	Remove the bearings.....	56
4.8.12	Remove the circlips.....	56
4.8.13	Remove the bearing holder.....	57
4.8.14	Remove the main bearing from the bearing holder.....	59
4.8.15	Remove the support bearing.....	60
4.9	Assemble the pump.....	60
4.9.1	Install the bearings.....	61
4.9.2	Install the support bearing.....	61
4.9.3	Install the main bearing in the bearing holder.....	61
4.9.4	Install the bearing holder.....	63
4.9.5	Fit the circlips.....	64
4.9.6	Install the shaft unit.....	66
4.9.7	Install the adapter.....	67
4.9.8	Install the mechanical seal.....	68
4.9.9	Check the seal tightness.....	71
4.9.10	Install the insert ring.....	72
4.9.11	Replace the impeller.....	72
4.9.12	Install the impeller: wet installation.....	72
4.9.13	Install the impeller: dry installation.....	75
4.9.14	Install the cooling jacket.....	82
4.9.15	Install the connection housing.....	84
4.10	Pumps with MAS 801: Replace the PEM.....	87
5	Troubleshooting.....	88
5.1	Electrical troubleshooting.....	88
5.2	The pump does not start.....	88
5.3	The pump does not stop when a level sensor is used.....	89
5.4	The pump starts-stops-starts in rapid sequence.....	89
5.5	The pump runs but the motor protection trips.....	90
5.6	The pump delivers too little or no water.....	91
6	Technical Reference.....	92
6.1	Application limits.....	92
6.2	Pump parts.....	92
6.3	Tools.....	95
6.4	Sensor characteristics.....	98
6.5	Wiring diagram: MiniCAS II.....	99
6.6	Torque values.....	99

# 1 Introduction and Safety

## 1.1 Introduction

### Purpose of the manual

The purpose of this manual is to provide the necessary information for working with the unit. Read this manual carefully before starting work.

### Read and keep the manual

Save this manual for future reference, and keep it readily available at the location of the unit.

### Intended use



#### **WARNING:**

Operating, installing, or maintaining the unit in any way that is not covered in this manual could cause death, serious personal injury, or damage to the equipment and the surroundings. This includes any modification to the equipment or use of parts not provided by Xylem. If there is a question regarding the intended use of the equipment, please contact a Xylem representative before proceeding.

### Other manuals

See also the safety requirements and information in the original manufacturer's manuals for any other equipment furnished separately for use in this system.



## 1.2 Safety terminology and symbols

### About safety messages

It is extremely important that you read, understand, and follow the safety messages and regulations carefully before handling the product. They are published to help prevent these hazards:



- Personal accidents and health problems
- Damage to the product and its surroundings
- Product malfunction

### Hazard levels

Hazard level	Indication
 <b>DANGER:</b>	A hazardous situation which, if not avoided, will result in death or serious injury
 <b>WARNING:</b>	A hazardous situation which, if not avoided, could result in death or serious injury
 <b>CAUTION:</b>	A hazardous situation which, if not avoided, could result in minor or moderate injury
<b>NOTICE:</b>	Notices are used when there is a risk of equipment damage or decreased performance, but not personal injury.

## Special symbols

Some hazard categories have specific symbols, as shown in the following table.

Electrical hazard	Magnetic fields hazard
 <p>Electrical Hazard:</p>	 <p>CAUTION:</p>

## 1.3 User safety

All regulations, codes, and health and safety directives must be observed.

### The site

- Observe lockout and tagout procedures before starting work on the product, such as transportation, installation, maintenance, or service.
- Pay attention to the risks presented by gas and vapors in the work area.
- Always be aware of the area surrounding the equipment, and any hazards posed by the site or nearby equipment.

### Qualified personnel

This product must be installed, operated, and maintained by qualified personnel only.

### Protective equipment and safety devices

- Use personal protective equipment as needed. Examples of personal protective equipment include, but are not limited to, hard hats, safety goggles, protective gloves and shoes, and breathing equipment.
- Make sure that all safety features on the product are functioning and in use at all times when the unit is being operated.

## 1.4 Ex-approved products

Follow these special handling instructions if you have an Ex-approved unit.

### Personnel requirements

These are the personnel requirements for Ex-approved products in potentially explosive atmospheres:

- All work on the product must be carried out by certified electricians and Xylem authorized mechanics. Special rules apply to installations in explosive atmospheres.
- All users must know about the risks of electric current and the chemical and physical characteristics of the gas, the vapor, or both present in hazardous areas.
- Any maintenance for Ex-approved products must conform to international and national standards (for example, IEC/EN 60079-17).

Xylem disclaims all responsibility for work done by untrained and unauthorized personnel.

### Product and product handling requirements

These are the product and product handling requirements for Ex-approved products in potentially explosive atmospheres:

- Only use the product in accordance with the approved motor data.
- The equipment must never run dry during operation. The volute must be filled with liquid during operation. Dry running during service and inspection is only permitted outside the classified area.
- Before you start work on the product, make sure that the product and the control panel are isolated from the power supply and the control circuit, so they cannot be energized.
- Do not open the product while it is energized or in an explosive gas atmosphere.

- Intrinsically safe circuits are normally required for the automatic level-control system by the level regulator if mounted in zone 0.
- The yield stress of fasteners must be in accordance with the approval drawing and the product specification.
- Do not modify the equipment without approval from an Ex-approved Xylem representative.
- Only use original Xylem spare parts that are provided by an Ex-approved Xylem representative.
- The thermal contacts that are fitted to the stator windings must be connected correctly to a separate motor control circuit and in use. The thermal contacts shall be connected to a monitoring device, which disconnects the power supply immediately upon activation. This action prevents the rise of temperatures above the temperature value for the approval classification.
- The width of flameproof joints is more than the values specified in the tables of the EN/IEC 60079-1 standard. For information contact the manufacturer.
- The gap of flameproof joints is less than the values specified in Table 2 of the EN/IEC 60079-1 standard. For information contact the manufacturer.
- It is NOT allowed to repair the flameproof joints.
- Ambient temperature:  $-20^{\circ}\text{C}$  to  $60^{\circ}\text{C}$

### Guidelines for compliance

Compliance is fulfilled only when you operate the unit within its intended use. Do not change the conditions of the service without the approval of an Ex-approved Xylem representative. When you install or maintain explosion proof products, always comply with the directive and applicable standards (for example, IEC/EN 60079–14).

### Minimum permitted liquid level

See the dimensional drawings of the product for the minimum permitted liquid level according to the approval for explosion proof products. If the information is missing on the dimensional drawing, the product must be fully submerged. Level-sensing equipment must be installed if the product can be operated at less than the minimum submersion depth.

### Monitoring equipment

For additional safety, use condition-monitoring devices. Examples of condition-monitoring devices include, but are not limited to, the following:

- Level indicators
- Temperature detectors in addition to the stator thermal detectors

Any thermal detectors or thermal protection devices delivered with the pump must be installed and in use at all times.

The site owner is responsible for selection, installation, and proper maintenance of functional monitoring equipment for motor protection.

## 1.5 Special hazards

### 1.5.1 Biological hazards

The product is designed for use in liquids that can be hazardous to your health. Observe these rules when you work with the product:

- Make sure that all personnel who may come into contact with biological hazards are vaccinated against diseases to which they may be exposed.
- Observe strict personal cleanliness.



---

#### **WARNING: Biological Hazard**

Infection risk. Rinse the unit thoroughly with clean water before working on it.

---

## 1.5.2 Wash the skin and eyes

Follow these procedures for chemicals or hazardous fluids that have come into contact with your eyes or your skin:

Condition	Action
Chemicals or hazardous fluids in eyes	<ol style="list-style-type: none"> <li>1. Hold your eyelids apart forcibly with your fingers.</li> <li>2. Rinse the eyes with eyewash or running water for at least 15 minutes.</li> <li>3. Seek medical attention.</li> </ol>
Chemicals or hazardous fluids on skin	<ol style="list-style-type: none"> <li>1. Remove contaminated clothing.</li> <li>2. Wash the skin with soap and water for at least 1 minute.</li> <li>3. Seek medical attention, if necessary.</li> </ol>

## 1.6 Protecting the environment

### Emissions and waste disposal

Observe the local regulations and codes regarding:

- Reporting of emissions to the appropriate authorities
- Sorting, recycling and disposal of solid or liquid waste
- Clean-up of spills

### Exceptional sites



#### CAUTION: Radiation Hazard

Do NOT send the product to Xylem if it has been exposed to nuclear radiation, unless Xylem has been informed and appropriate actions have been agreed upon.

## 1.7 End-of-life product disposal

Handle and dispose of all waste in compliance with local laws and regulations.

### EU and UK only: Correct disposal of this product — waste electrical and electronic equipment

- EU: Directive 2012/19/EU on waste electrical and electronic equipment (WEEE)
- UK: SI 2013 No. 3113



WSD00973B

This marking on the product, accessories or literature indicates that the product should not be disposed of with other waste at the end of its working life.

## 1.8 Spare parts



#### CAUTION:

Only use the manufacturer's original spare parts to replace any worn or faulty components. The use of unsuitable spare parts may cause malfunctions, damage, and injuries as well as void the warranty.

## 1.9 Warranty

For information about warranty, see the sales contract.

# 2 Product Description

## 2.1 Products included

Pump model	Standard version Non-explosion proof	Explosion proof version	N-hydraulic	Impeller material		
				Gray iron	Hard-Iron™	Stainless steel
3315.090		X	X	X		
3315.095		X	X		X	
3315.180	X		X	X		
3315.185	X		X		X	
3315.660	X		X			X
3315.670		X	X			X

### Pump-specific information

For the specific weight, current, voltage, power ratings, and speed of the pump, see the data plate.

## 2.2 The data plate

The data plate is a metal label that is located on the main body of the products. The data plate lists key product specifications. Specially approved products also have an approval plate.

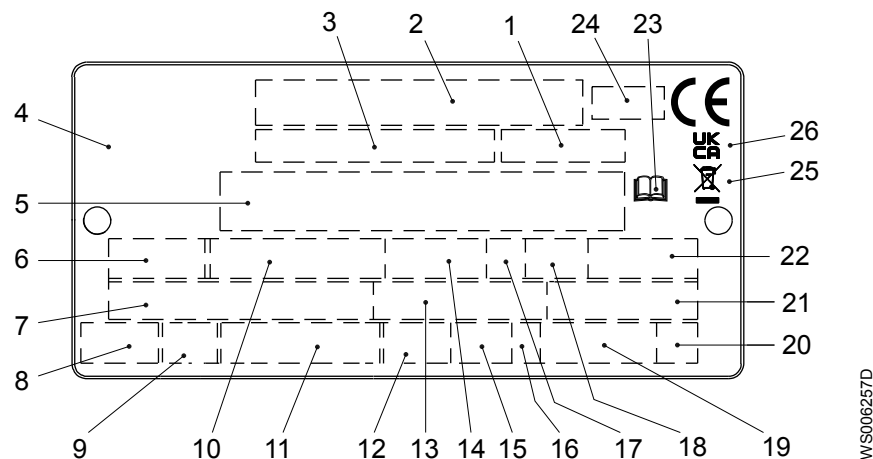

1. Curve code or Propeller code
2. Serial number
3. Product number
4. Country of origin
5. Additional information
6. Phase; type of current; frequency
7. Rated voltage
8. Thermal protection
9. Thermal class
10. Rated shaft power
11. International standard
12. Degree of protection
13. Rated current
14. Rated speed
15. Maximum submergence

WS006257D

- 16. Direction of rotation: L=left, R=right
- 17. Duty class
- 18. Duty factor
- 19. Product weight
- 20. Locked rotor code letter
- 21. Power factor
- 22. Maximum ambient temperature
- 23. Read installation manual
- 24. Notified body, only for EN-approved Ex products
- 25. WEEE-Directive symbol
- 26. UKCA marking

Figure 1: The data plate



## 2.3 Approvals

### Product approvals for hazardous locations

#### 3315

This table shows product approvals for the following products:

- 3315.090
- 3315.095
- 3315.670

Type	Approval
European Norm (EN)	<ul style="list-style-type: none"> <li>• ATEX Directive</li> <li>• EN IEC 60079-0:2018, EN 60079-1:2014, EN ISO 80079-36:2016, EN ISO 80079-37:2016</li> <li>•  II 2 G Ex db h IIB T3 Gb</li> </ul>
IEC	<ul style="list-style-type: none"> <li>• IECEx scheme</li> <li>• IEC 60079-0:2017, IEC 60079-1:2014-06, ISO 80079-36:2016, ISO 80079-37:2016</li> <li>• Ex db h IIB T3 Gb</li> </ul>
FM (FM Approvals)	<ul style="list-style-type: none"> <li>• Explosion proof for use in Class I, Div. 1, Group C and D</li> <li>• Dust ignition proof for use in Class II, Div. 1, Group E, F and G</li> <li>• Suitable for use in Class III, Div. 1, Hazardous Locations</li> </ul>
CSA Ex	<ul style="list-style-type: none"> <li>• Explosion proof for use in Class I, Div. 1, Group C and D</li> </ul>
UKEx	<ul style="list-style-type: none"> <li>• UK SI 2016 No. 1107</li> <li>• EN IEC 60079-0:2018, EN 60079-1:2014, EN ISO 80079-36:2016, EN ISO 80079-37:2016</li> <li>•  II 2 G Ex db h IIB T3 Gb</li> </ul>

### EN approval plate

This illustration describes the EN approval plate and the information that is contained in its fields.

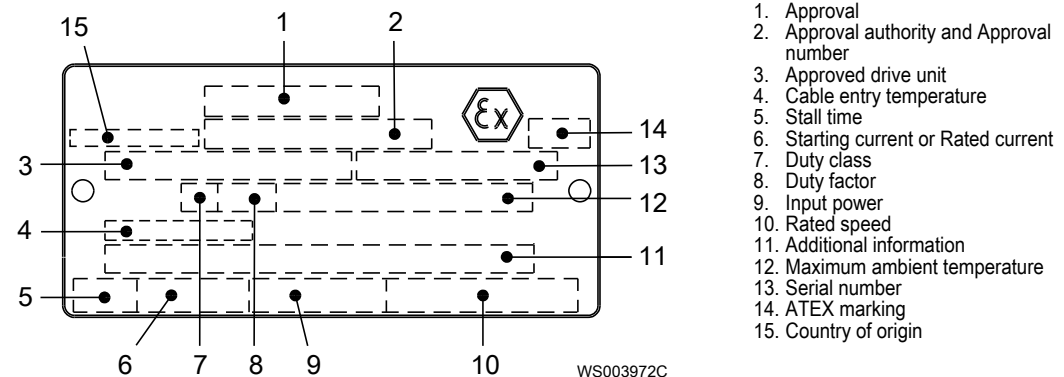

## IEC approval plate

This illustration describes the IEC approval plate and the information that is contained in its fields.

International Norm; not for EU member countries.

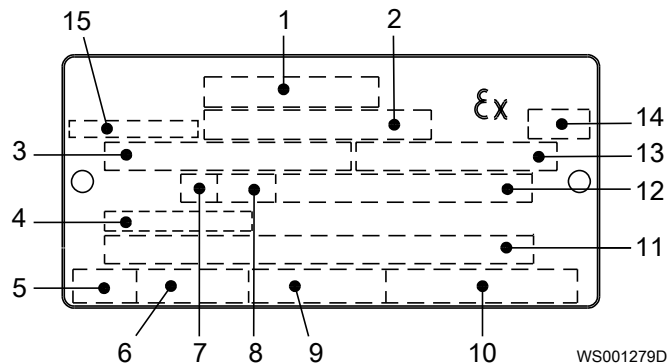

1. Approval
2. Approval authority and Approval number
3. Approved drive unit
4. Cable entry temperature
5. Stall time
6. Starting current or Rated current
7. Duty class
8. Duty factor
9. Input power
10. Rated speed
11. Additional information
12. Maximum ambient temperature
13. Serial number
14. ATEX marking
15. Country of origin

## FM approval plate

This illustration describes the FM approval plate and the information that is contained in its fields.

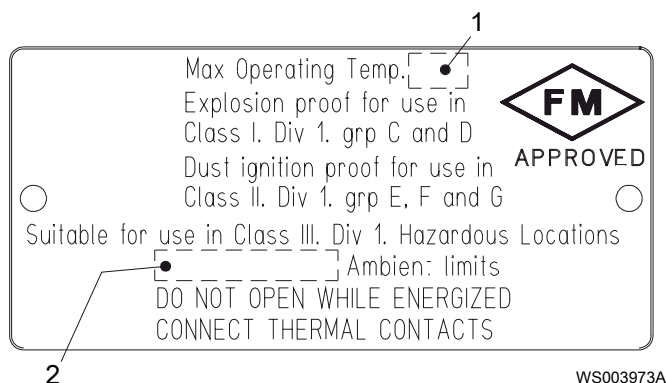

1. Temperature class
2. Maximum ambient temperature

## CSA approval plate

This illustration describes the CSA approval plate and the information that is contained in its fields.

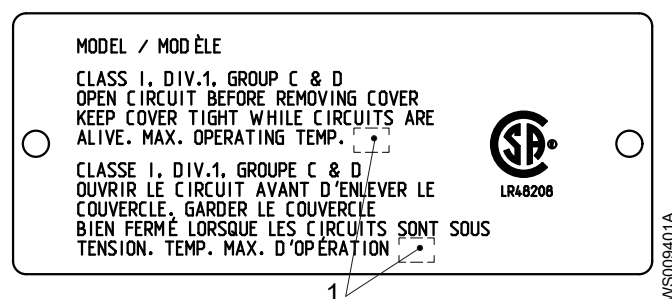

1. Temperature class

## 2.4 Product denomination

### Reading instruction

In this section, code characters are illustrated accordingly:

X = letter

Y = digit

The different types of codes are marked up with a, b and c. Code parameters are marked up with numbers.

**Codes and parameters**

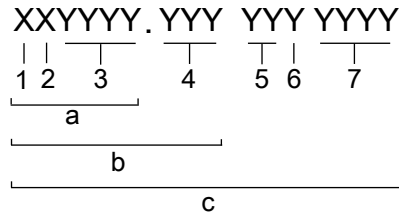

WS006265B

Type of Callout	Number	Indication
Type of code	a	Sales denomination
	b	Product code
	c	Serial number
Parameter	1	Hydraulic end
	2	Type of installation
	3	Sales code
	4	Version
	5	Production year
	6	Production cycle
	7	Running number

# 3 Installation

## 3.1 Hazardous atmospheres



---

### **DANGER: Explosion/Fire Hazard**

Special rules apply to installations in explosive or flammable atmospheres. Do not install the product or any auxiliary equipment in an explosive zone unless it is rated explosion-proof or intrinsically-safe. If the product is rated explosion-proof or intrinsically-safe, then see the specific explosion-proof information in the safety chapter before taking any further actions.

---

## 3.2 Make the electrical connections

### 3.2.1 General precautions



---

### **DANGER: Electrical Hazard**

Before starting work on the unit, make sure that the unit and the control panel are isolated from the power supply and cannot be energized. This applies to the control circuit as well.



---

### **WARNING: Electrical Hazard**

Risk of electrical shock or burn. A certified electrician must supervise all electrical work. Comply with all local codes and regulations.

---



---

### **WARNING: Electrical Hazard**

There is a risk of electrical shock or explosion if the electrical connections are not correctly carried out, or if there is fault or damage on the product. Visually inspect equipment for damaged cables, cracked casings or other signs of damage. Make sure that electrical connections have been correctly made.

---



---

### **WARNING: Crush Hazard**

Risk of automatic restart.

---



---

### **CAUTION: Electrical Hazard**

Prevent cables from becoming sharply bent or damaged.

---



---

### **NOTICE:**

Leakage into the electrical parts can cause damaged equipment or a blown fuse. Keep the cable ends dry at all times.

---

### Requirements

These general requirements apply for the electrical installation:

- If the pump will be connected to the public mains, then the supply authority must be notified before installing the pump. When the pump is connected to the public power supply, it can cause flickering of incandescent lamps when started.
- The mains voltage and frequency must agree with the specifications on the data plate. If the pump can be connected to different voltages, then follow the specified voltage on the yellow sticker close to the cable entry.
- If the operation can be intermittent, such as S3 periodic duty, then the pump must be supplied with monitoring equipment supporting such operation.
- If stated on the data plate, then the motor is convertible between different voltages.
- The thermal contacts or thermistors must be in use.
- For FM-approved pumps, a leakage sensor must be connected and in use to meet approval requirements.

### Motor and short-circuit protection

---

#### NOTICE:

A qualified electrician must select the size of motor protection breakers and fuses. The size must be chosen for the specific motor data such as rated current and starting current.

It is important that the short-circuit protection is not over-dimensioned. Over-dimensioned fuses or motor protection breakers decrease the protection for the motor.

---

- The fuse rating and the cables must be in accordance with the local rules and regulations.
- The fuses and circuit breakers must have the correct rating.
- The pump overload protection must be connected and set to the rated current.

The starting current in direct-on-line start can be up to six times higher than the rated current.

For more information, see the data plate and if applicable, the cable chart for the rated current.

### Cables

When cables are installed, these requirements must be followed:

- The cables must be in good condition, not have any sharp bends, and not be pinched.
- The cables must not be damaged and must not have indentations.
- The cables must not be embossed at the cable entry.
- The cable entry seal sleeve and washers must conform to the outer diameter of the cable.
- The minimum bend radius must not be smaller than the accepted value.
- If a cable is reused, a short piece at the end must be peeled off when the cable is refitted. This action is necessary so that the seal sleeve of the cable entry does not close around the cable at the same point again. If the outer jacket of the cable is damaged, then the cable must be replaced.

Contact a sales or authorized service representative.

- The voltage drop in long cables must be considered. The rated voltage of the drive unit is the voltage that is measured at the cable connection point in the pump.
- If a variable frequency drive (VFD) is used, the screened cable must be used according to the European CE and EMC requirements. For more information, contact a sales or authorized service representative.
- The cable length must be long enough for maintenance work.
- For SUBCAB™ cables, the twisted pair copper foil must be trimmed.
- All unused conductors must be insulated.

### 3.2.2 Grounding (earthing)

Grounding (earthing) must be done in compliance with all local codes and regulations.

**DANGER: Electrical Hazard**

All electrical equipment must be grounded (earthed). Test the ground (earth) lead to verify that it is connected correctly and that the path to ground is continuous.

**WARNING: Electrical Hazard**

Risk of electrical shock. The ground (earth) lead must be sufficiently longer than the phase leads to make sure that the ground lead is the last to become disconnected if the cable is jerked loose.

**WARNING: Electrical Hazard**

Risk of electrical shock or burn. You must connect an additional ground- (earth-) fault protection device to the grounded (earthed) connectors if persons are likely to come into contact with liquids that are also in contact with the pump or pumped liquid.

### 3.2.3 Prepare the SUBCAB™ cables

This section applies to SUBCAB™ cables with twisted-pair control conductors.

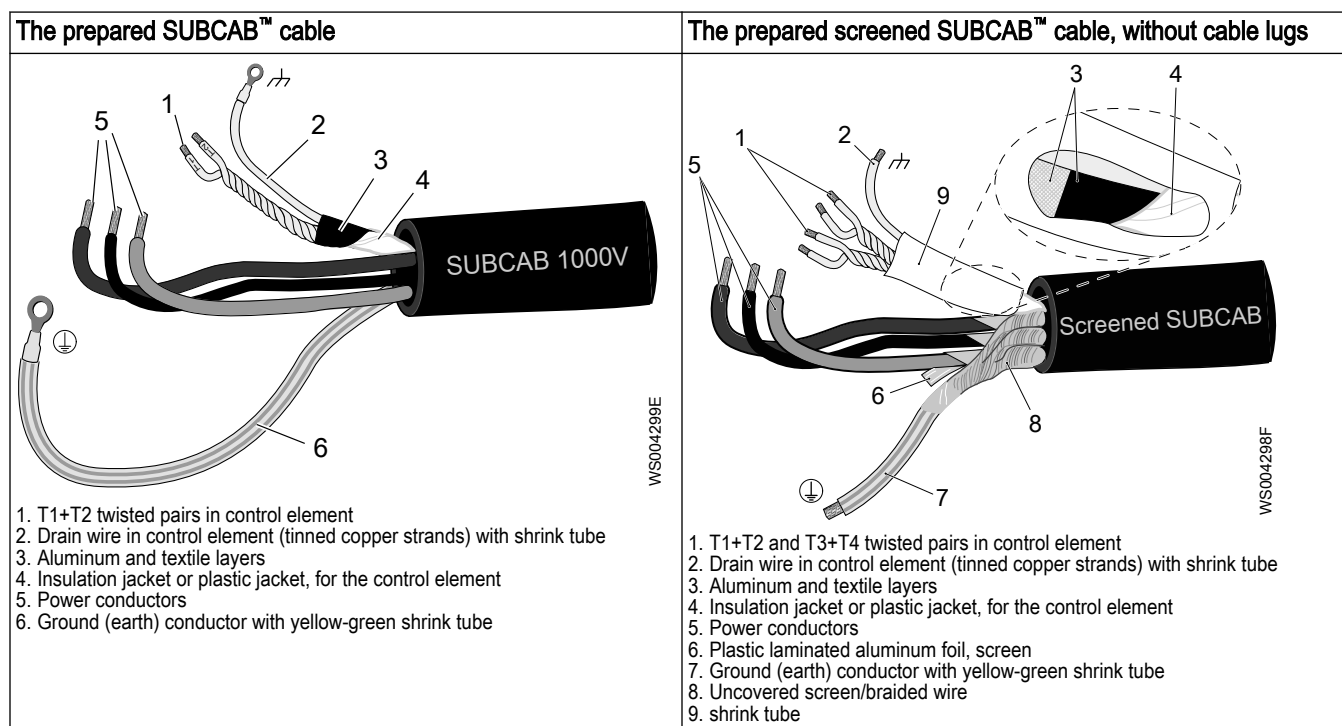

1. Peel off the outer jacket at the end of the cable.
2. Prepare the control element:
  - a) Peel the insulation jacket or plastic jacket.
  - b) Peel the aluminum and textile layers.

The aluminum foil is a conductive screen. Do not peel more than necessary, and remove the peeled foil.

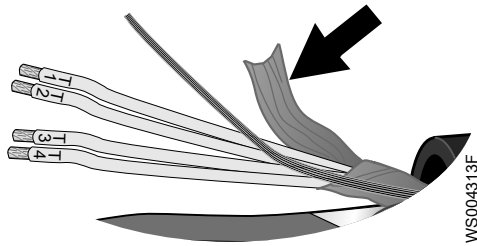

Figure 2: Aluminum foil on the control element.

- c) Put a white shrink tube over the drain wire.
- d) Twist T1+T2 and T3+T4.
- e) Put a shrink tube over the control element.

Make sure that the conductive aluminum foil and drain wire are covered.

3. Prepare the ground (earth) conductor of the SUBCAB™ cable:
  - a) Peel the yellow-green insulation from the ground (earth) conductor.
  - b) Check that the ground (earth) conductor is at least 10% longer than the phase conductors in the cabinet.
  - c) If applicable, put a cable lug on the ground conductor.
4. Prepare the ground (earth) conductor of the screened SUBCAB™ cable:
  - a) Untwist the screens around the power conductors.
  - b) Twist all power conductor screens together to create a ground (earth) conductor.
  - c) Put a yellow-green shrink tube over the ground (earth) conductor.  
Leave a short piece uncovered.
  - d) Check that the connected ground (earth) conductor has sufficient slack. The conductor must stay connected even if the power conductors are pulled loose.
5. Prepare the power conductors:
  - a) Remove the aluminum foil around each power conductor.
  - b) Peel the insulation from each power conductor.
6. Prepare the ends of the ground (earth) conductor, the power conductors, and the drain wire:

Connection type	Action
Screw	Fit cable lugs to the ends.
Terminal block	Fit end sleeves or leave the ends as they are.

### 3.2.4 Connect the motor cable to the pump

If the motor cable is not already connected to the pump, then connect it by following this procedure.

**NOTICE:**

Leakage into the electrical parts can cause damaged equipment or a blown fuse. Keep the end of the motor cable dry at all times.

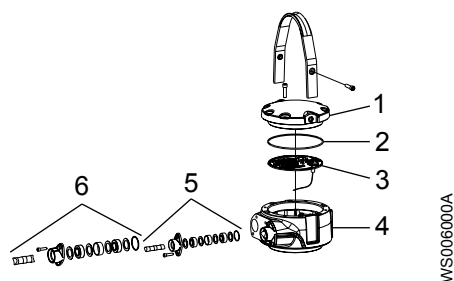

1. Cover
2. O-ring
3. Terminal plate with terminal board
4. Connection housing
5. Monitoring cable entry
6. Motor cable entry

For more information about the cable entry, see the Parts List.

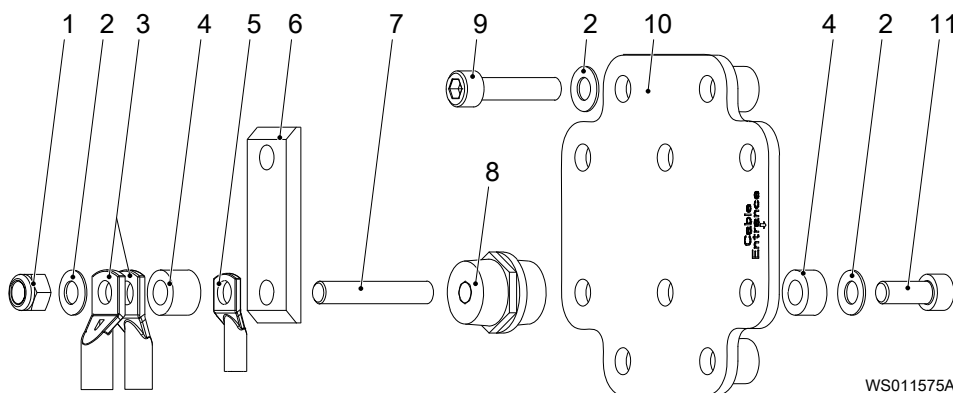

1. Nut
  2. Disc spring
  3. Cable lug for phase lead
  4. Standoff
  5. Cable lug for stator lead
  6. Closing link, generic illustration
  7. Stud
- Tightening torque: 22.0±2.2 Nm (16.2±1.6 lbf-ft)
8. Insulator
  9. Screw for the terminal board
  10. Terminal board 834 57 xx
  11. Screw for insulator
- Tightening torque: 44.0±4.4 Nm (32.5±3.2 lbf-ft)

Figure 3: Terminal board 834 57 xx

1. Remove the cover and the O-ring from the connection housing.
2. Replace the terminal board, if necessary:
  - a) Remove all connections to the old terminal board. Remove the old terminal board.
  - b) Examine the new terminal board assembly. If applicable, then tighten to the correct torques.
  - c) Install the terminal board.  
Tightening torque: 44.0±4.4 Nm (32.5±3.2 lbf-ft)
  - d) Apply the closing links.
3. Install cable lugs and insulate the cable ends of the power leads:

Insulation option	Actions
Shrink hose 94 03 30 or 95 00 32	<ol style="list-style-type: none"> <li>1. Fit 50 mm (2 in) of a shrink hose with the correct dimensions over the cable.</li> <li>2. Move the shrink hose away from the cable end.</li> <li>3. Crimp the cable lug on the cable end. Use calibrated crimp tools according to the specified standard for the cable lug.</li> <li>4. Push the shrink hose over the cable lug as far as possible. Use heat to shrink the shrink hose over the cable lug and the cable end.</li> </ol>

Insulation option	Actions
Self-vulcanizing tape 94 02 62	<ol style="list-style-type: none"> <li>1. Crimp the cable lug on the cable end. Use calibrated crimp tools according to the specified standard for the cable lug.</li> <li>2. Stretch the self-vulcanizing tape until the oval markings become circular.</li> <li>3. Apply the tape with at least 50% overlap for every turn.</li> <li>4. Apply the tape over the cable lug and over at least 30 mm (1.2 in) of the exposed cable.</li> </ol>

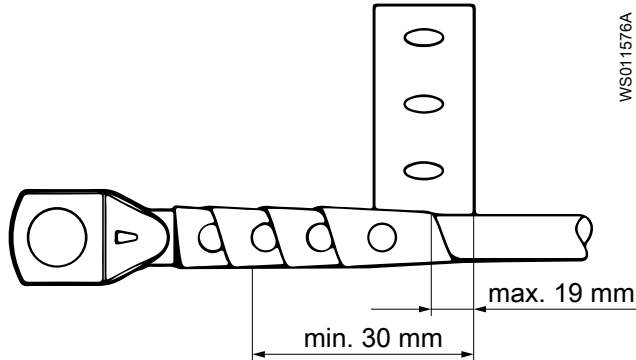

Figure 4: Application of self-vulcanizing tape

4. Examine the data plate to see which connections are required for the power supply.
5. Arrange the connections to the terminal board in accordance with the required power supply.
6. Connect the mains leads: L1, L2, L3, and ground (earth). See the applicable cable chart. The ground (earth) lead must be longer than the phase leads in the junction box of the pump. The following table shows how much extra length is required for the ground (earth) lead.

Pump	Extra length required for the ground (earth) lead	
	Millimeters	Inches
3315	150	6.0

- Install the parts in the correct order.
- Make sure that all cable ends point 90° away from the cable entrance.
- Make sure that the chamfers of the cable lugs are turned in the correct directions.
- Make sure that the convex surfaces of the disc springs face the nuts and the screws.
- Tighten the nuts.

Tightening torque: 35±3.5 Nm (26±2.6 lbf-ft)

Generic illustration

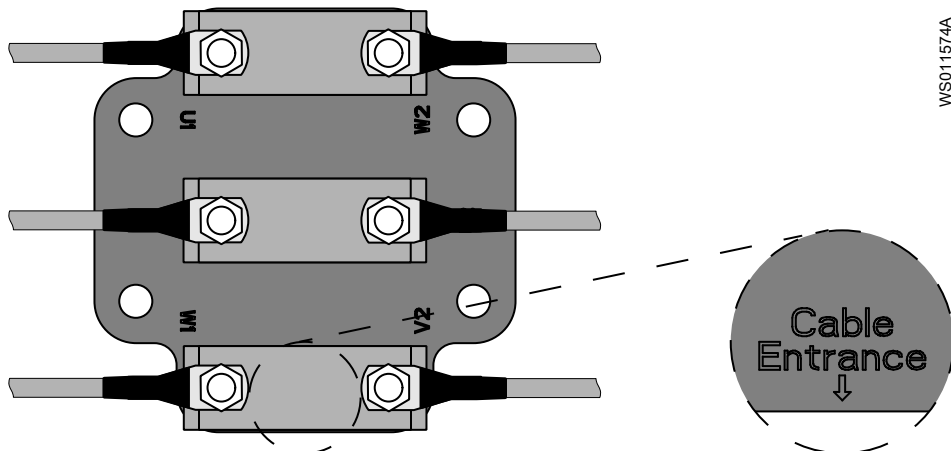

7. Make sure that the pump is correctly connected to ground (earth).
8. Connect the control leads to the applicable terminal board on the terminal plate.
9. Make sure that any thermal contacts incorporated in the pump are properly connected to the terminal board.
10. Install the cover and the O-ring.
11. Fasten the screws on the entrance flange so that the cable insertion assembly bottoms out.

### 3.2.5 Connect the cables to the starter and monitoring equipment

If there are two power cables, then the cable that is connected to T1 and T2 is labeled. If a separate control cable is used, then the control leads in the power cable are never connected.



---

#### **DANGER: Explosion/Fire Hazard**

Special rules apply to installations in explosive or flammable atmospheres. Do not install the product or any auxiliary equipment in an explosive zone unless it is rated explosion-proof or intrinsically-safe. If the product is rated explosion-proof or intrinsically-safe, then see the specific explosion-proof information in the safety chapter before taking any further actions.

---

#### **NOTICE:**

Either thermal contacts or thermistors are incorporated in the pump.

---

#### **NOTICE:**

Thermal contacts must never be exposed to voltages higher than 250 V, breaking current maximum 4 A.

---

#### 3.2.5.1 Connect the sensor leads: MiniCAS II

1. Connect the sensor leads.

Option	Description
Thermal contacts	Connect the T1 and T2 sensor leads to the MiniCAS II.
Thermistors, screened cable	Connect the T1 and T2 sensor leads to the thermistor relay. Connect the T3 and T4 sensor leads to the MiniCAS II.
Thermistors, auxiliary cable	Connect the sensor leads 1 and 2 to the thermistor relay. Connect the sensor leads 3 and 4 to the MiniCAS II.

For more information, see [MiniCAS](#) on page 23.

2. Insulate the unused leads.

#### 3.2.5.2 Connect the auxiliary cable: MAS 711

1. Connect the 12-lead SUBCAB cable, or the 24-lead cable, to the monitoring equipment.  
For more information, see [MAS 711](#) on page 29.
2. Insulate the unused leads.

#### 3.2.5.3 Connect the sensor leads: MAS 801

1. Connect T1 and T2 to the MAS BU.
2. Connect the functional ground to the MAS BU.
3. For Ex-applications, connect T3 and T4 from the thermal contacts or thermistors.  
The stator winding temperature sensors are connected to the T3 and T4 terminals on the separate plinth.

Option	Description
Thermal contacts	Connect the thermal contacts in the contactor coil circuit so that the circuit breaks directly. Use an auxiliary relay for the thermal contact status signals.
Thermistors	Connect the leads to a SIL-approved thermistor relay.

For more information, see [MAS 801](#) on page 25.

### 3.2.5.4 Connect the power leads

1. Connect the mains leads (L1, L2, L3, and ground (earth)) to the starter equipment.  
For information about the phase sequence and the color codes of the leads, see Cable charts.
2. Make sure that the warning label is attached to the cable end.  
The label is delivered with pumps that are equipped with permanent magnet synchronous motor. If the label is missing, attach the spare label to the cable end.

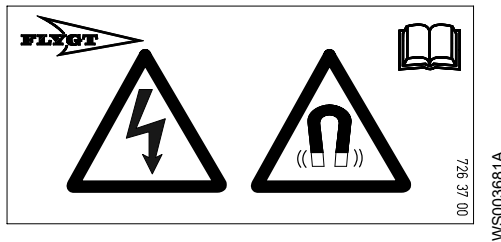

3. Check the functionality of the monitoring equipment:
  - a) Check that the signals and the tripping function work correctly.
  - b) Check that the relays, lamps, fuses, and connections are intact.
 Replace any defective equipment.

## 3.3 Cable charts

### Description

This topic contains general connection information. It also provides cable charts that show connection alternatives for use with different cables and power supply.

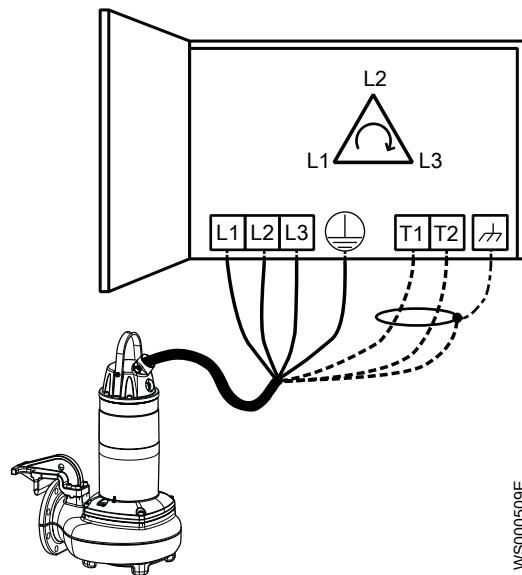
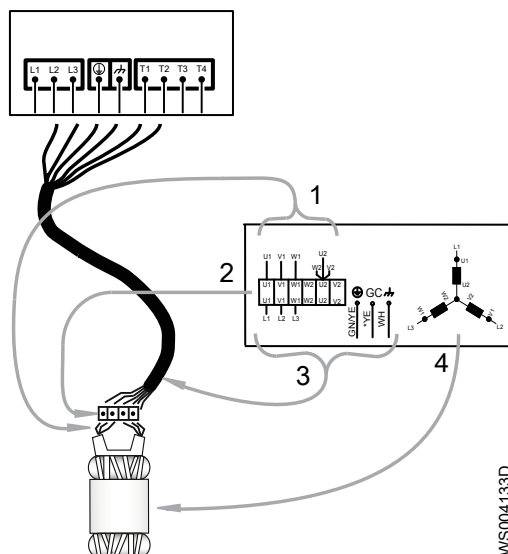

Figure 5: Phase sequence

### 3.3.1 Connection locations

The figures in this section illustrate how to interpret the connection strip symbols.



1. Stator leads
2. Terminal board
3. Power cable leads
4. Stator (internal connection illustrated)

WS004133D

### Colors and markings of leads

MOTOR CONNECTION COLORS AND MARKING OF MAIN LEADS		773 30 00 (REV 5)					
COLOR STANDARD	STATOR LEAD COLORS	MOTOR CABLE LEAD COLORS AND MARKING					
BK - Black	LV Stators U1 - RD	MV Stators U - BK	3 ~	SUBCAB	SUBCAB AWG	SUBCAB S6x95+95+S(4x0.5)	MV cables
BN - Brown	U2 - GN	V - BK	L1	BN	RD	1 WH , 4 WH	BK
BU - Blue	V1 - BN	W - BK	L2	BK	BK	2 WH , 5 WH	BK
GN - Green	V2 - BU		L3	GY	WH	3 WH , 6 WH	BK
GN/YE - Green/Yellow	W1 - YE		T1, T2	WH	WH	WH	-
GY - Grey	W2 - BK		T3, T4	WH	WH	WH	-
OG - Orange	VOLTAGE DENOMINATIONS		⊕	GN/YE	GN/YE	GN/YE	GN/YE
RD - Red	LV - Low voltage		⚡	WH	-	WH	WH
WH - White	MV - Medium voltage		GC	-	YE	-	-
YE - Yellow							

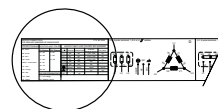

WS004335D







### Color code standard

Code	Description
BN	Brown
BK	Black
WH	White
OG	Orange
GN	Green
GNYE	Green-Yellow
RD	Red
GY	Grey
BU	Blue
YE	Yellow

### Connections included

- [Stator leads connection to terminal board](#) on page 20
- [3-phase connection](#) on page 21
- [3-phase connection, screened](#) on page 22

**Stator leads connection to terminal board**

 Terminal board	Stator leads connection to terminal board			
	3 leads Y	6 leads D	6 leads Y	6 leads Y/D
U1	U	 U1	U1	U1
V1	V	 V1	V1	V1
W1	W	 W1	W1	W1
W2	-	 W2	W2	W2
U2	-	 U2	U2	U2
V2	-	 V2	V2	V2

WS007848A

3-phase connection

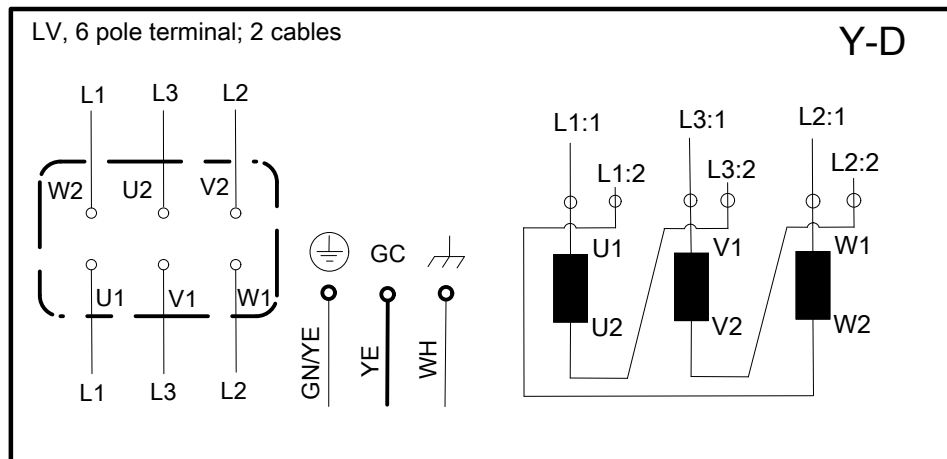
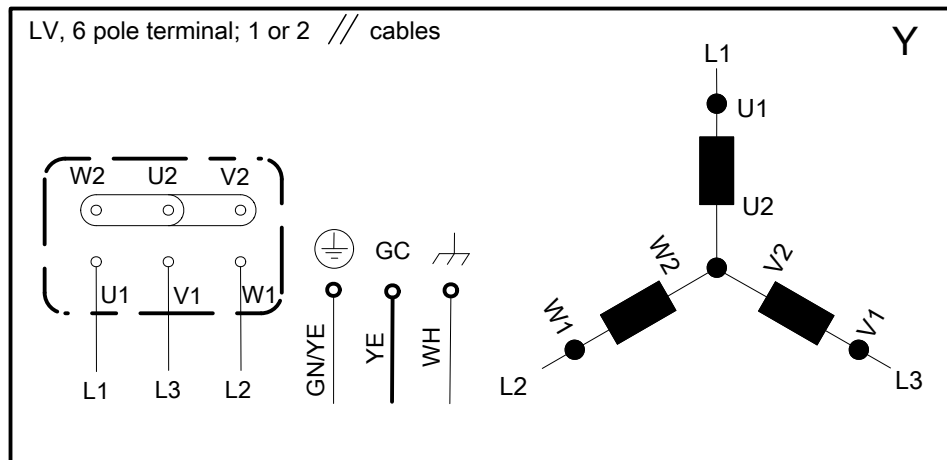
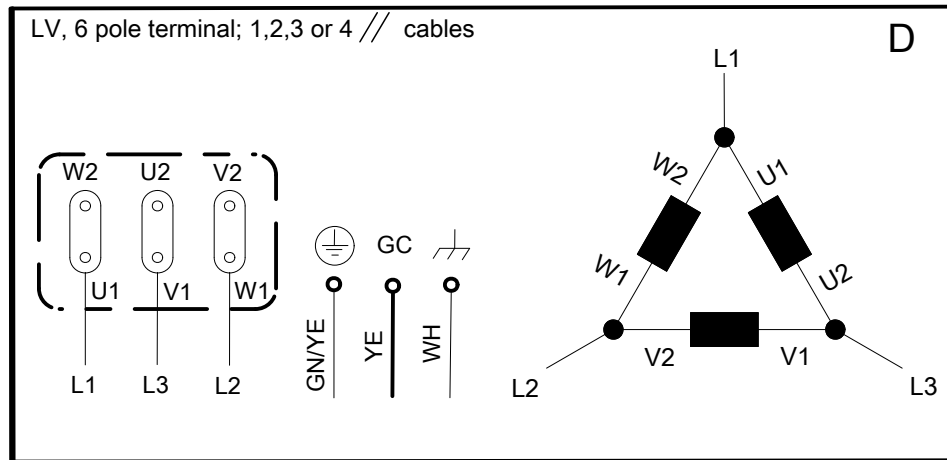

**3-phase connection, screened**

Screened SUBCAB cable without separate ground conductor. The ground conductor is made of stranded ground conductors.

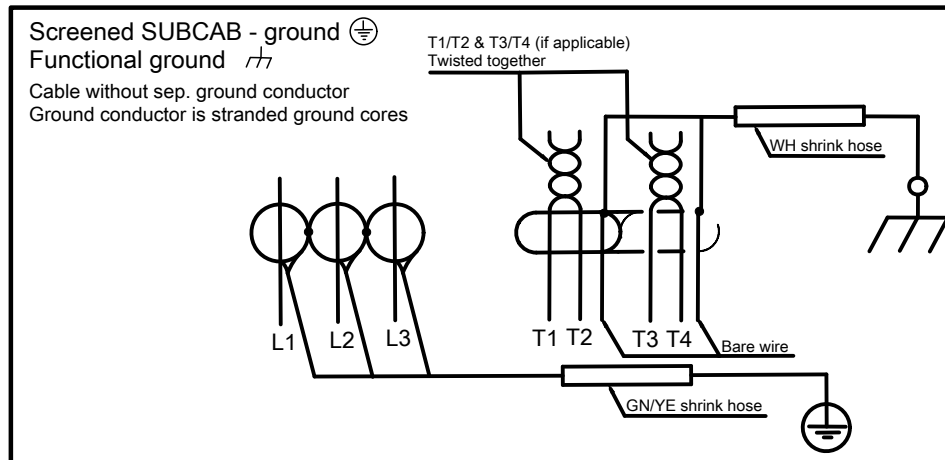

WS004340B

Screened SUBCAB with functional ground. T1 and T2 are twisted together.

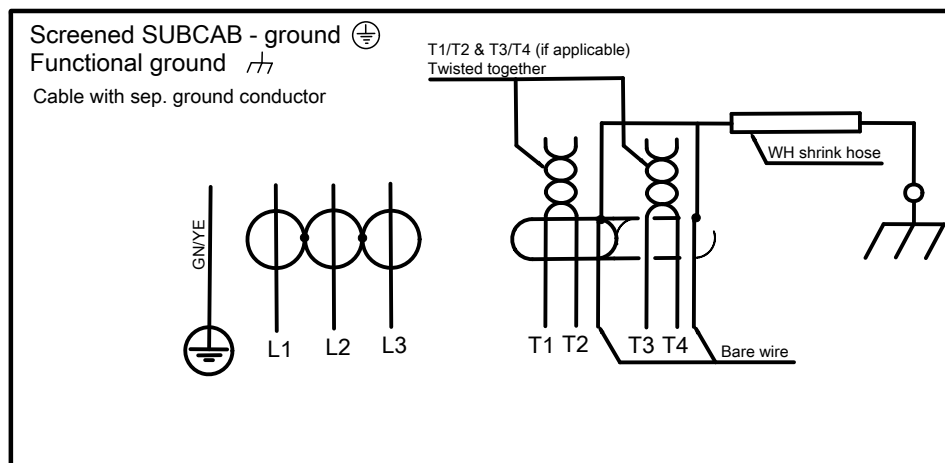

WS004341B



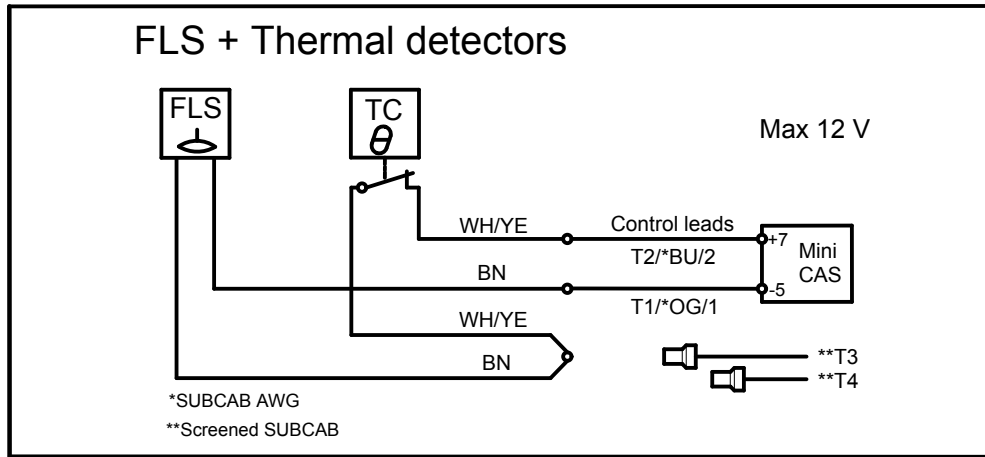

Figure 7: FLS10

Value	Description
$\infty$ ohm	Overtemperature
1200 ohm	OK
430 ohm	Leakage

### Thermistors

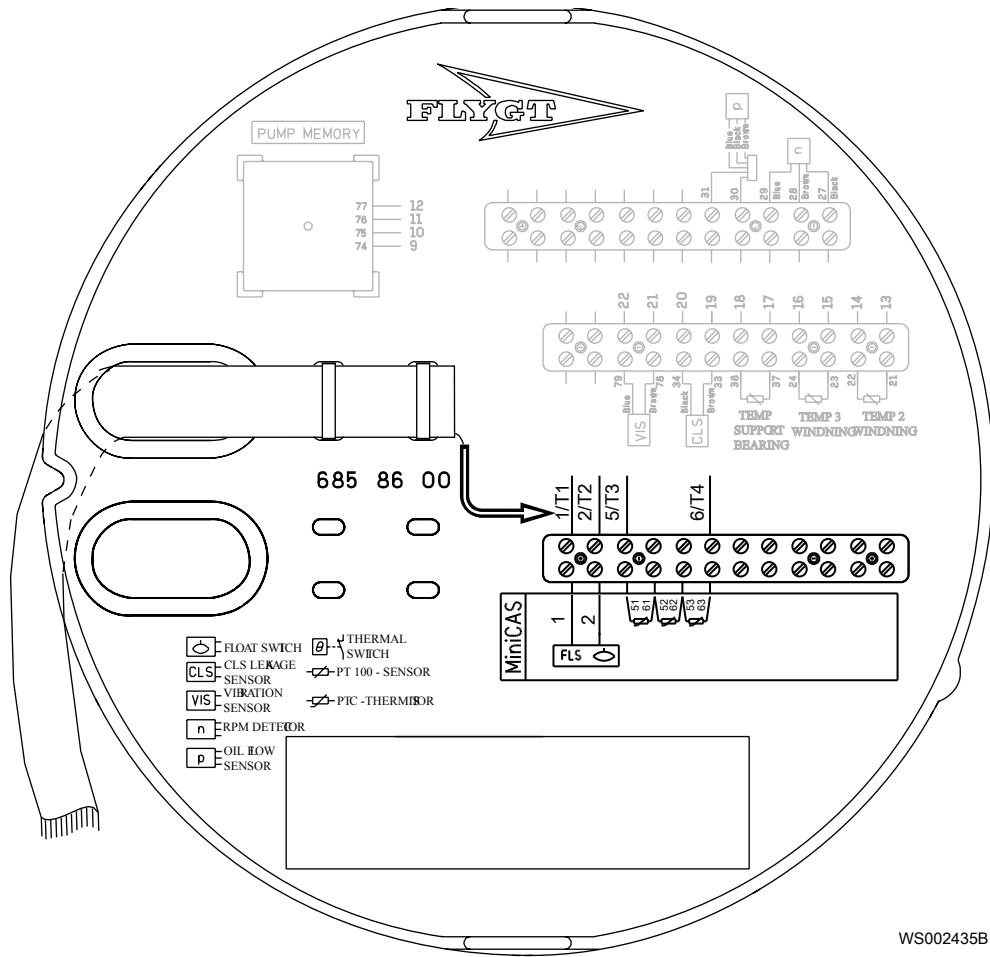

Figure 8: MiniCAS



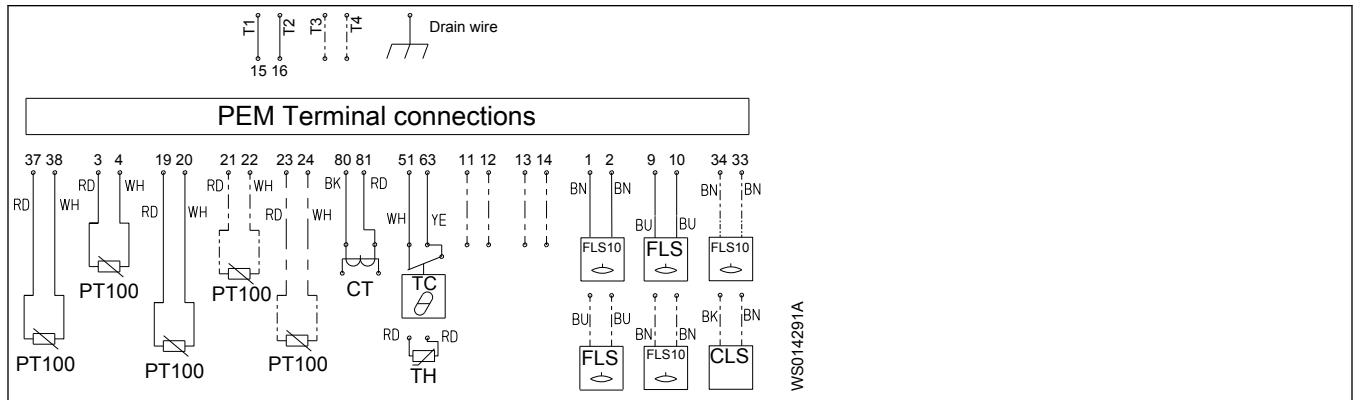

Figure 11: PEM 811 terminal connection overview

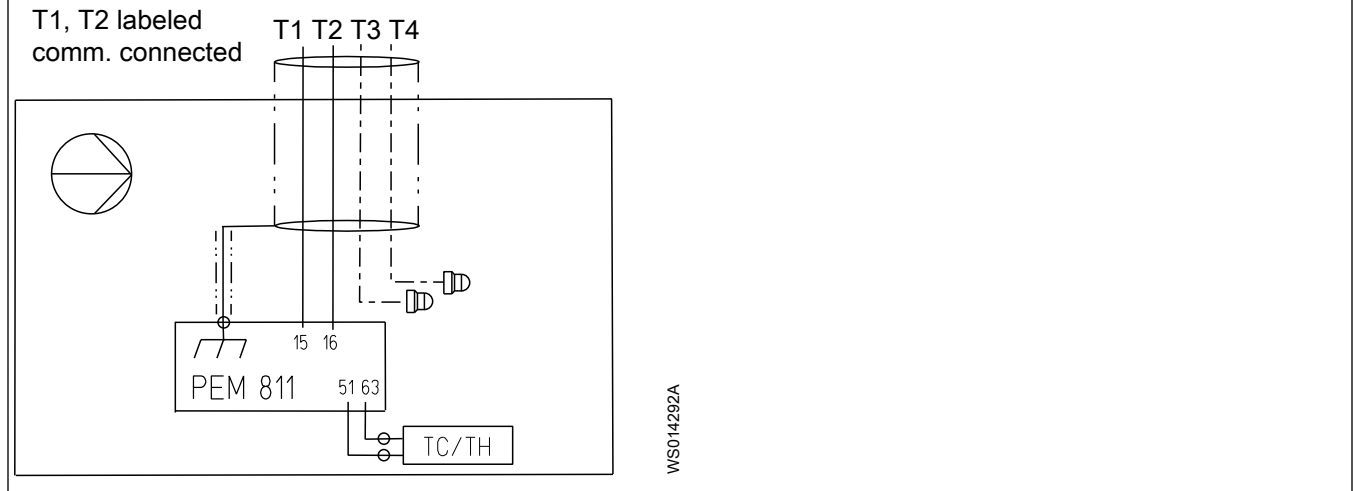

Figure 12: Single cable

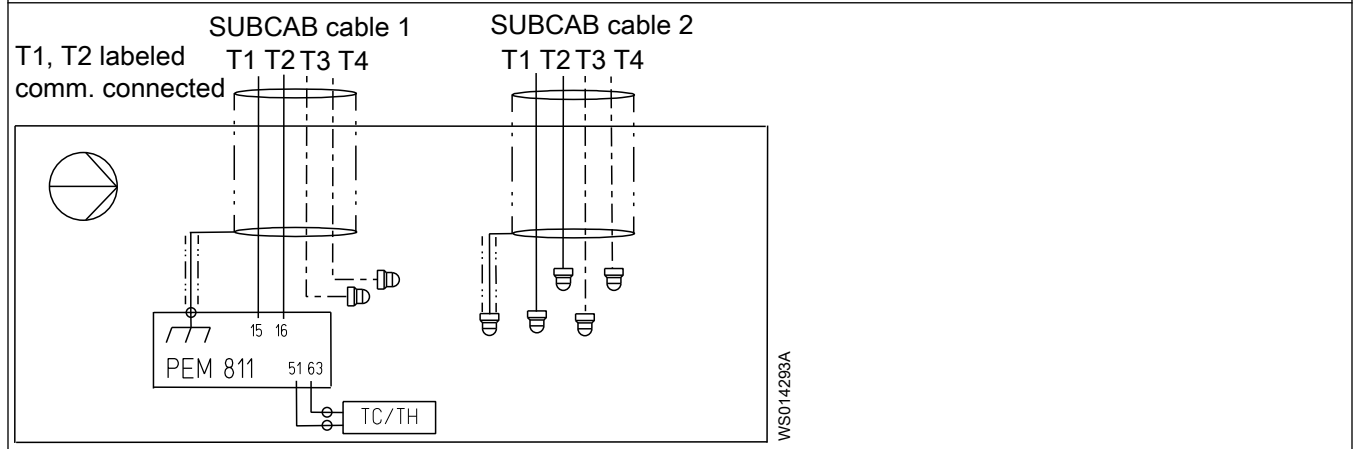

Figure 13: Two cables

Table 2: PEM connections, Ex-proof application

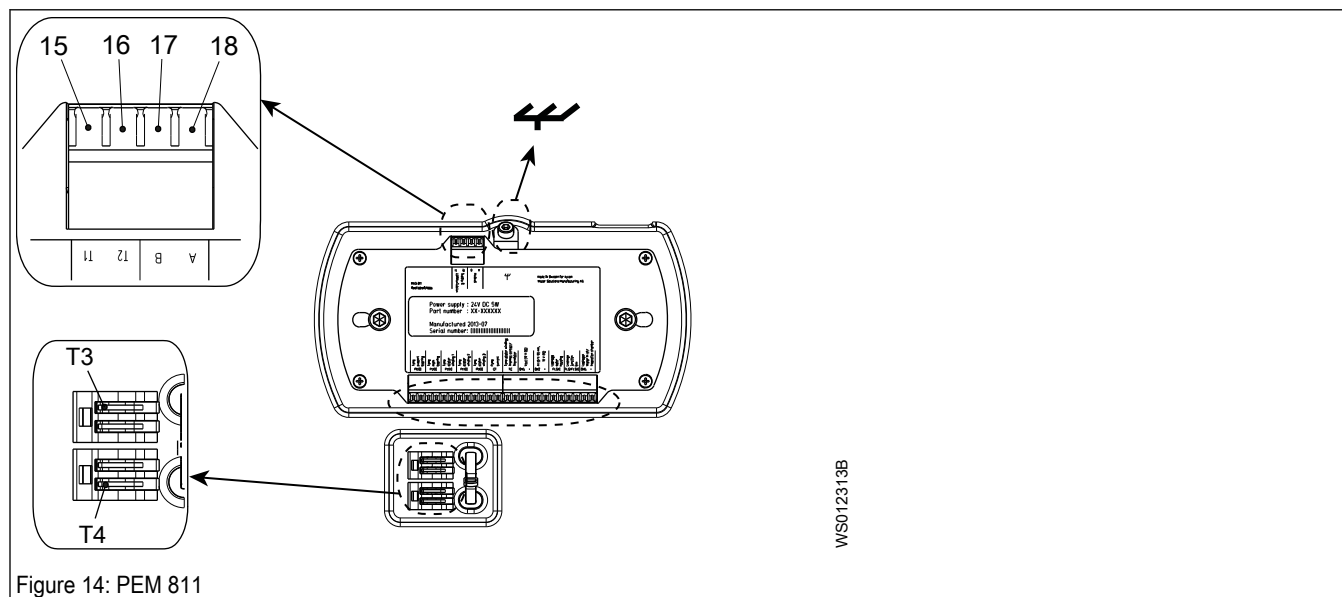

Figure 14: PEM 811

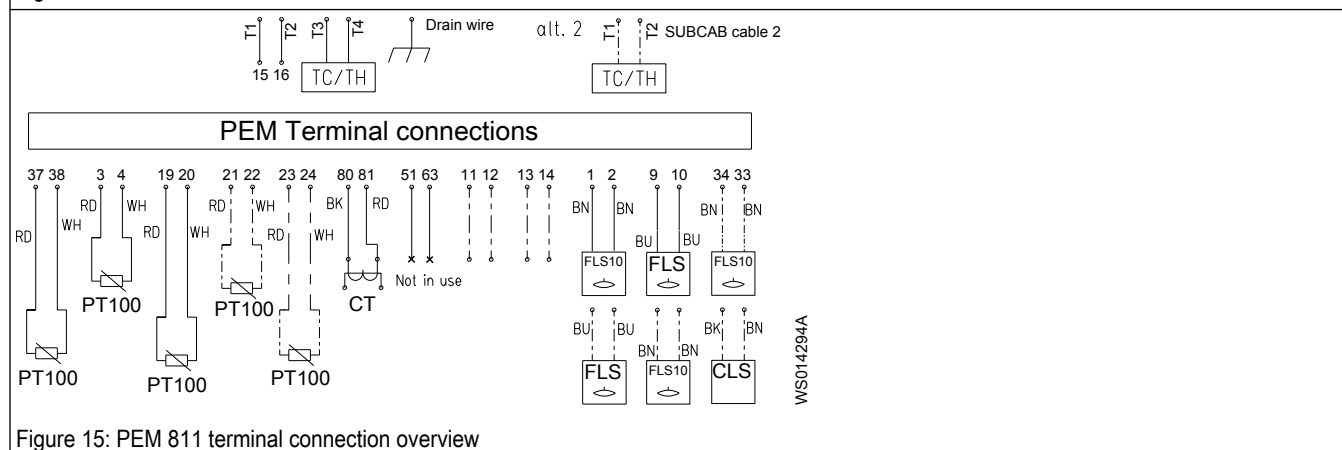

Figure 15: PEM 811 terminal connection overview

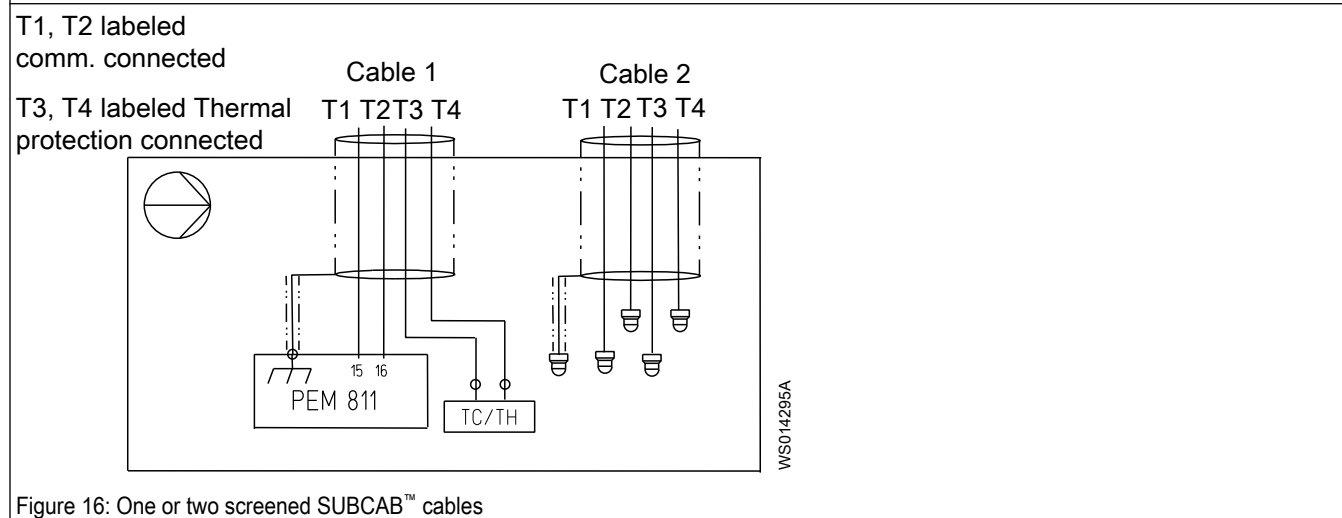

Figure 16: One or two screened SUBCAB™ cables

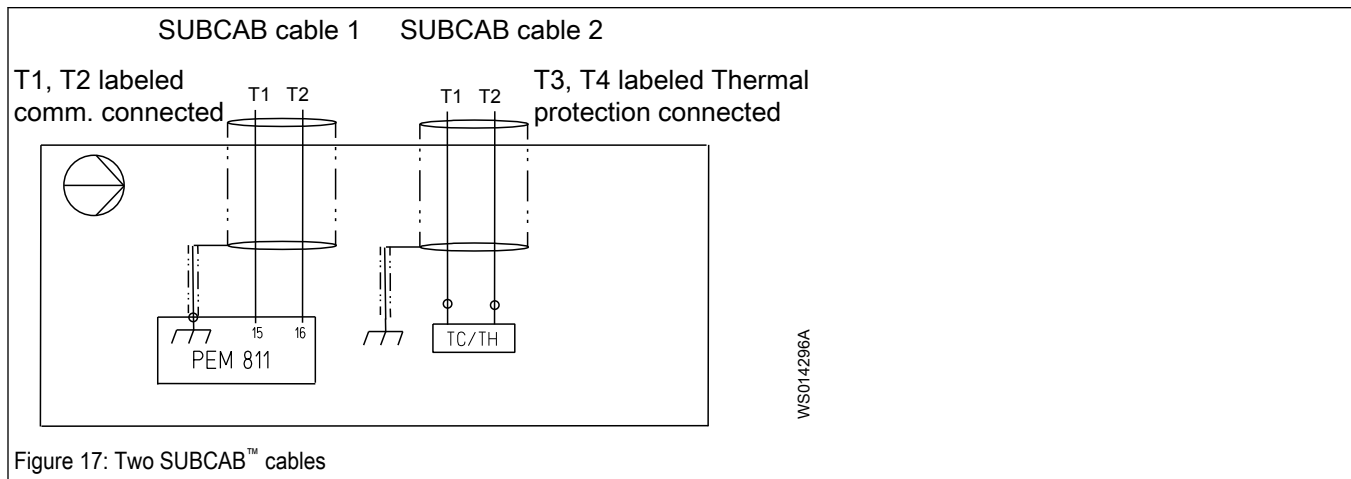
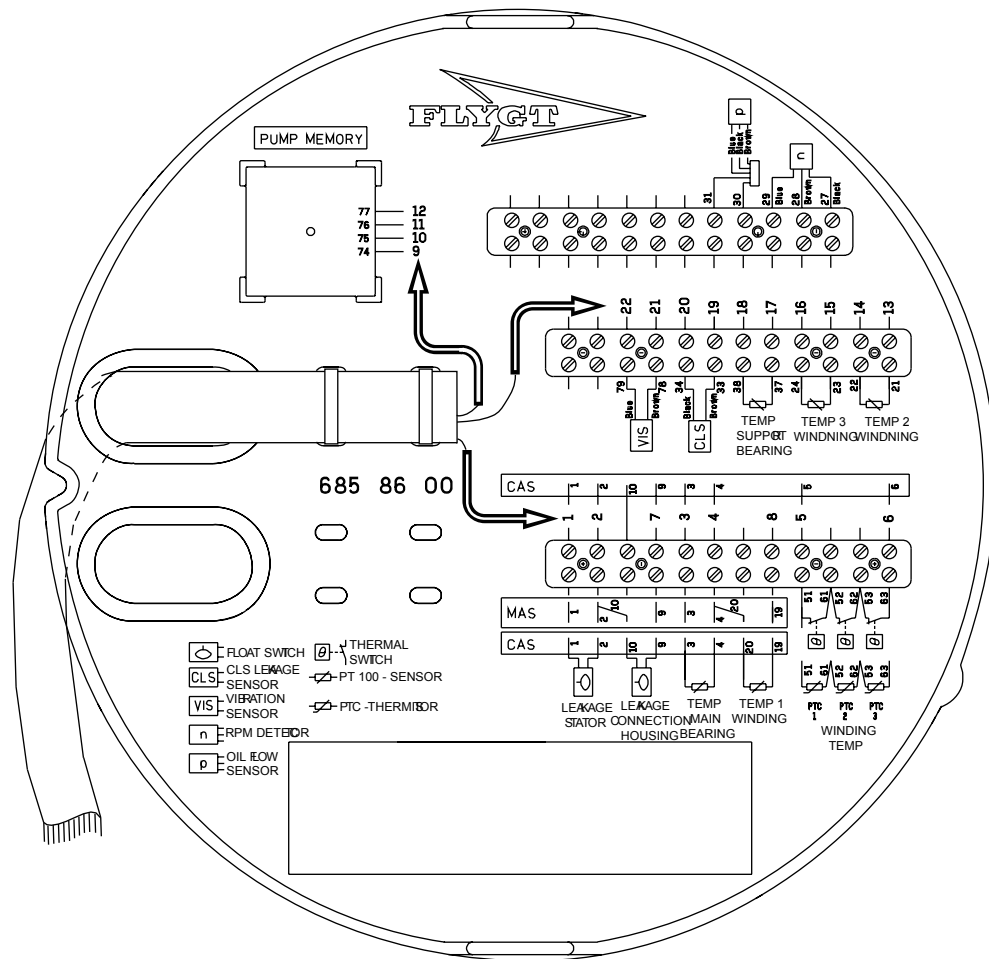

Figure 17: Two SUBCAB™ cables

37, 38	Pt100 temperature sensor Support bearing
3, 4	Pt100 temperature sensor Main bearing
19, 20	Pt100 temperature sensor Stator winding 1
21, 22	Pt100 temperature sensor Stator winding 2
23, 24	Pt100 temperature sensor Stator winding 3
80, 81	CT Pump current
51, 63	Thermal contact or thermistor, TC Stator winding Not used for Ex-pumps
11, 12	V <sub>out</sub> +12 VDC, GND
13, 14	Analog input 0/4–20 mA +12 VDC, GND
1, 2	FLS/FLS10 Leakage, inspection chamber, or stator housing
9, 10	FLS/FLS10 Leakage, junction box
34, 33	FLS10, Leakage, inspection chamber CLS, Water in oil
15	T1 Power supply and communication
16	T2 Power supply and communication
17	B Modbus
18	A Modbus

### 3.6 MAS 711



WS000508A

Figure 18: MAS 711, arrows indicate SUBCAB cable lead numbers

### 3.7 Check the impeller rotation



**CAUTION: Crush Hazard**

The starting jerk can be powerful. Make sure nobody is close to the unit when it is started.

1. Start the motor.
2. Stop the motor after a few seconds.
3. Check that the impeller rotates according to this illustration.

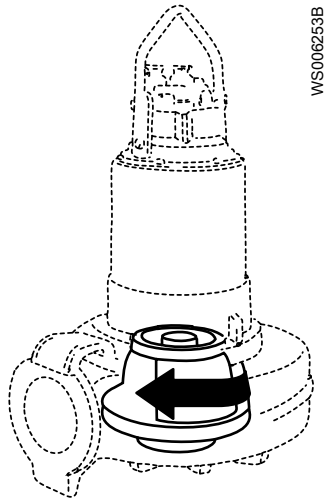

WS006253B

The correct direction of impeller rotation is clockwise when you look at the pump from above.

4. If the impeller rotates in the wrong direction, then transpose two phase leads (3-phase) and do this procedure again.

# 4 Maintenance

## 4.1 Precautions

Before starting work, make sure that the safety instructions have been read and understood.



---

### **DANGER: Crush Hazard**

Moving parts can entangle or crush. Always disconnect and lock out power before servicing to prevent unexpected startup. Failure to do so could result in death or serious injury.



---

### **DANGER: Inhalation Hazard**

Before entering the work area, make sure that the atmosphere contains sufficient oxygen and no toxic gases.



---

### **WARNING: Biological Hazard**

Infection risk. Rinse the unit thoroughly with clean water before working on it.



---

### **CAUTION: Crush Hazard**

Make sure that the unit cannot roll or fall over and injure people or damage property.

Make sure that you follow these requirements:

- Check the explosion risk before you weld or use electrical hand tools.
- Allow all system and pump components to cool before you handle them.
- Make sure that the product and its components have been thoroughly cleaned.
- Before starting work, make sure that the work area is well-ventilated.
- Do not open any vent or drain valves or remove any plugs while the system is pressurized. Make sure that the pump is isolated from the system and that pressure is relieved before you disassemble the pump, remove plugs, or disconnect piping.

## 4.2 Inspect the work area before permit-required hot work



---

### **WARNING: Explosion/Fire Hazard**

Before starting any permit-required hot work such as welding, gas cutting, grinding, or using electrical handtools, do the following: 1. Check the explosion risk. 2. Provide sufficient ventilation.

### **Ground continuity verification**

A ground (earth) continuity test must always be performed after service.

## 4.3 Maintenance guidelines

During the maintenance and before reassembly, always remember to perform these tasks:

- Clean all parts thoroughly, particularly O-ring grooves.
- Change all O-rings, gaskets, and seal washers.
- Lubricate all springs, screws, O-rings with grease.

During the reassembly, always make sure that existing index markings are in line.

The reassembled drive unit must always be insulation-tested and the reassembled pump must always be test-run before normal operation.

## 4.4 Requirements for Ex-approved products

### Basic requirements

- Only authorized personnel are allowed to repair, maintain, and service Ex-approved products.
- Always follow the information about repair, maintenance, and service in the Ex manual while working on an Ex-approved product. For the Ex manual, see the intranet or contact your local Ex Coordinator.
- To ensure that the product complies with the regulations and approval of the authorities, use only original spare parts.
- Always check the dimensions of vital parts before assembly. This requirement applies to spare parts as well.

Failure to meet these requirements may render the Ex-approval invalid.

### Background

In an Ex-approved product the gaps between different parts, for example between the stator housing and the junction box, must be tight enough and long enough to prevent any sparks from the interior of the product from escaping out and igniting surrounding gases. To be able to measure these flameproof gaps accurately, all surfaces that are included in a gap must be clean and free from damages.

The approval drawings show the gaps, in these drawings also called joints, that must be measured and the surfaces that must be inspected for damages. For approval drawings of the product, see the intranet or contact your local Ex Coordinator.

### Documents required

- Approval drawing
- Ex manual
- Report of findings, measurements, tests, and similar, see examples in the Ex manual.

### Temporary storage guidelines

If a disassembled product has to await ordered spare parts, then all parts have to be carefully lubricated and covered. Store all parts separately to ensure that no damage occurs.

## 4.5 The fault-tracing process

### 4.5.1 Trace faults in the drive

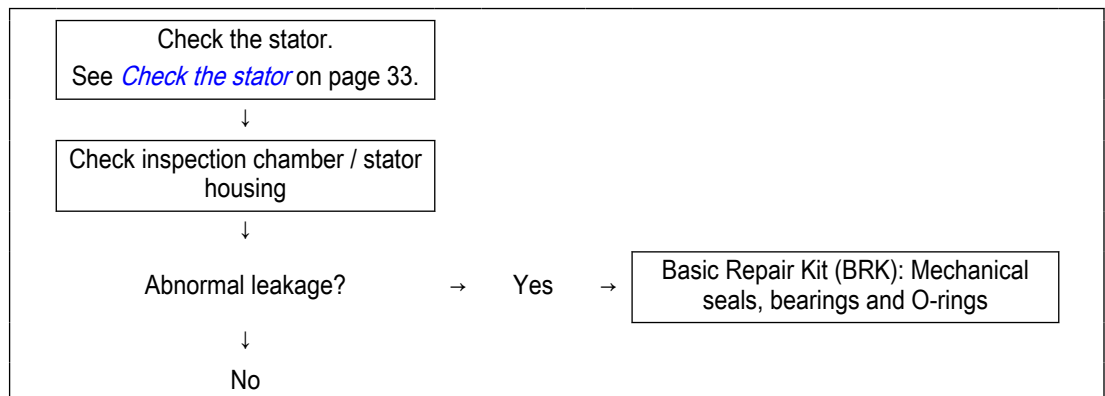

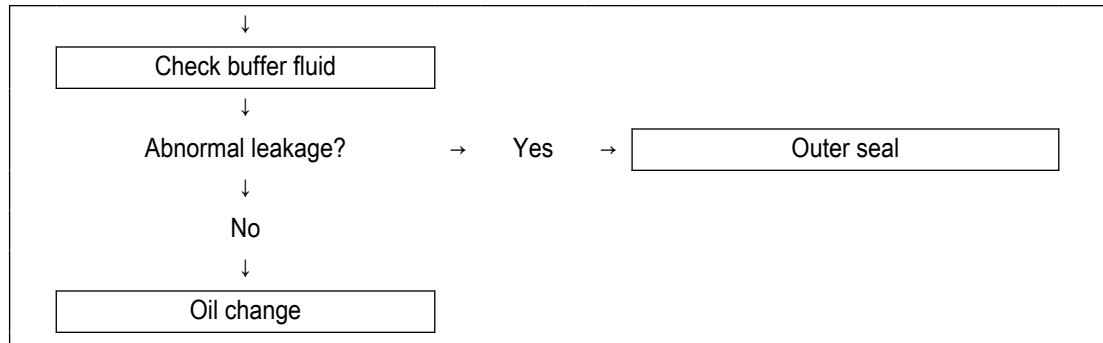

#### 4.5.2 Check the stator

1. Do the 500–1000 VDC insulation test by measuring  $R_1$ ,  $R_2$ ,  $R_3$ ,  $R_4$ ,  $R_5$ , and  $R_6$ .  
 $R_1$  to  $R_6$  are defined in the following table.

Parameter	Measurement
$R_1$	$U_1 - \text{ground}$
$R_2$	$V_1 - \text{ground}$
$R_3$	$W_1 - \text{ground}$
$R_4$	$U_1 - V_1$
$R_5$	$U_1 - W_1$
$R_6$	$V_1 - W_1$

2. With an ohm meter, check that  $R_7$ ,  $R_8$ , and  $R_9$  are reasonably uniform.

Parameter	Measurement
$R_7$	$U_1 - U_2$
$R_8$	$V_1 - V_2$
$R_9$	$W_1 - W_2$

3. Use the following flowchart to determine the action needed.

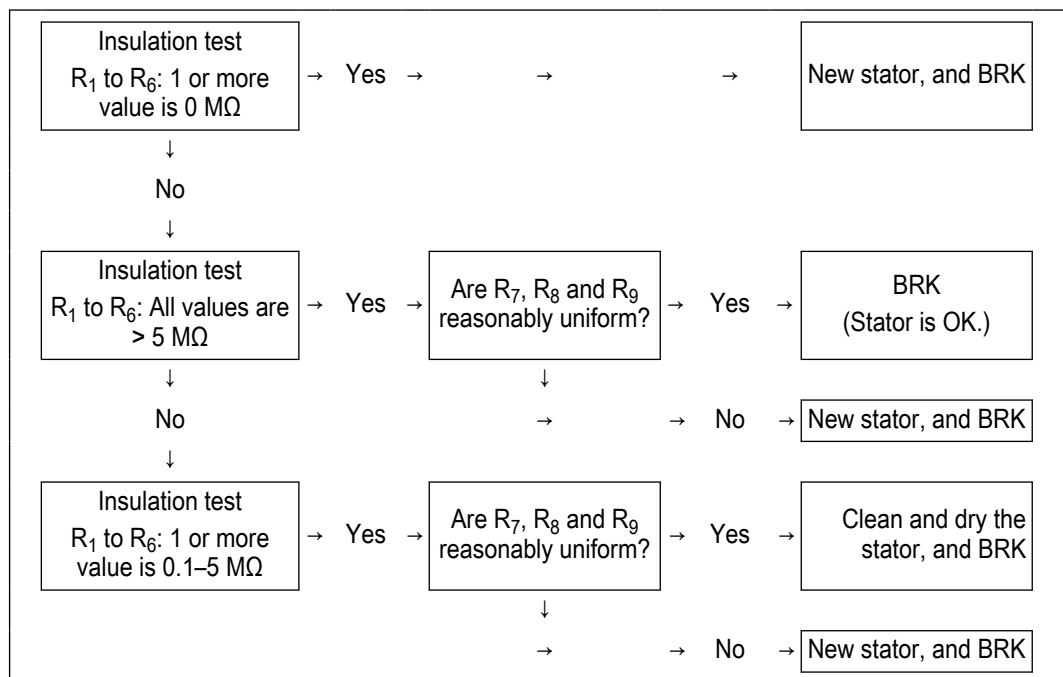

Basic Repair Kit (BRK): Mechanical seals, bearings and O-rings

## 4.6 Service the pump

Type of maintenance	Purpose	Inspection interval
Initial inspection	A Xylem-authorized personnel checks the pump condition. From the results, the personnel recommends the intervals for the periodical inspection and overhaul for the installation.	Within the first year of operation.
Periodical inspection	The inspection prevents operational interruptions and machine breakdowns. The measures to increase performance and pump efficiency are decided for each application. They can include such things as impeller trimming, wear part control and replacement, control of zinc-anodes and control of the stator.	Up to 12,000 hours or three years, whichever comes first. Applies to normal applications and operating conditions at media (liquid) temperatures <40°C (104°F).
Overhaul	The overhaul lengthens the operating lifetime of the product. It includes the replacement of key components and the measures that are taken during an inspection.	Up to 24,000 hours or six years, whichever comes first. Applies to normal applications and operating conditions at media (liquid) temperatures <40°C (104°F).

### NOTICE:

Shorter intervals may be required when the operating conditions are extreme, for example with very abrasive or corrosive applications or when the liquid temperatures exceed 40°C (104°F).

### 4.6.1 Inspection

Service item	Action
Cable	<ol style="list-style-type: none"> <li>1. If the outer jacket is damaged, then replace the cable.</li> <li>2. Check that the cables do not have any sharp bends and are not pinched.</li> </ol>
Connection to power	Check that the connections are properly secured.
Electrical cabinets	Check that they are clean and dry.
Impeller	<ol style="list-style-type: none"> <li>1. Check the impeller clearance.</li> <li>2. Adjust the impeller, if necessary.</li> </ol>
Inspection chamber	<ol style="list-style-type: none"> <li>1. Drain all liquid, if any.</li> <li>2. Check the resistance of the leakage sensor. Normal value approximately 1200 ohms, alarm approximately 430 ohms.</li> <li>3. Check the resistance of the leakage sensor. If the pump is connected to the MAS 801 or MAS 711, then it is recommended that the sensors be checked in the MAS unit. Otherwise, use a multimeter. For values, see <a href="#">Connection to the pump</a>. Make sure to select values for the appropriate monitoring equipment and sensor combination.</li> </ol>
Insulation	<p>Use a megger maximum 1000 V.</p> <ol style="list-style-type: none"> <li>1. Check that the resistance between the ground (earth) and phase lead is more than 5 megohms.</li> <li>2. Conduct a phase-to-phase resistance check.</li> </ol>

Service item	Action
Junction box	<ol style="list-style-type: none"> <li>1. Check that it is clean and dry.</li> <li>2. Check the resistance of the leakage sensor. If the pump is connected to the MAS 801 or MAS 711, then it is recommended that the sensors be checked in the MAS unit. Otherwise, use a multimeter. Normal value approximately 1530 ohms, alarm approximately 330 ohms.</li> </ol>
Level regulators	Check the condition and functionality.
Lifting device	Check that the local safety regulations are followed.
Lifting handle	<ol style="list-style-type: none"> <li>1. Check the screws.</li> <li>2. Check the condition of the lifting handle and the chain.</li> <li>3. If necessary, replace.</li> </ol>
O-rings	<ol style="list-style-type: none"> <li>1. Replace the oil plug O-rings.</li> <li>2. Replace the O-rings at the entrance or junction cover.</li> <li>3. Grease the new O-rings.</li> </ol>
Overload protection and other protections	Check the correct settings.
Personnel safety devices	Check the guard rails, covers, and other protections.
Rotation direction	Check the impeller rotation.
Seal housing	<ol style="list-style-type: none"> <li>1. Fill with new coolant, if necessary. Applicable for Ex-version.</li> <li>2. Check that the freezing point is lower than -13°C (9°F).</li> </ol>
Terminal board	Check that the connections are properly secured.
Temperature sensors: – Thermal contact – Thermistor – Pt100	<p>If the pump is connected to the MAS 801 or MAS 711, then it is recommended that the sensors be checked in the MAS unit. Otherwise, use a multimeter.</p> <p>Do not use a device applying a higher voltage than 2.5 V.</p> <ol style="list-style-type: none"> <li>1. Disconnect the sensor leads.</li> <li>2. Measure the resistance to check the status of the sensor and leads according to values in <a href="#">Make the electrical connections</a> on page 11. Make sure to select values for the appropriate sensor, monitoring equipment, and sensor combination.</li> <li>3. Measure between each sensor lead to ground (earth) to establish that the resistance is infinite (or at least several Megaohm).</li> </ol>
Voltage and amperage	Check the running values.

#### 4.6.2 Overhaul

The basic repair kit includes O-rings, seals, and bearings.

For an overhaul, do the following in addition to the tasks listed under Inspection.

Service item	Action
Support and main bearing	Replace the bearings with new bearings.
Mechanical seal	Replace with new seal units.

#### 4.6.3 Service in case of alarm

For information about indication values for sensors, see [Make the electrical connections](#) on page 11.

Alarm source	Action
FLS	<ol style="list-style-type: none"> <li>1. Check for liquid in the connection housing.</li> <li>2. Drain all liquid, if any.</li> <li>3. Check the O-rings and the cable entry, if liquid was found.</li> </ol>

Alarm source	Action
FLS10	<ol style="list-style-type: none"> <li>1. Drain the fluid in the inspection chamber.</li> <li>2. Check the coolant level. Fill with new coolant if necessary.</li> <li>3. Check the freezing point (lower than -13°C or 9°F).</li> </ol> <p>Check the inspection chamber again after one week of operation. If leakage has occurred, then do the following:</p> <ol style="list-style-type: none"> <li>1. Drain the fluid.</li> <li>2. Change the mechanical seal unit.</li> <li>3. Replace with new coolant.</li> </ol>
The thermistor/Thermal contact	<ol style="list-style-type: none"> <li>1. Check the coolant level (pump with cooling jacket).</li> <li>2. Check the start and stop levels.</li> </ol>
The overload protection	Check that the impeller can rotate freely.

## 4.7 Change the coolant

This image shows the plugs that are used to change the coolant.

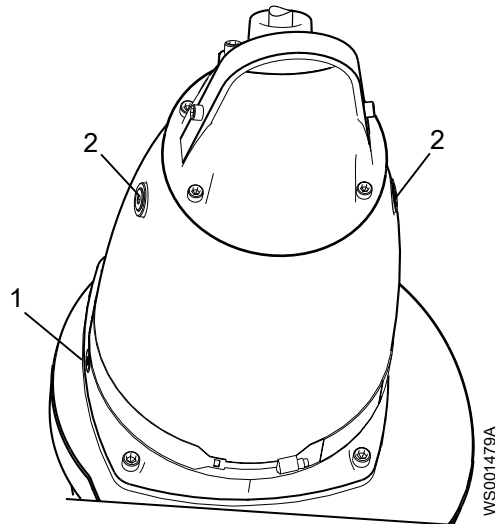

Figure 19: With a cooling jacket

1. Inspection plug
2. Coolant plugs

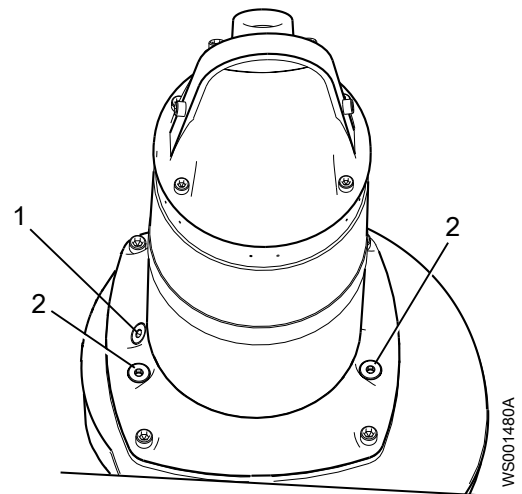

Figure 20: Without a cooling jacket

### 4.7.1 Empty the coolant



#### **CAUTION: Compressed Gas Hazard**

Air inside the chamber may cause parts or liquid to be propelled with force. Be careful when opening. Allow the chamber to de-pressurize before removal of the plug.

1. Empty the coolant in the inspection chamber:
  - a) Remove the inspection plug.

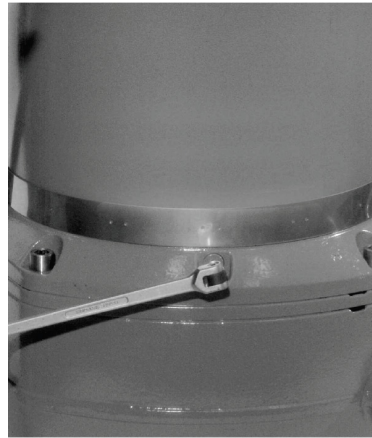

WS0002122B

Figure 21: With a cooling jacket

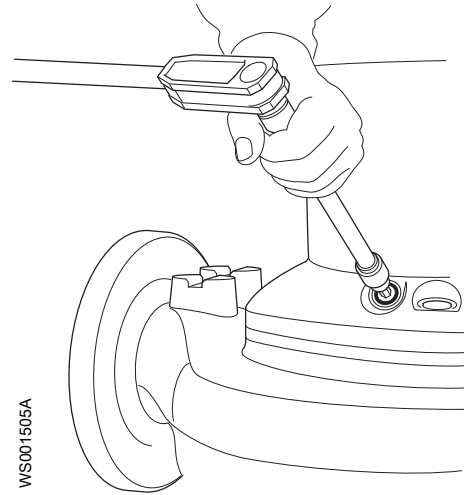

WS001505A

Figure 22: Without a cooling jacket

- b) Pump out any coolant from the inspection chamber, as shown here.

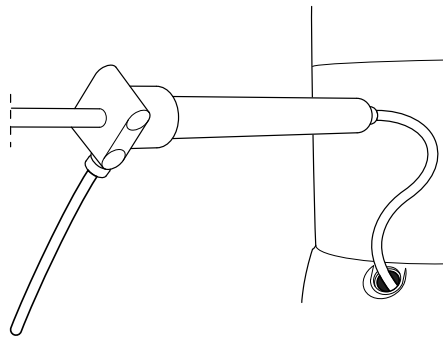

WS0009196B

Figure 23: With a cooling jacket

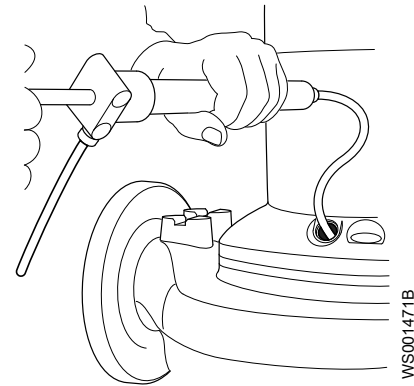

WS001471B

Figure 24: Without a cooling jacket

- c) Fit a new O-ring and reinstall the inspection plug. Tighten the plug.  
Tightening torque: 44 Nm (33 lbf-ft)
2. To empty the coolant with the pump upright, do the following:  
This method is applicable only for pumps without cooling jackets.
- a) Remove the coolant plugs.





---

**CAUTION: Compressed Gas Hazard**

Air inside the chamber may cause parts or liquid to be propelled with force. Be careful when opening. Allow the chamber to de-pressurize before removal of the plug.

---

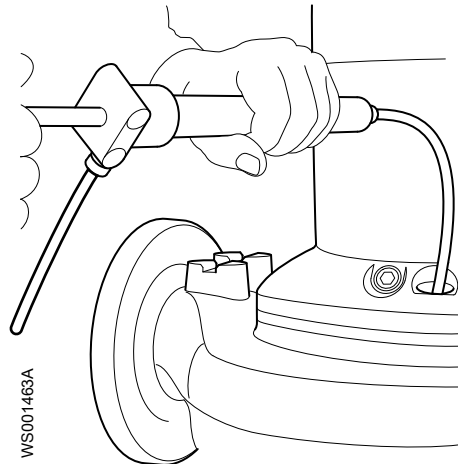
- b) Use a pump to remove the coolant.



3. If it is necessary to separate the drive unit from the hydraulic unit, then do the following:
  - a) Carefully open the coolant plugs to release any built-up pressure inside the cooling jacket.



---

**CAUTION: Compressed Gas Hazard**

Air inside the chamber may cause parts or liquid to be propelled with force. Be careful when opening. Allow the chamber to de-pressurize before removal of the plug.

---

- b) After releasing any built-up pressure in the cooling jacket, reinstall the coolant plugs.
  - c) Remove the pump housing screws.
  - d) Remove the drive unit from the pump housing.

---

**NOTICE:**

Do not allow the weight of the pump to rest on any portion of the impeller. The impeller must not be allowed to make contact with the concrete floor or other hard or rough surfaces.

---

4. To empty the coolant by using the pump in a horizontal position, do the following:
  - a) Put the pump horizontally, so that one of the coolant plugs is at the lowest point of the pump.  
It is important that the coolant drains completely.
  - b) Put a container under the pump.
  - c) Remove the coolant plugs and empty the coolant.

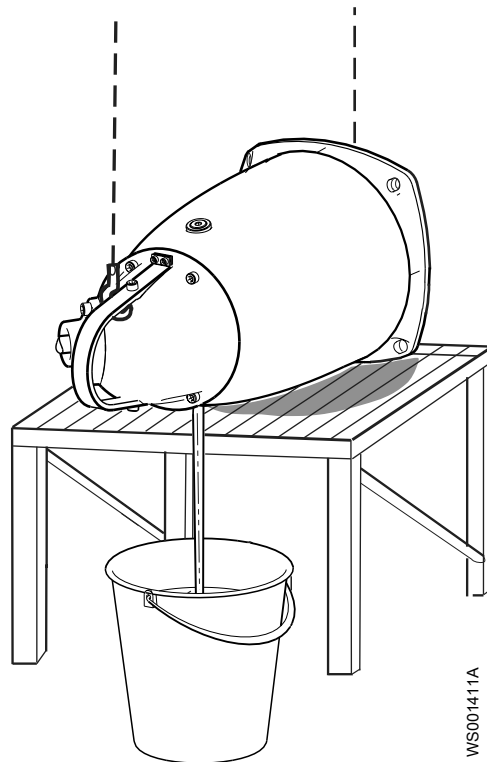

Figure 25: With a cooling jacket

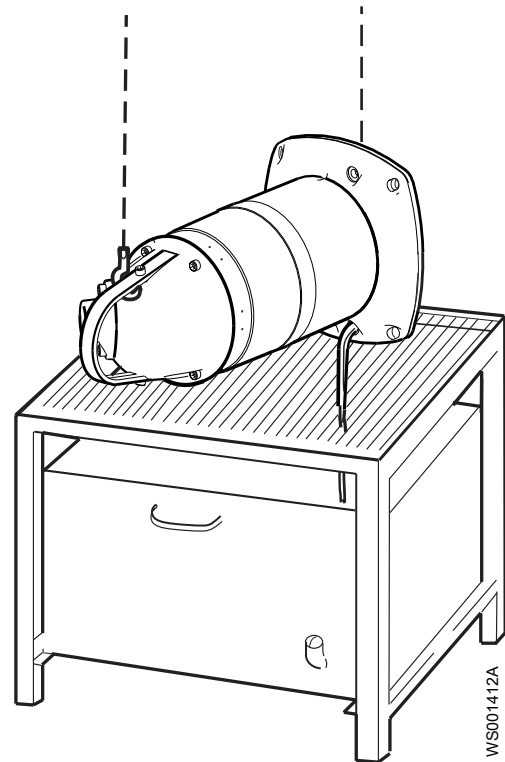

Figure 26: Without a cooling jacket

#### 4.7.2 Fill with coolant

Use a coolant that is a mixture of 70% deionized or distilled water, and 30% DOWCAL 200E monopropylene glycol. If DOWCAL 200E from Dow Chemical Company is not available, then contact your local Xylem representative. The monopropylene glycol must fulfill the Xylem material standard M0800.82.0002.

#### NOTICE:

Deionized or distilled water must be used in the water-glycol mixture.

If the pumped liquid includes potable water or substances to be ingested, then contact a sales or authorized service representative.

1. Fill with coolant until it overflows through the opposite hole, as shown here.

Pump	Quantity, L (qt.)	
	With cooling jacket	Without cooling jacket
3315	55 (58.1)	9.5 (10.0)

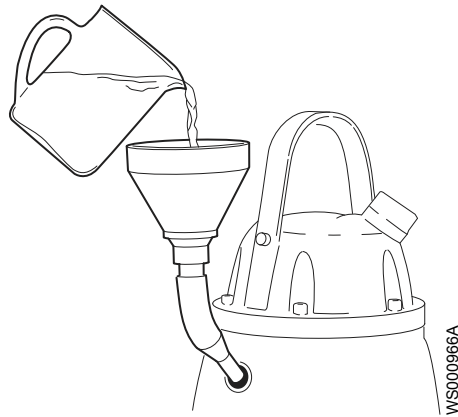

Figure 27: With cooling jacket

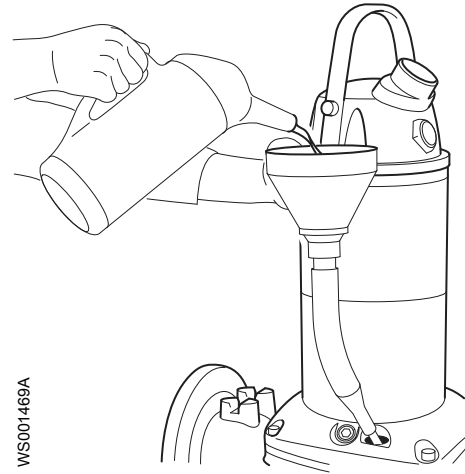

Figure 28: Without cooling jacket

2. Fit new O-rings and reinstall the coolant plugs. Tighten the plugs.  
Tightening torque: 44 Nm (33 lbf·ft)

## 4.8 Disassemble the pump

Before the pump is disassembled the pump has to be drained of all coolant. For information, see [Empty the coolant](#) on page 36.

### 4.8.1 Remove the connection housing

1. Remove the cover screws and the cover.

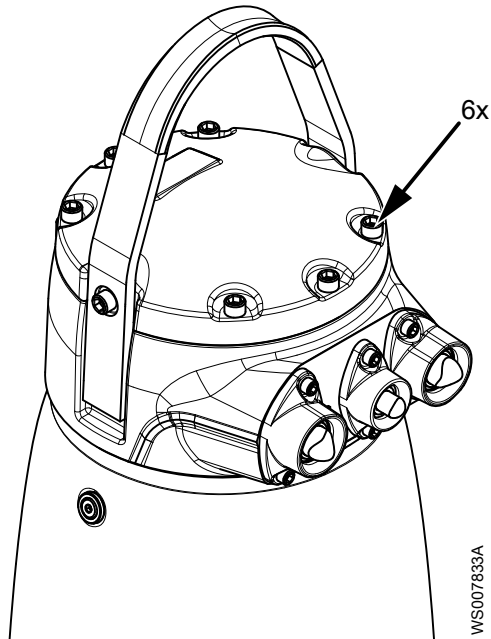

2. Disconnect the sensor leads from the terminal board on the terminal plate. See [Make the electrical connections](#) on page 11.

It is not necessary to disconnect the monitoring cable from the terminal board.

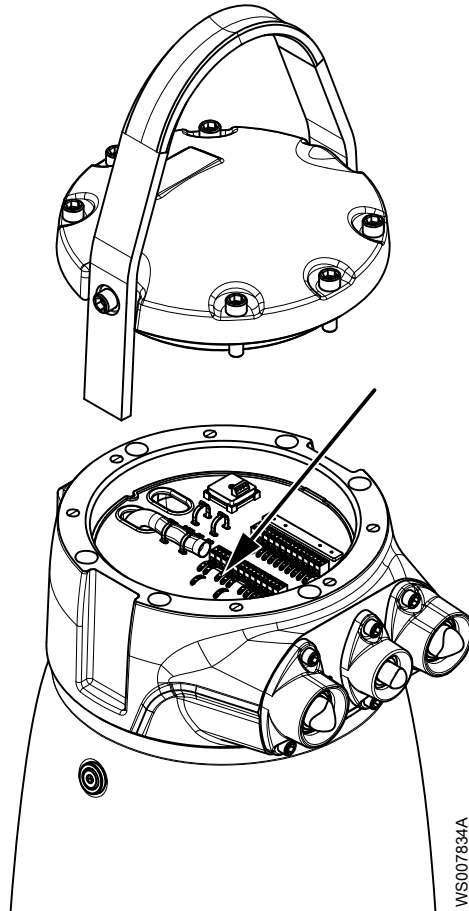

3. Turn the terminal plate away from the connection housing as far as the slack of the monitoring cable allows.

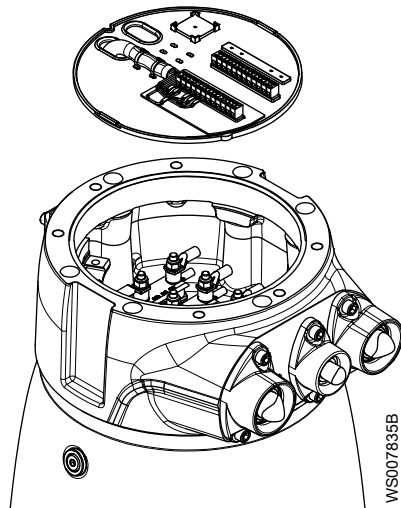

4. Disconnect the motor cable leads. See [Make the electrical connections](#) on page 11

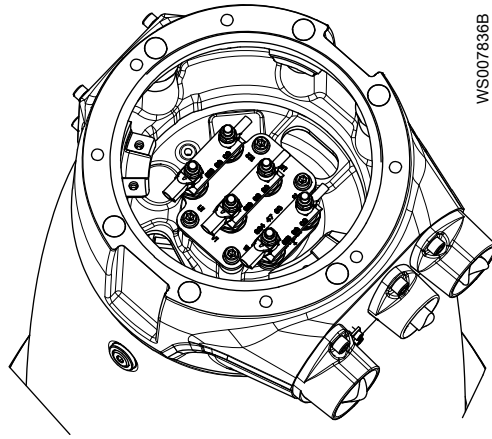

5. Remove the connection housing screws. Remove the connection housing together with the terminal plate and the cables.

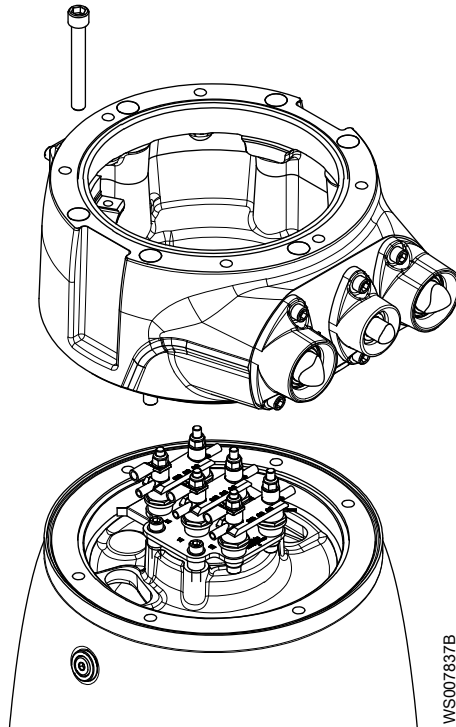

#### 4.8.2 Remove the cooling jacket

1. Remove the outer cooling jacket:
  - a) Remove the coolant filling plugs.
  - b) Screw two M16 screws into the coolant filler holes of the cooling jacket.  
The screws needs to be about 50 mm (2 in.) long.

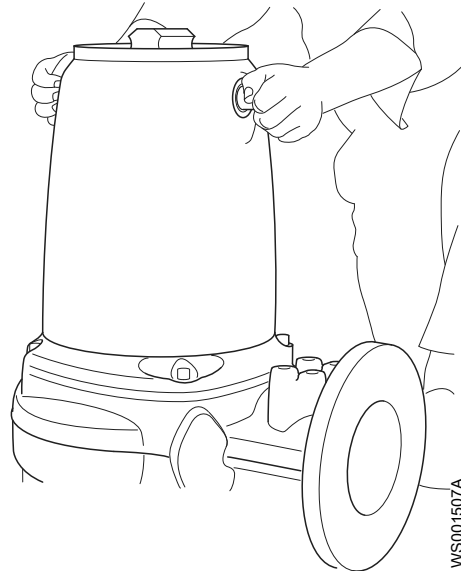

c) Lift off the outer cooling jacket.



2. Remove the inner cooling jacket:

a) Remove the screws and washers or the four wire bows that hold the inner cooling jacket in place.

If the cooling jacket is mounted with wire bows, use a screwdriver to bend them loose.

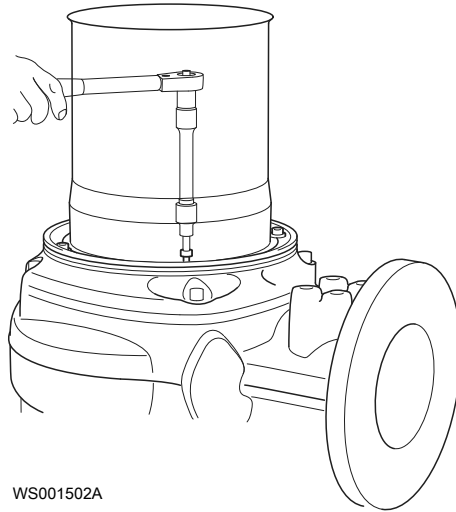
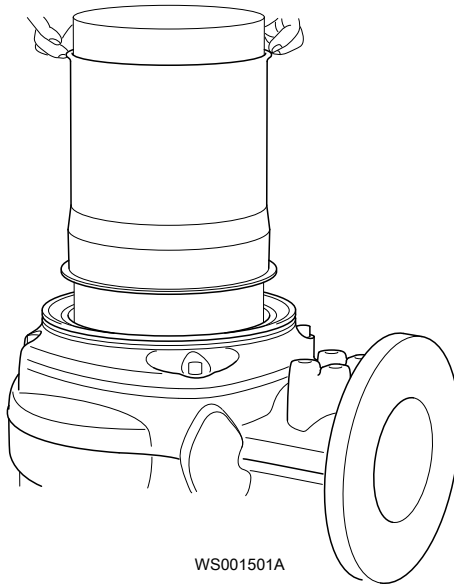

Figure 29: Mounted with screws



Figure 30: Mounted with wire bows

b) Lift off the inner cooling jacket.



### 4.8.3 Remove the impeller

Required tools

- 14 mm hexagon bit adapter (allen socket) with at least a 100 mm (4 in.) extension
- Rod (wood or plastic) for locking the impeller in place.
- Trim tool (24 mm hexagon bar, 300 mm long)



---

**CAUTION: Cutting Hazard**

Worn parts can have sharp edges. Wear protective clothing.

---

**NOTICE:**

When laying the pump on its side, do not allow the weight of the pump to rest on any portion of the impeller. The impeller must not be allowed to make contact with the concrete floor or other hard and rough surfaces.

---

**NOTICE:**

If you fail with the impeller installation, you must redo the installation procedure from the beginning.

## 4.8.4 Remove the impeller: wet installation

**CAUTION: Cutting Hazard**

Sharp edges. Wear protective clothing.

1. Place the pump in a horizontal position.
2. Loosen the impeller:
  - a) Lock the impeller in place by inserting a rod through the pump housing outlet.
  - b) Remove the cover screw and the cover.
  - c) Remove the screw unit.

For instructions about how to remove the screw unit, see [Handle the screw unit](#) on page 50.

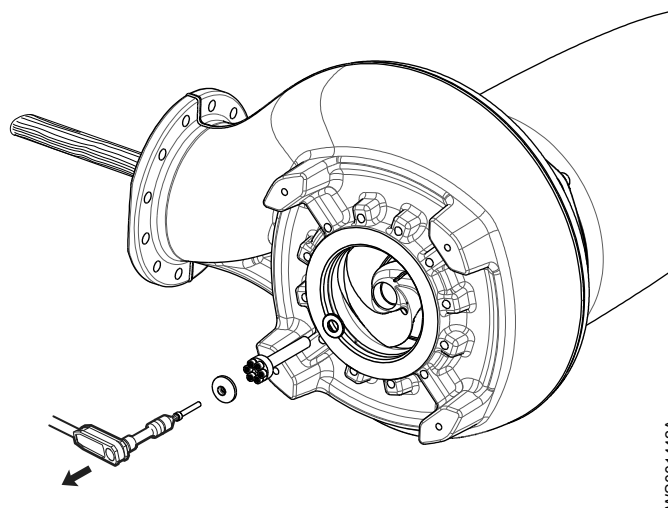

- d) Turn the adjustment screw counterclockwise until the impeller breaks free from the shaft.

Use the trim tool.

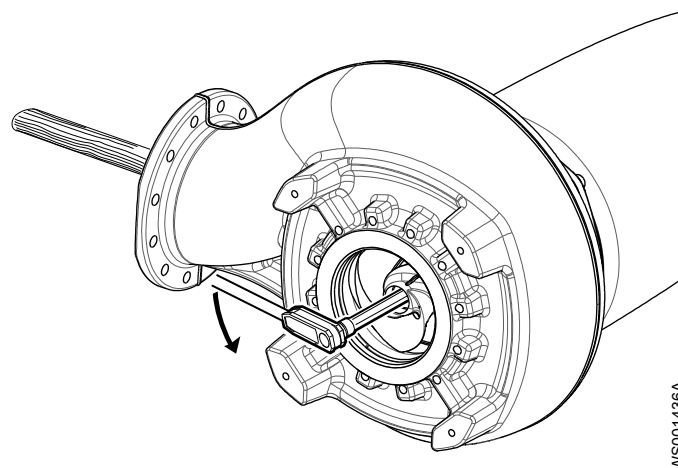

- e) Hand-tighten the center screw to prevent the impeller from falling off.
- f) Remove the rod.

3. Raise the pump.
4. Remove the drive unit from the pump housing:
  - a) Remove the pump housing screws.

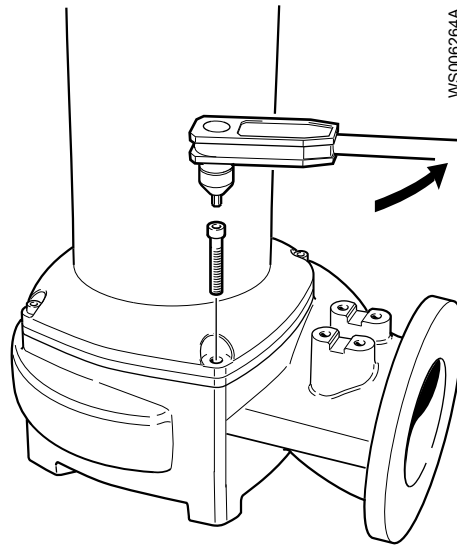

- b) Remove the drive unit from the pump housing.

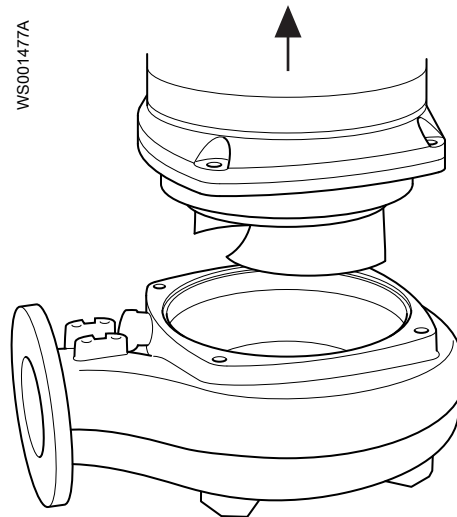

5. Remove the impeller:
  - a) Fit M12 lifting eyebolts into two of the holes for the pump housing screws and place the drive unit in a horizontal position.

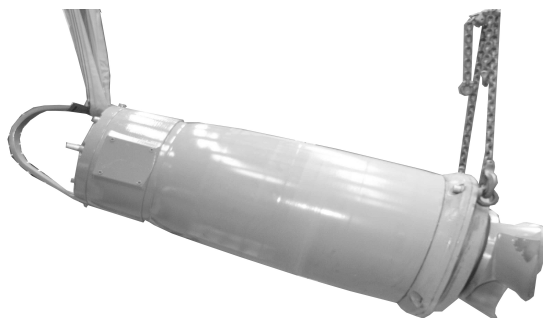

WS002109A

- b) Prevent the impeller from falling off by attaching a round sling. Protect the round sling from the trailing edges of the impeller.



WS002110A

- c) Remove the screw unit.  
For instructions about how to remove the screw unit, see [Handle the screw unit](#) on page 50.
- d) Remove the impeller and the conical sleeve.

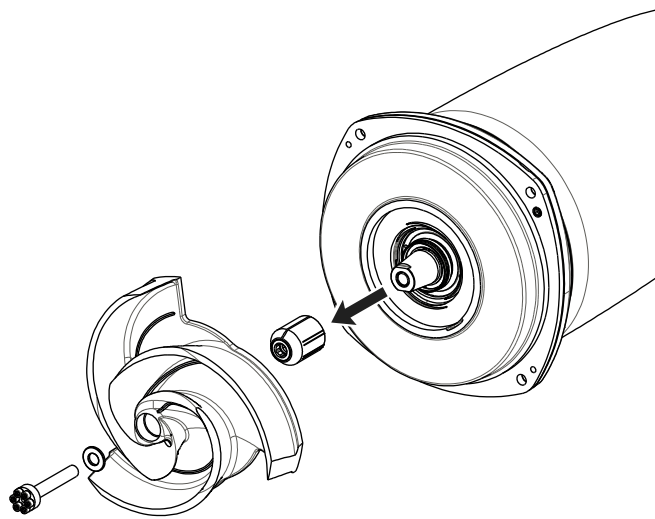

WS001444A

#### 4.8.5 Remove the impeller: dry installation



---

**CAUTION: Cutting Hazard**

Sharp edges. Wear protective clothing.

---

1. Remove the drive unit from the pump housing:
  - a) Remove the pump housing screws.

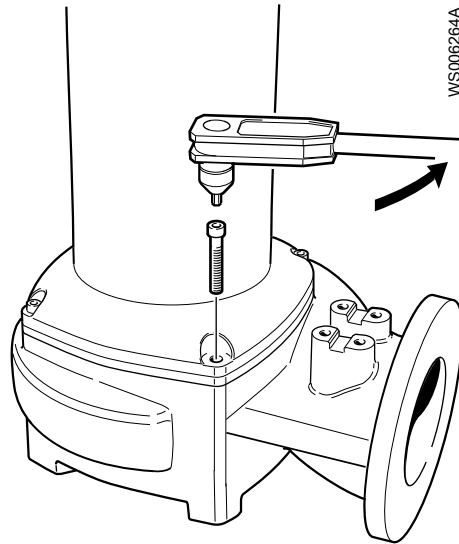

b) Remove the drive unit from the pump housing.

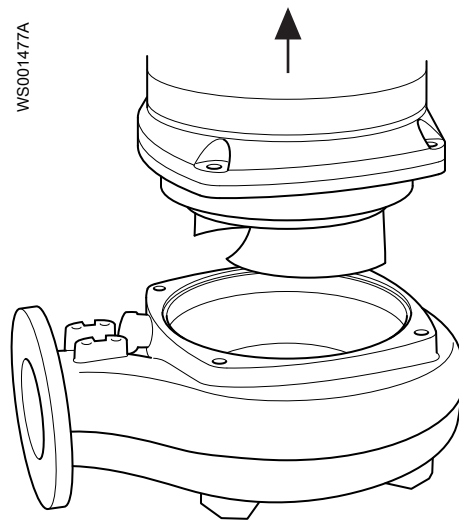

2. Remove the impeller:

a) Fit M12 lifting eyebolts into two of the holes for the pump housing screws and place the drive unit in a horizontal position.

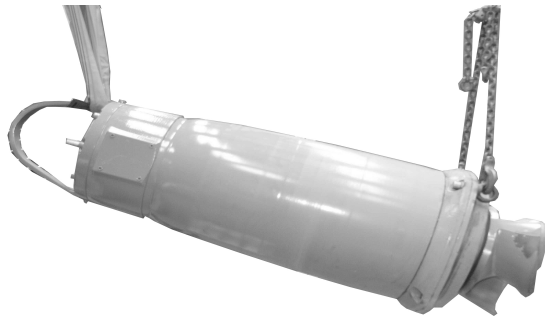

WS002109A

b) Lock the impeller as shown in the figure.



WS002111A

- c) Remove the cover screw and the cover.
- d) Remove the screw unit.  
For instructions about how to remove the screw unit, see [Handle the screw unit](#) on page 50.
- e) Remove the board that locks the impeller.
- f) Prevent the impeller from falling off by attaching a round sling.  
Protect the round sling from the trailing edges of the impeller.



WS002110A

- g) Turn the adjustment screw counterclockwise until the impeller breaks free from the shaft.  
Use the trim tool.
- h) Remove the impeller and the conical sleeve.

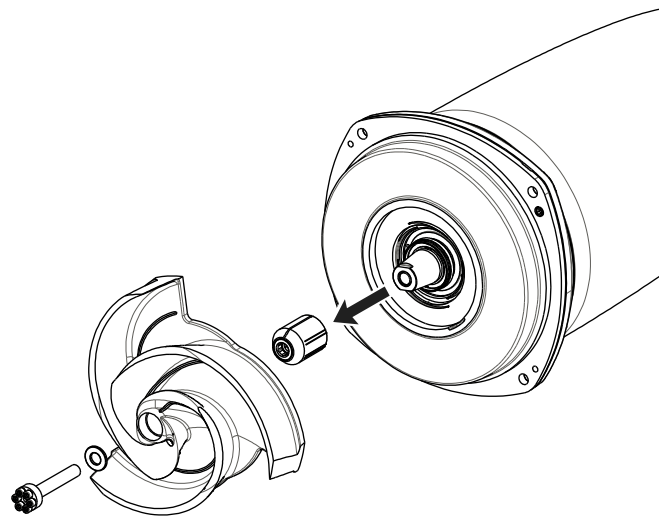

#### 4.8.6 Handle the screw unit

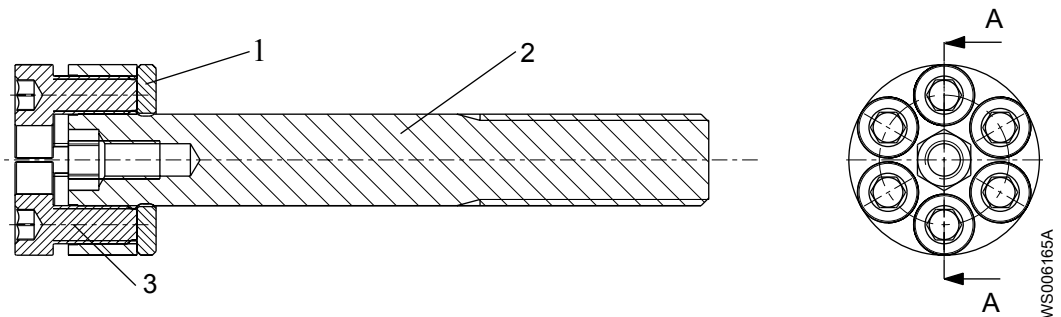

1. Washer
2. Center screw
3. Peripheral screws

**NOTICE:**

Avoid breaking the threads of the screws. Always make sure that the screws in the unit are removed or installed according to this procedure.

1. Remove the screw unit.
  - a) Loosen the peripheral screws in a star pattern.  
Each peripheral screw must, in every step, first be loosened and then fitted by hand until it touches the washer again.

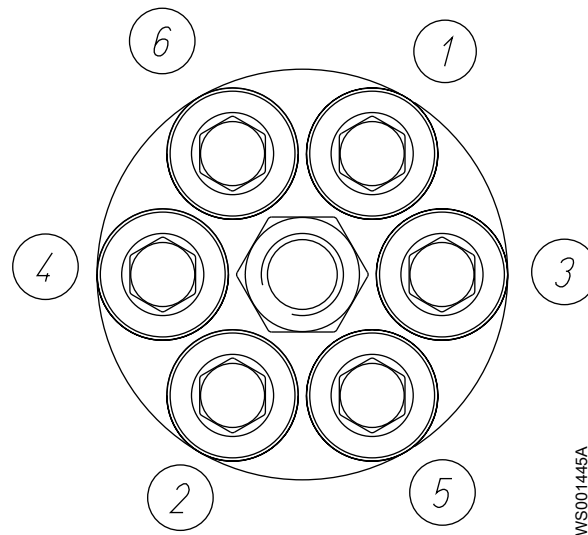

Figure 31: Star pattern for peripheral screws

- b) Repeat this procedure until there is no more load on the peripheral screws. Three or four repetitions are normally enough.
  - c) Remove the center screw.
2. Fit the screw unit.
- a) Make sure that all contact surfaces and threads are clean.
  - b) Lubricate all contact surfaces and threads with grease.
  - c) Unscrew the peripheral screws so they do not touch the washer.
  - d) Fit the screw unit to the shaft.
  - e) Tighten the center screw.  
Tightening torque: 100 Nm (74 ft-lb)
  - f) Tighten the peripheral screws in a star pattern.
- Repeat this procedure until the load is evenly distributed. Use the torque values in the following table.

Repetition	Tightening torque
1	12 Nm (8.9 ft-lb)
The following repetitions	24 Nm (18 ft-lb)

Three or four repetitions are normally enough.

#### 4.8.7 Remove the insert ring

Remove the insert ring:

- a) Remove the insert ring plugs and screws.
- b) Lift off the insert ring from the pump housing.

If the insert ring is stuck, then turn the pump housing upside-down and use a screwdriver to bend loose the ring gently.

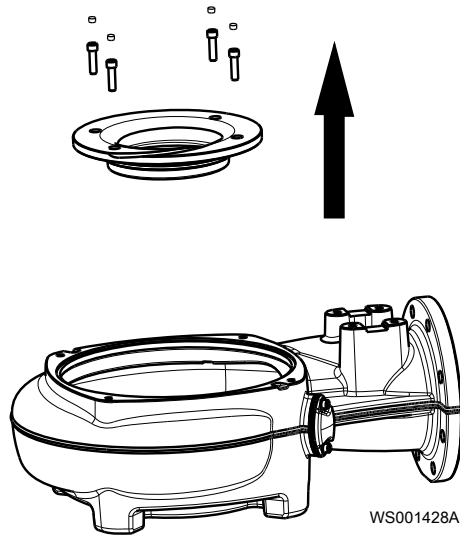
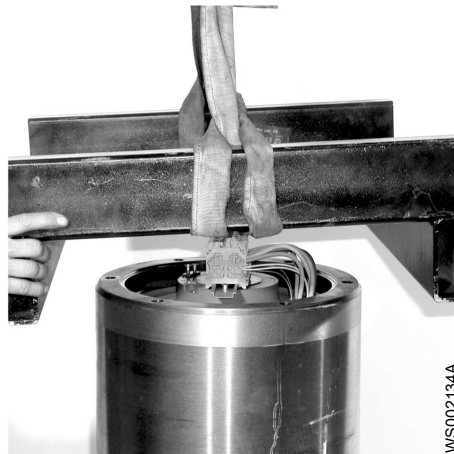

Figure 32: Standard insert ring

#### 4.8.8 Remove the mechanical seal

1. Fit the lifting equipment:

- a) Bolt the assembly/dismantling stand in position. Secure it using the screws for the entrance cover.



- b) Screw a lifting eyebolt into the shaft end.  
Use an M16 eyebolt that is 65-75 mm (2.56-2.95 in) long.

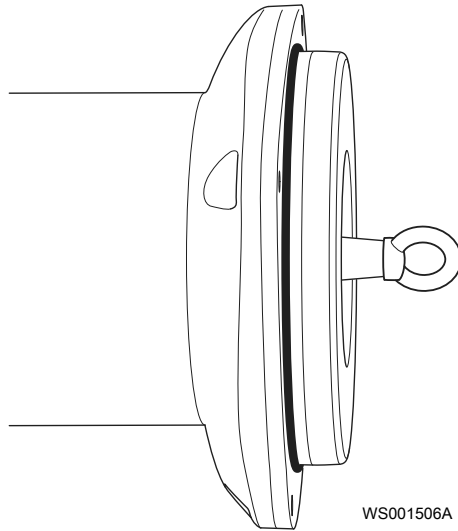

2. Place the drive unit upside down on the stand.

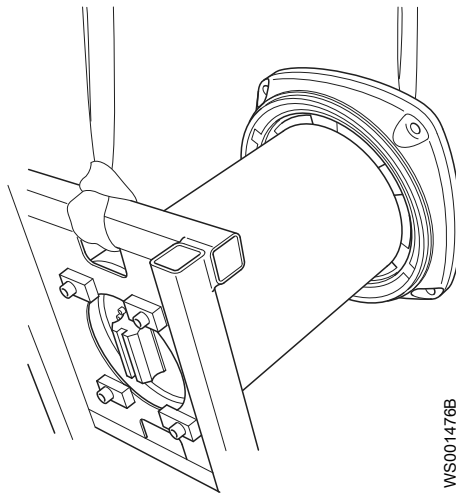

3. Remove the seal housing cover:  
a) Remove the screws that hold the seal housing cover in place.

WS001951A



- b) Fit two lifting eye bolts to the seal housing cover and remove it.



4. Remove the circlip.



Figure 33: With cooling jacket

5. Remove the mechanical seal unit.



Figure 34: With cooling jacket

#### 4.8.9 Remove the adapter

1. Remove the flow diffuser.

Only pumps that are equipped with cooling jacket have a flow diffuser.

WS002127A



2. Remove the screws for the adapter.

WS002108A



3. Fit two lifting eyebolts to the adapter and remove it.



WS001928A

4. Remove the spring.

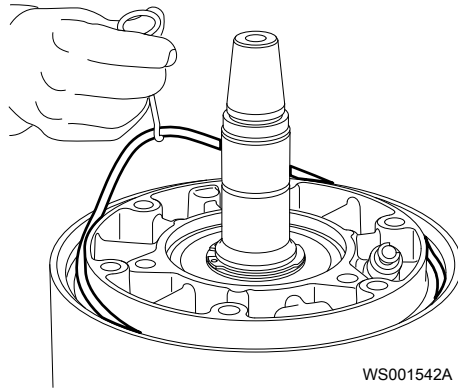

#### 4.8.10 Remove the shaft unit

1. Screw the lifting eyebolt into the shaft end.
2. Carefully lift out the shaft unit.
3. Disconnect the sockets.

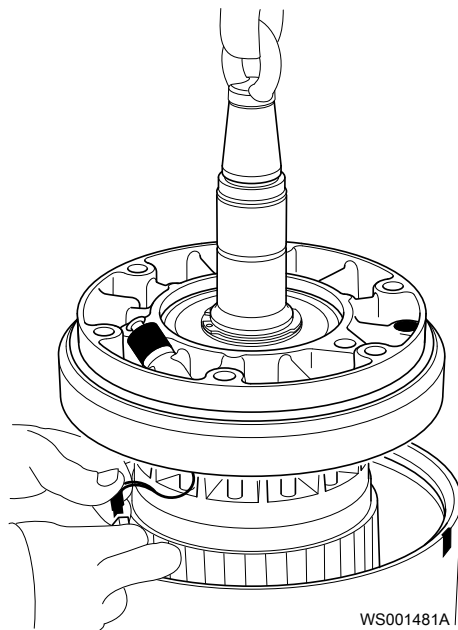

4. Lower the shaft unit back into position.

#### 4.8.11 Remove the bearings

To remove the bearings, you need the disassembly tool (Bearing puller). For more information about the tool, see [Tools](#) on page 95.

#### 4.8.12 Remove the circlips

1. Remove the inner circlip.



2. Remove the washer.
3. Remove the outer circlip.



4. Remove the washer.

#### 4.8.13 Remove the bearing holder

1. Bolt the ring onto the bearing holder.



2. Assemble the disassembling tool.

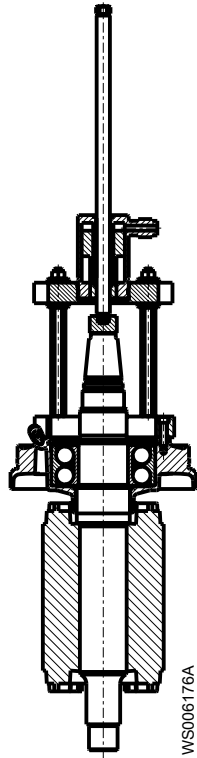

3. Connect the hydraulic hose to the hydraulic unit.



4. Remove the bearing and bearing holder from the rotor shaft.
5. Disconnect the hydraulic hose and lift off the bearing holder with the bearing.

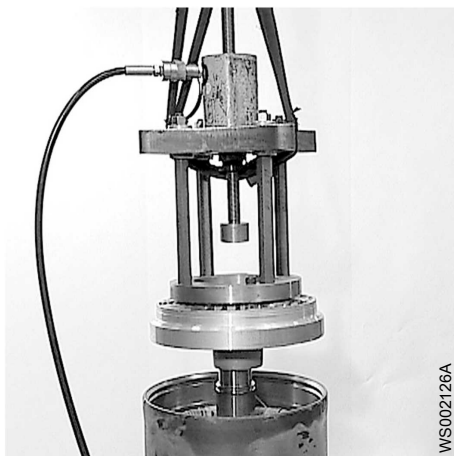

#### 4.8.14 Remove the main bearing from the bearing holder

1. Dismantle the hydraulic unit and let the rest of the tool still be assembled.



2. Add the sleeve from the disassembling tool.
3. Assemble the disassembling tool.

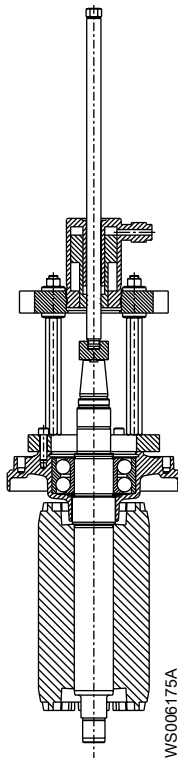

4. Connect the hydraulic hose to the hydraulic unit and press out the bearing.



5. Dismantle the tool and remove the bearing.



#### 4.8.15 Remove the support bearing

1. Lift out the rotor-and-shaft unit from the stator housing.



2. Remove the support bearing from the shaft end using a bearing puller.

### 4.9 Assemble the pump

After the pump is assembled it has to be filled with coolant. For more information, see [Fill with coolant](#) on page 39.

### 4.9.1 Install the bearings

To install the bearings, you need the assembly tool. For more information, see [Tools](#) on page 95.

### 4.9.2 Install the support bearing

1. Put the support washer in the bearing seat in the stator housing.

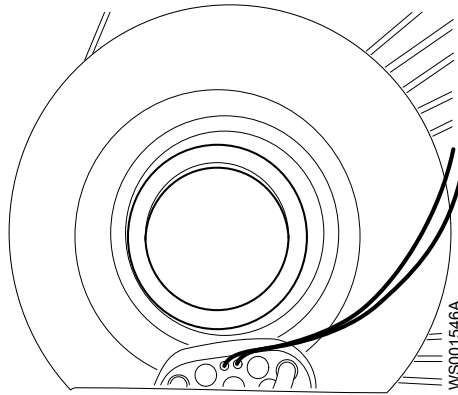

2. Fit the bearing:
  - a) Fit the support bearing onto the shaft.
  - b) Grease the outer surface of the support bearing.
  - c) Put the rotor-and-shaft unit into the stator housing.

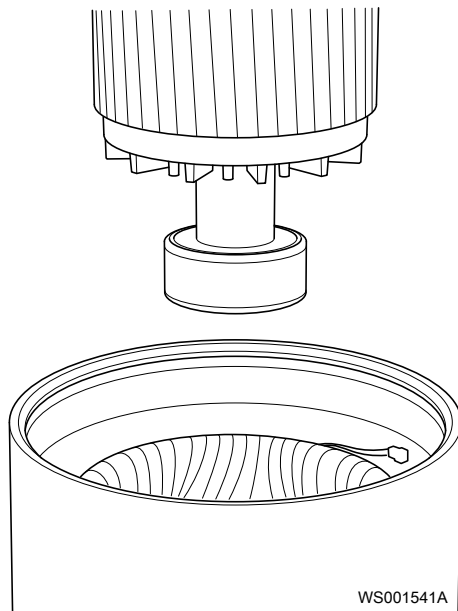

### 4.9.3 Install the main bearing in the bearing holder

1. Place the support washer in the bearing holder.

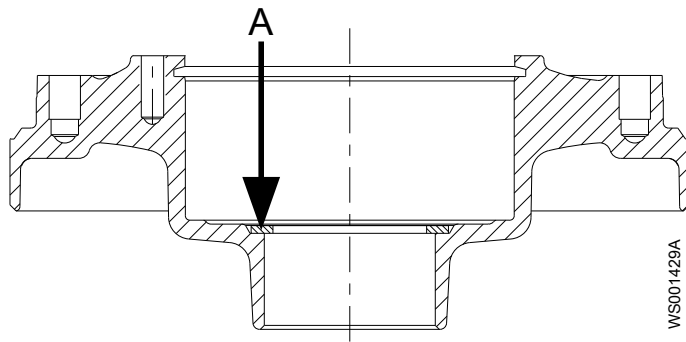

2. Assemble the assembly tool.

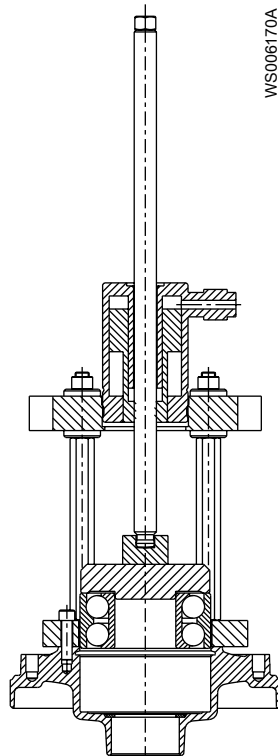

3. Oil the bearing seat.
4. Place the bearing in position, regardless of which side that is facing up.
5. Connect the hydraulic hose to the hydraulic cylinder.
6. Mount the bearing into the bearing holder.

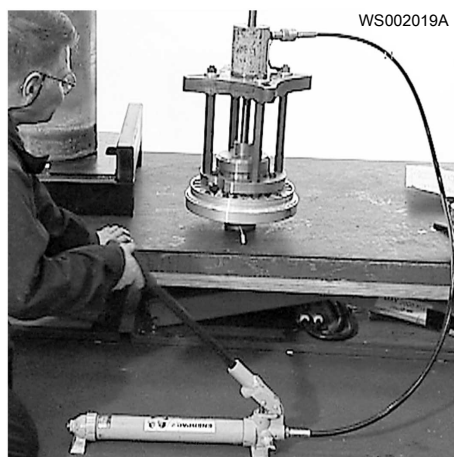

#### 4.9.4 Install the bearing holder

1. Oil the rotor shaft.
2. Place the bearing holder on the shaft.



3. Assemble the assembly tool according to the drawing.

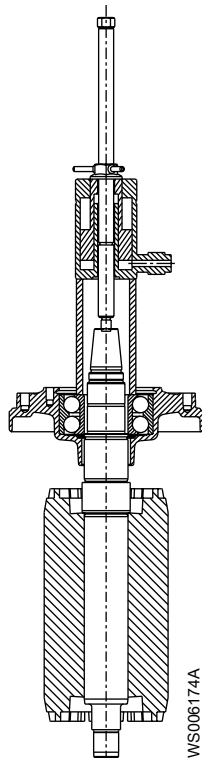

4. Connect the hydraulic hose to the hydraulic cylinder.



5. Mount the bearing holder to the shaft until it bottoms.
6. Remove the hydraulic tool.

#### 4.9.5 Fit the circlips

1. Fit the outer washer.

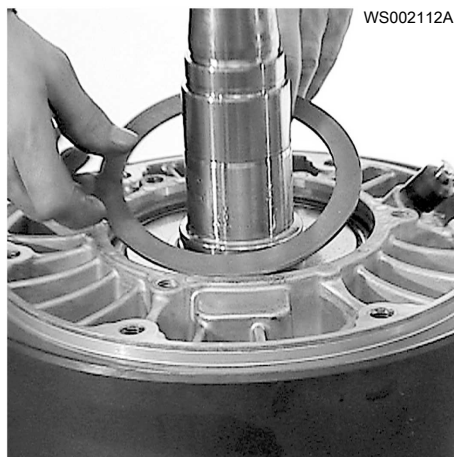

2. Fit the inner washer.



3. Fit the inner circlip.



4. Place and turn the outer circlip with the phased edge facing upwards.

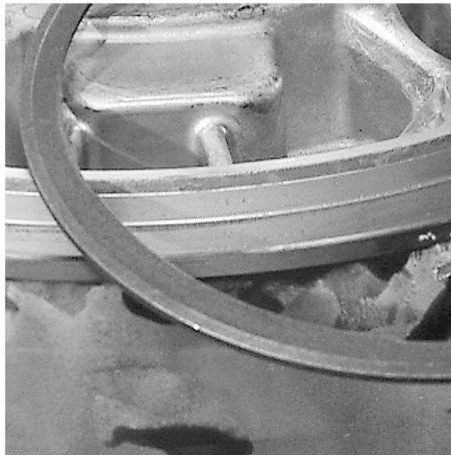

5. Fit the outer circlip.



6. Knock down the circlips and make sure that they enter the grooves properly.
7. Fit a new and greased O-ring on the bearing holder.

WS002118A



#### 4.9.6 Install the shaft unit

1. Screw the lifting eyebolt into the shaft end.
2. Carefully lift the rotor-and-shaft unit with the bearing holder.
3. Grease the surface of the bearing holder.
4. Connect the sockets for the FLS10.

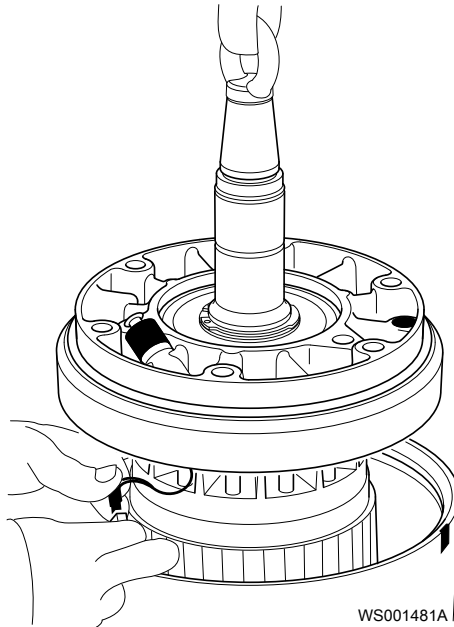

5. Lower the rotor-and-shaft unit, at the same time turning the bearing holder clockwise to the index mark.

Bearing holder index. B indicates that the bearing holder is in line with the marks in the stator housing



WS002136A

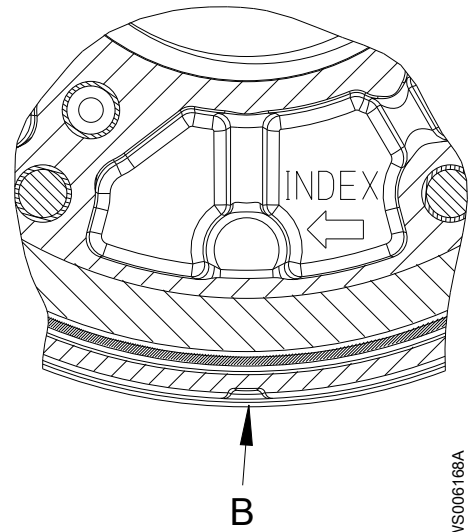

WS006168A

6. Check that the sockets are between the coil end and the stator housing.

#### 4.9.7 Install the adapter

1. Grease the spring and fit it in position.

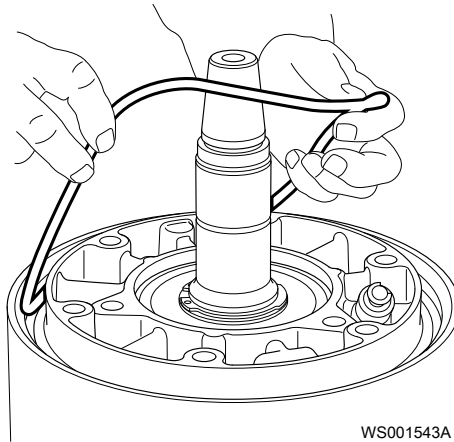

WS001543A

2. Fit a new and greased O-ring at the lower side of the adapter.

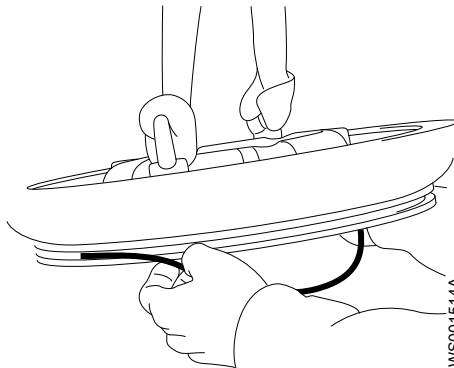

WS001514A

3. Fit a new and greased O-ring on top of the adapter.

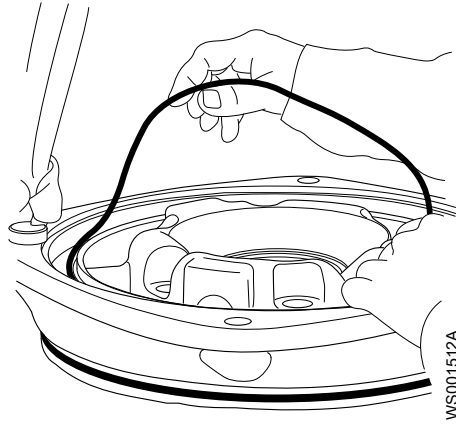

4. Fit the adapter.
5. Fit the screws.  
Tighten the screws diametrically.

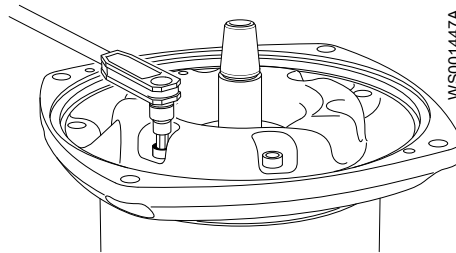

6. Place the flow diffuser in position and press it down until it bottoms out (only for pumps that are equipped with cooling jacket).

WS002127A



#### 4.9.8 Install the mechanical seal

1. Grease the shaft.
2. Fit a new and lubricated mechanical seal unit.  
Check that the drive pin in the shaft engages in the drive groove in the seal unit.



3. Push down the mechanical seal unit.



4. Fit the circlip.



5. Use a suitable sleeve to press down the circlip and make sure that the circlip is in position.



6. Fit new greased O-rings to the seal housing cover



7. Fit the seal housing cover.



8. Tighten the screws diagonally.  
Tightening torque: 76 Nm (56 ft-lb)

WS001951A



9. Fit a new oiled O-ring.



#### 4.9.9 Check the seal tightness

After mounting a new seal, check that it is tight. Leakage can be detected by applying a vacuum in the seal housing, and monitoring any change of pressure over time.

1. Apply a negative differential pressure of about 0.5–0.7 bar (0.5–0.3 bar absolute pressure) in the empty seal housing.
2. After applying the correct pressure, close the evacuation line using a valve.
3. Monitor the change of pressure using a pressure gauge.
4. Compare the result with the maximum allowed pressure change.

$$\Delta P_{\max} = 0.017 \times P_d \times \frac{t}{V}$$

WS004937A

$\Delta P_{\max}$  = maximum allowed pressure change in the test object

$P_d$  = differential pressure (bar)

$t$  = test time (minutes)

$V$  = the volume of the oil chamber, usually  $1.2 \times$  oil volume (liter)



#### **WARNING: Compressed Gas Hazard**

Compressed air/gas may cause parts to be propelled with force. Never apply compressed air/gas to any cavity.

### 4.9.10 Install the insert ring

1. Fit the insert ring into the pump housing.
2. Fit the screws and tighten them diagonally.
3. Fit the plugs into the screw heads.

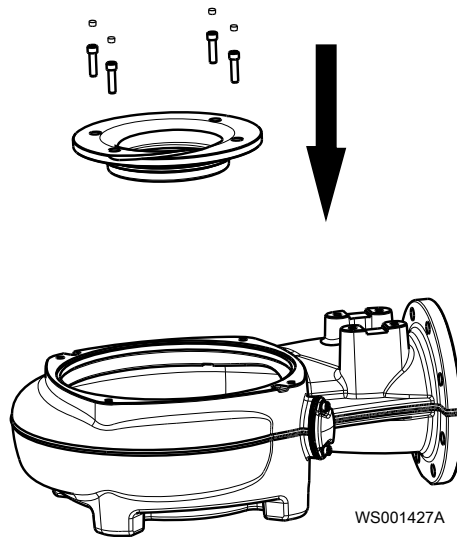

Figure 35: Standard insert ring

### 4.9.11 Replace the impeller

Required tools:

- 14 mm hexagon bit adapter with an extension of at least a 100 mm (4 in)
- Trim tool (24 mm hexagon bar, 300 mm long)
- Rod (wood or plastic) for locking the impeller in place



---

**CAUTION: Cutting Hazard**

Worn parts can have sharp edges. Wear protective clothing.

---



---

**NOTICE:**

When laying the pump on its side, do not allow the weight of the pump to rest on any portion of the impeller. The impeller must not be allowed to make contact with the concrete floor or other hard and rough surfaces.

---



---

**NOTICE:**

If you fail with the impeller installation, you must redo the installation procedure from the beginning.

---

### 4.9.12 Install the impeller: wet installation

1. Prepare the shaft:
  - a) Polish off any flaws by using a fine emery cloth.  
The end of the shaft must be clean and free from burrs.
  - b) Coat the inner conic, the outer cylindrical surfaces, and the thread of the conical sleeve with a thin layer of grease.  
The correct lubrication is grease for bearings, for example Exxon Mobil Unirex N3, Mobil Mobilith SHC 220 or equivalent.

**NOTICE:**

Surplus grease can cause the impeller to become loose. Remove surplus grease from conical and/or cylindrical surfaces of shafts and/or sleeves.

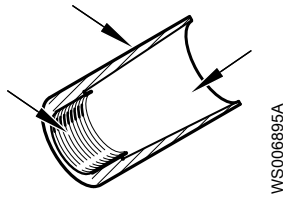

## 2. Mount the impeller:

- a) Adjust the adjustment screw so that it is flush with the sleeve.  
Use the trim tool.

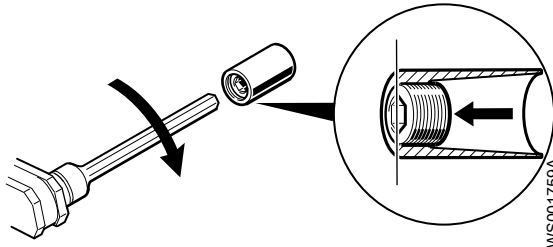

- b) Lift the impeller by attaching a round sling.  
Protect the round sling from the trailing edges of the impeller.



WS002110A

- c) Fit the sleeve into the impeller hub.
- d) Carefully fit the impeller to the shaft.  
To prevent the sleeve and impeller from getting stuck part way on, make sure that they are pushed straight onto the shaft.
- e) Prepare the screw unit. Hand-tighten the center screw to prevent it from falling off.  
For instructions about how to fit the screw unit, see [Handle the screw unit](#) on page 50.  
If the screw unit is not easily screwed back into the shaft, then replace the screw unit.

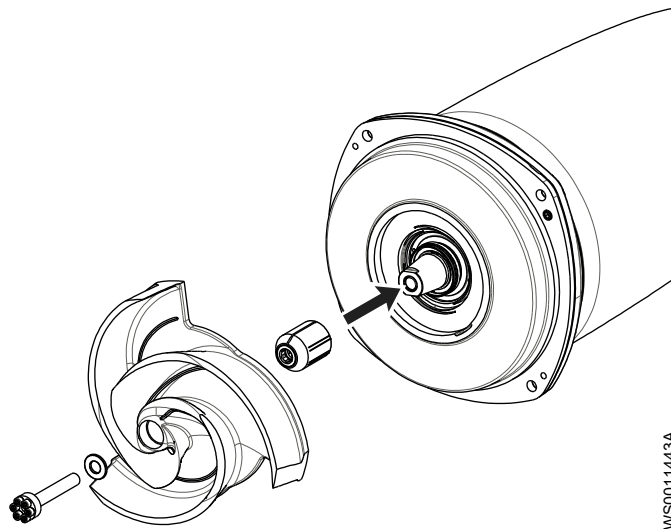

3. Fit the pump housing:
  - a) Fit a new and lubricated O-ring on the seal housing cover.
  - b) Lubricate the pump housing screws.
  - c) Raise the drive unit.
  - d) Place the drive unit into the pump housing.
  - e) Adjust its position so that the inspection hole is on the same side as the flush valve.
  - f) Tighten the pump housing screws in diagonal sequence.

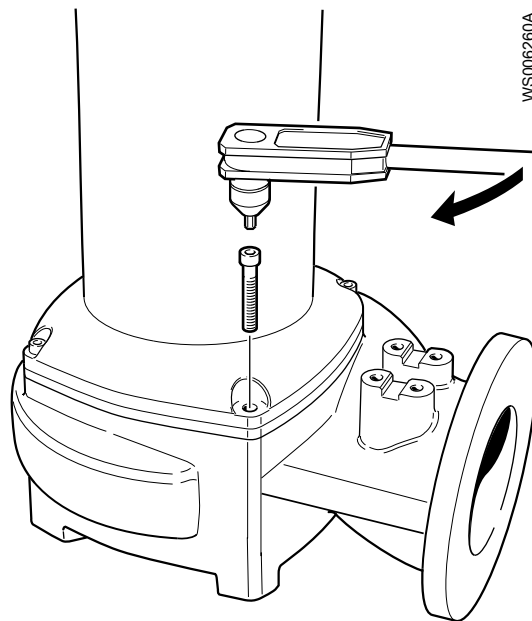

4. Remove the screw unit.
  - a) Place the pump horizontally.
  - b) Lock the impeller in place by inserting a rod through the pump housing outlet.
  - c) Remove the screw unit.
5. Adjust the impeller:
  - a) Using the trim tool, turn the adjustment screw clockwise until the impeller makes contact with the pump housing.  
If the adjustment screw is turned the wrong way, then the impeller will not be possible to remove the next time.
  - b) If possible, tighten it a further 1/8 turn (45°).

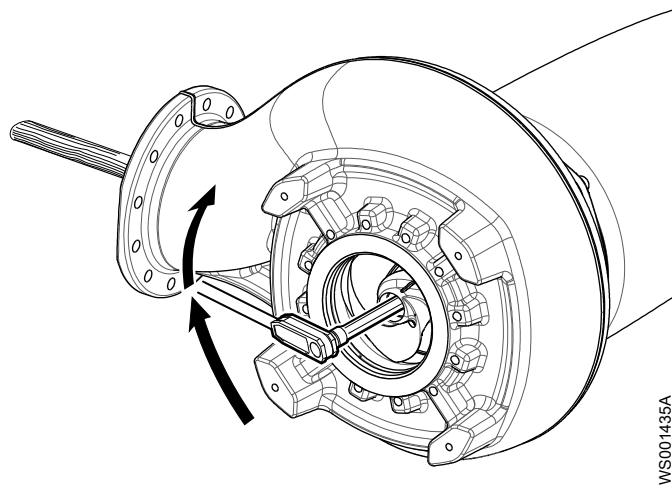

WS001435A

6. Fasten the impeller:
  - a) Fit the screw unit.  
For instructions about how to fit the screw unit, see [Handle the screw unit](#) on page 50.
  - b) Remove the rod that is used to lock the impeller.
  - c) Check that the impeller can rotate freely.

#### 4.9.13 Install the impeller: dry installation

1. Prepare the shaft:
  - a) Polish off any flaws by using a fine emery cloth.  
The end of the shaft must be clean and free from burrs.
  - b) Coat the inner conic, the outer cylindrical surfaces, and the thread of the conical sleeve with a thin layer of grease.  
The correct lubrication is grease for bearings, for example Exxon Mobil Unirex N3, Mobil Mobilith SHC 220 or equivalent.

---

#### NOTICE:

Surplus grease can cause the impeller to become loose. Remove surplus grease from conical and/or cylindrical surfaces of shafts and/or sleeves.

---

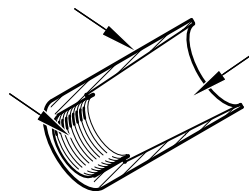

WS006895A

2. Mount the impeller:
  - a) Unscrew the adjustment screw approximately 5 mm (0.2 in).



b) Measure and note the distance A.

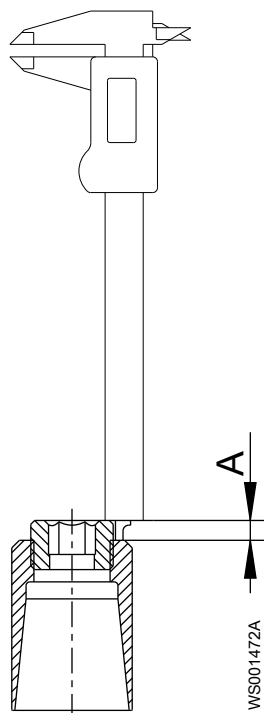

c) Lift the impeller by attaching a round sling.  
Protect the round sling from the trailing edges of the impeller.



WS002110A

- d) Fit the sleeve into the impeller hub.
- e) Carefully fit the impeller to the shaft.  
To prevent the sleeve and impeller from getting stuck part way on, make sure that they are pushed straight onto the shaft.
- f) Prepare the screw unit. Hand-tighten the center screw to prevent it from falling off.  
For instructions about how to fit the screw unit, see [Handle the screw unit](#) on page 50.  
If the screw unit is not easily screwed back into the shaft, then replace the screw unit.

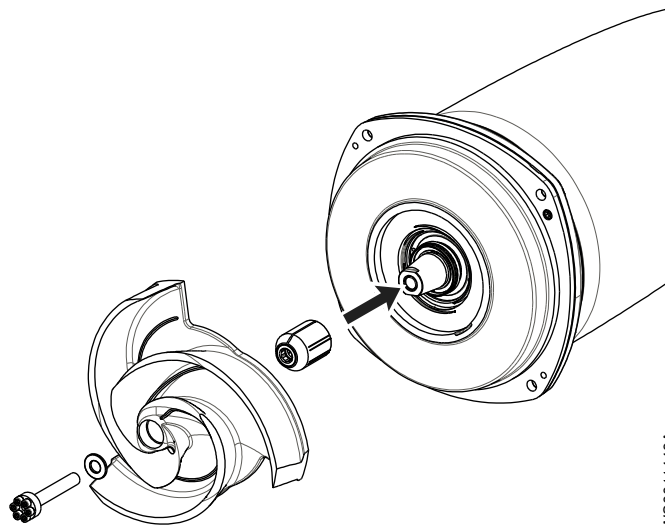

WS0011443A

- g) Tighten the impeller screw.  
Lock the impeller as shown in the figure.



WS002111A

3. Make sure that the O-ring is removed from the seal housing cover.

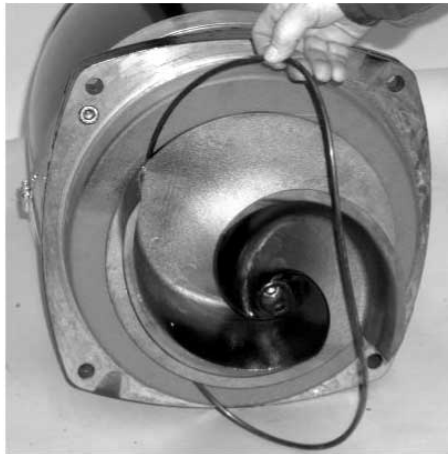

WS002008A

4. Measure the trim distance:

- a) Place the drive unit in the pump housing.

Make sure that the drive unit is parallel with the pump housing by hand-tightening the pump housing screws.

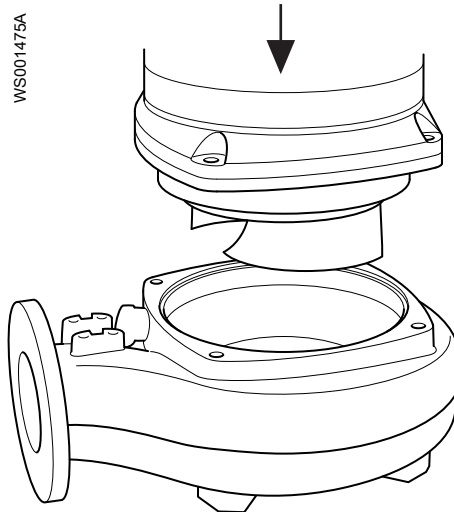

WS001475A

- b) Check the distance between the seal housing cover and the pump housing with a feeler gauge.

Check diagonally at four points.



c) Note the largest distance B.

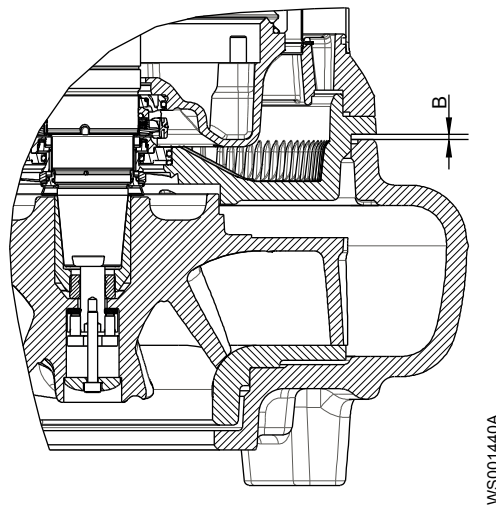

d) Lift the drive unit out of the pump housing and remove the impeller and conical sleeve.

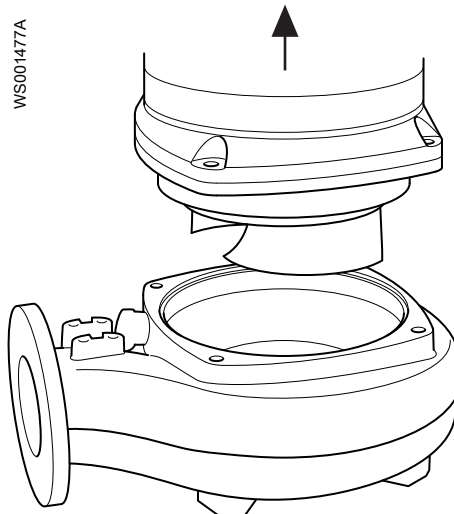

5. Trim to the correct distance:

a) Calculate the measure C according to the formula shown in the image.

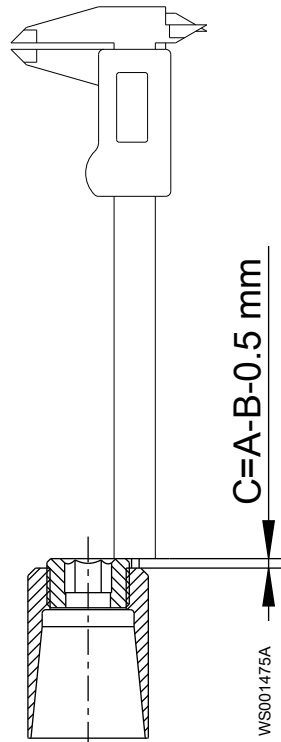

- b) Turn the adjustment screw until C is reached.
6. Fasten the impeller:
- a) Fit the sleeve into the impeller hub.
  - b) Carefully fit the impeller to the shaft.  
To prevent the sleeve and impeller from getting stuck part way on, make sure that they are pushed straight onto the shaft.
  - c) Fit the screw unit.  
For instructions about how to fit the screw unit, see [Handle the screw unit](#) on page 50.
  - d) Tighten the impeller screw.  
Lock the impeller as shown in the figure.



7. Install the drive unit in the pump housing:
- a) Fit a new and lubricated O-ring to the seal housing cover.

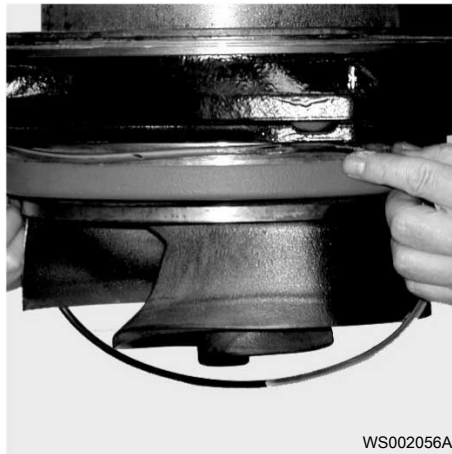

- b) Place the drive unit in the pump housing.  
Make sure that the drive unit is parallel with the pump housing by hand-tightening the pump housing screws.

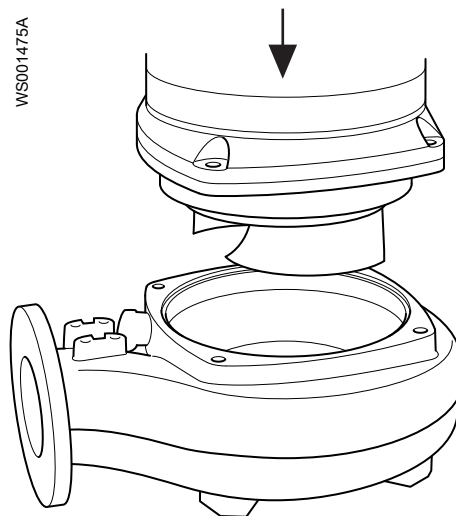

- c) Adjust the position of the drive unit so that the inspection hole is on the same side as the flush valve.  
Tighten the screws diagonally.

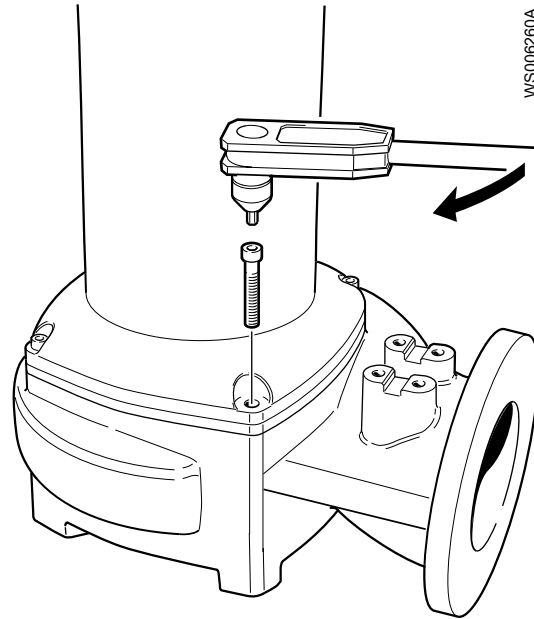

d) Check that the impeller can rotate freely.

If you must adjust the impeller, then perform *Replace the impeller* on page 72 again from the beginning.

#### 4.9.14 Install the cooling jacket

1. If the pump does not stand, then raise the pump.
2. Remove the stand.
3. Fit a new and greased O-ring to the inner cooling jacket.



4. Fit the inner cooling jacket.

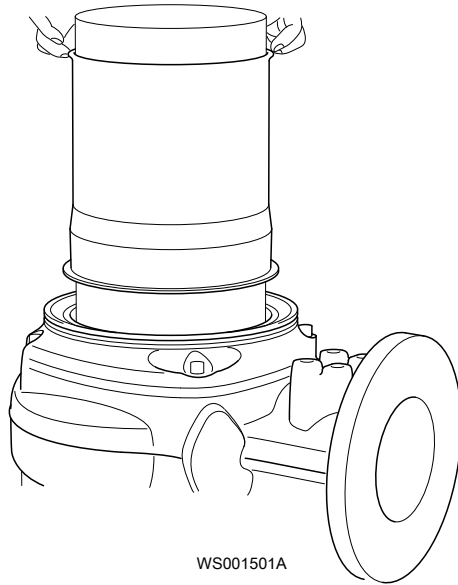

5. Fasten the inner cooling jacket in one of the following ways:
- Fit the washers and screws and tighten them diagonally.

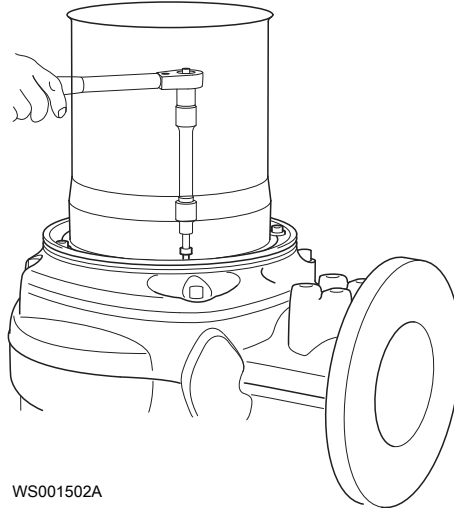

Figure 36: Mounted with screws

- Press the wire bows in position as shown in the illustration.



Figure 37: Mounted with wire bows

6. Fit a new and greased O-ring to the adapter.

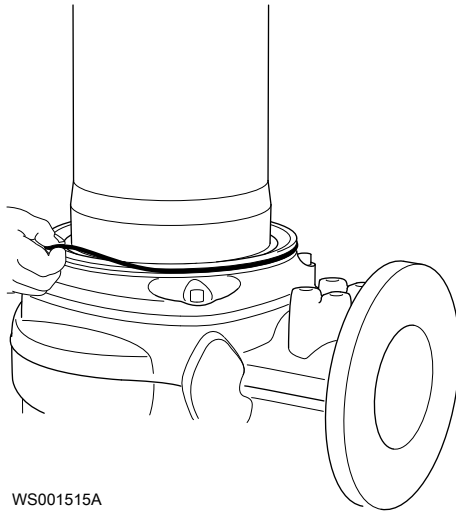

WS001515A

7. Fit the outer cooling jacket.



WS002113A

#### 4.9.15 Install the connection housing

1. Install a new O-ring for the connection housing. Put the connection housing in place and tighten the screws.

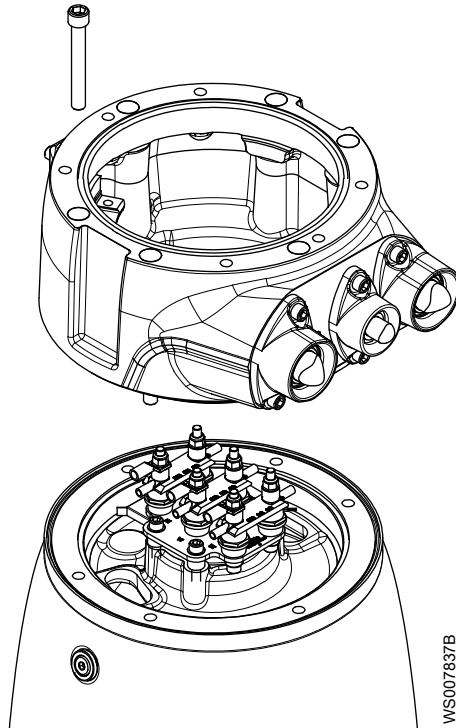

2. Connect the motor cable leads. See [Make the electrical connections](#) on page 11.

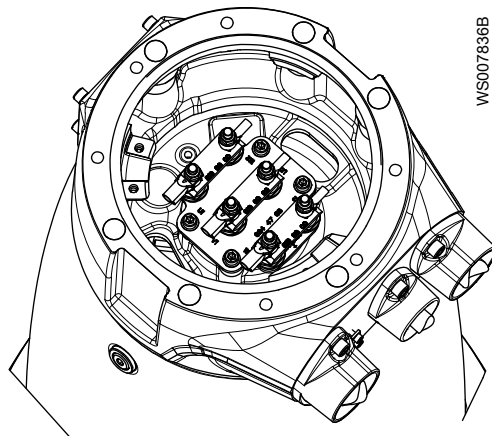

3. Turn back the terminal plate to the top of the connection housing.

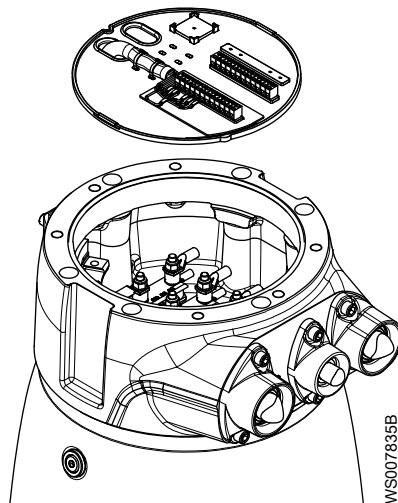

4. Connect the sensor leads to the terminal board. If the monitoring cable is disconnected, then connect it to the terminal board. See [Make the electrical connections](#) on page 11.

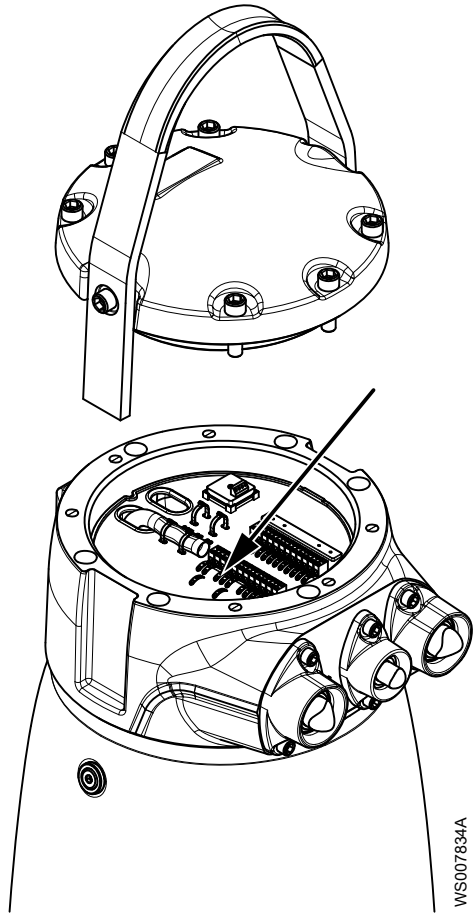

5. Install a new O-ring in the cover. Put the cover in place and tighten the screws.

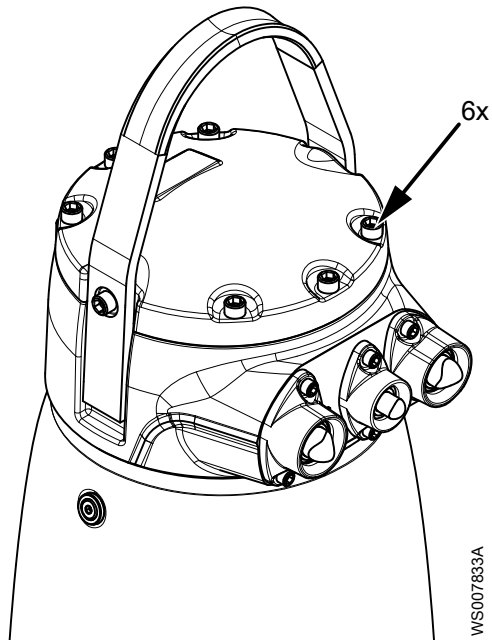

## 4.10 Pumps with MAS 801: Replace the PEM

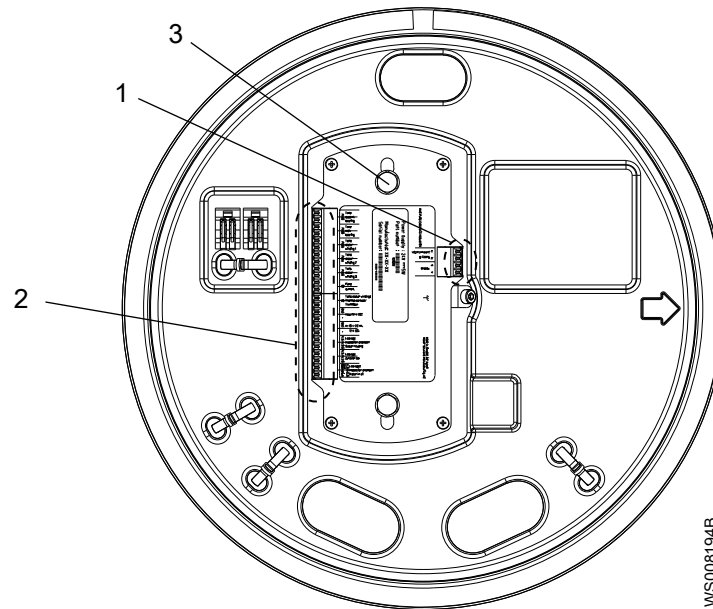

1. PEM communication terminals
2. PEM control terminals
3. Screws securing PEM

1. Disconnect the communication terminals.
2. Disconnect the control terminals on the PEM.  
For specially-approved pumps, do not disconnect T3 and T4 from the separate plinth.
3. Disconnect the functional ground.
4. Remove the two screws securing the PEM.
5. Lift out the PEM.
6. Fit the new PEM into place. Secure with two screws.
7. Connect the functional ground.
8. Connect the control terminals.  
For specially-approved pumps, do not use connections 51 and 63 on the PEM. For EX-pumps, T3 and T4 must be connected to the separate plinth.
9. Connect the communication terminals.
10. To download information to the PEM, see the System Installation and Operation (SIO) Manual for the MAS 801 monitoring equipment.

# 5 Troubleshooting

## 5.1 Electrical troubleshooting



### **DANGER: Electrical Hazard**

Troubleshooting a live control panel exposes personnel to hazardous voltages. Electrical troubleshooting must be done by a qualified electrician.

Follow these guidelines when troubleshooting:

- Disconnect and lock out the power supply except when conducting checks that require voltage.
- Make sure that no one is near the unit when the power supply is reconnected.
- When troubleshooting electrical equipment, use the following:
  - Universal instrument multimeter
  - Test lamp (continuity tester)
  - Wiring diagram

## 5.2 The pump does not start



### **DANGER: Crush Hazard**

Moving parts can entangle or crush. Always disconnect and lock out power before servicing to prevent unexpected startup. Failure to do so could result in death or serious injury.



### **NOTICE:**

Do NOT override the motor protection repeatedly if it has tripped. Doing so may result in equipment damage.

Cause	Remedy
An alarm signal has been triggered on the control panel.	Check that: <ul style="list-style-type: none"> <li>• The impeller rotates freely.</li> <li>• The sensor indicators do not indicate an alarm.</li> <li>• The overload protection is not tripped.</li> </ul>
The pump does not start automatically, but can be started manually.	Check that: <ul style="list-style-type: none"> <li>• The start level regulator is functioning. Clean or replace if necessary.</li> <li>• All connections are intact.</li> <li>• The relay and contactor coils are intact.</li> <li>• The control switch (Man/Auto) makes contact in both positions.</li> </ul> Check the control circuit and functions.

Cause	Remedy
The installation is not receiving voltage.	Check that: <ul style="list-style-type: none"> <li>• The main power switch is on.</li> <li>• There is control voltage to the start equipment.</li> <li>• The fuses are intact.</li> <li>• There is voltage in all phases of the supply line.</li> <li>• All fuses have power and that they are securely fastened to the fuse holders.</li> <li>• The overload protection is not tripped.</li> <li>• The motor cable is not damaged.</li> </ul>
The impeller is stuck.	Clean: <ul style="list-style-type: none"> <li>• The impeller</li> <li>• The sump in order to prevent the impeller from clogging again.</li> </ul>

If the problem persists, then contact a sales or authorized service representative.

Always state the serial number of the product, see [Product Description](#) on page 7.

### 5.3 The pump does not stop when a level sensor is used



#### **DANGER: Crush Hazard**

Moving parts can entangle or crush. Always disconnect and lock out power before servicing to prevent unexpected startup. Failure to do so could result in death or serious injury.



Cause	Remedy
The pump is unable to empty the sump to the stop level.	Check that: <ul style="list-style-type: none"> <li>• There are no leaks from the piping and/or discharge connection.</li> <li>• The impeller is not clogged.</li> <li>• The non-return valve(s) are functioning properly.</li> <li>• The pump has adequate capacity. For information: Contact a sales or authorized service representative.</li> </ul>
There is a malfunction in the level-sensing equipment.	<ul style="list-style-type: none"> <li>• Clean the level regulators.</li> <li>• Check the functioning of the level regulators.</li> <li>• Check the contactor and the control circuit.</li> <li>• Replace all defective items.</li> </ul>
The stop level is set too low.	Raise the stop level.

If the problem persists, then contact a sales or authorized service representative.

Always state the serial number of the product, see [Product Description](#) on page 7.

### 5.4 The pump starts-stops-starts in rapid sequence

Cause	Remedy
The pump starts due to back-flow which fills the sump to the start level again.	Check that: <ul style="list-style-type: none"> <li>• The distance between the start and stop levels is sufficient.</li> <li>• The non-return valve(s) work(s) properly.</li> <li>• The length of the discharge pipe between the pump and the first non-return valve is sufficiently short.</li> </ul>

Cause	Remedy
The self-holding function of the contactor malfunctions.	Check: <ul style="list-style-type: none"> <li>• The contactor connections.</li> <li>• The voltage in the control circuit in relation to the rated voltages on the coil.</li> <li>• The functioning of the stop-level regulator.</li> <li>• Whether the voltage drop in the line at the starting surge causes the contactor's self-holding malfunction.</li> </ul>

If the problem persists, then contact a sales or authorized service representative.

Always state the serial number of the product, see [Product Description](#) on page 7.

## 5.5 The pump runs but the motor protection trips



### DANGER: Crush Hazard

Moving parts can entangle or crush. Always disconnect and lock out power before servicing to prevent unexpected startup. Failure to do so could result in death or serious injury.



### NOTICE:

Do NOT override the motor protection repeatedly if it has tripped. Doing so may result in equipment damage.

Cause	Remedy
The motor protection is set too low.	Set the motor protection according to the data plate and if applicable the cable chart.
The impeller is difficult to rotate by hand.	<ul style="list-style-type: none"> <li>• Clean the impeller.</li> <li>• Clean out the wet well.</li> <li>• Check that the impeller is correctly trimmed.</li> </ul>
The drive unit cannot receive full voltage on all three phases.	<ul style="list-style-type: none"> <li>• Check the fuses. Replace fuses that have tripped.</li> <li>• If the fuses are intact, then notify a certified electrician.</li> </ul>
The phase currents change, or they are too high.	Contact a sales or authorized service representative.
The insulation between the phases and ground in the stator is defective.	<ol style="list-style-type: none"> <li>1. Use an insulation tester. Use a 1000 VDC insulation and continuity tester to check that the insulation between the phases, and between any phase and ground, is &gt; 5 megohms.</li> <li>2. If the insulation is less, then do the following: Contact a sales or authorized service representative.</li> </ol>
The density of the pumped fluid is too high.	Make sure that the maximum density is 1100 kg/m <sup>3</sup> (9.2 lb/US gal) <ul style="list-style-type: none"> <li>• Change the impeller, or</li> <li>• Change to a more applicable pump</li> <li>• Contact a sales or authorized service representative.</li> </ul>
There is a malfunction in the overload protection.	Replace the overload protection.

If the problem persists, then contact a sales or authorized service representative.

Always state the serial number of the product, see [Product Description](#) on page 7.

## 5.6 The pump delivers too little or no water



### DANGER: Crush Hazard

Moving parts can entangle or crush. Always disconnect and lock out power before servicing to prevent unexpected startup. Failure to do so could result in death or serious injury.



### NOTICE:

Do NOT override the motor protection repeatedly if it has tripped. Doing so may result in equipment damage.

Cause	Remedy
The impeller rotates in the wrong direction.	<ul style="list-style-type: none"> <li>If it is a 3-phase pump, then transpose two phase leads.</li> <li>If it is a 1-phase pump, then do the following: Contact a sales or authorized service representative.</li> </ul>
One or more of the valves are set in the wrong positions.	<ul style="list-style-type: none"> <li>Reset the valves that are set in the wrong position.</li> <li>Replace the valves, if necessary.</li> <li>Check that all valves are correctly installed according to media flow.</li> <li>Check that all valves open correctly.</li> </ul>
The impeller is difficult to rotate by hand.	<ul style="list-style-type: none"> <li>Clean the impeller.</li> <li>Clean out the sump.</li> <li>Check that the impeller is properly trimmed.</li> </ul>
The pipes are obstructed.	To ensure a free flow, clean out the pipes.
The pipes and joints leak.	Find the leaks and seal them.
There are signs of wear on the impeller, pump, and casing.	Replace the worn parts.
The liquid level is too low.	<ul style="list-style-type: none"> <li>Check that the level sensor is set correctly.</li> <li>Depending on the installation type, add a means for priming the pump, such as a foot valve.</li> </ul>

If the problem persists, then contact a sales or authorized service representative.

Always state the serial number of the product, see [Product Description](#) on page 7.

# 6 Technical Reference

## 6.1 Application limits

Data	Description
Liquid temperature	40°C (104°F) maximum For P-installations without a cooling jacket, the pump can be operated only when the sump level is at least 10 mm (0.4 in) above the stator housing. Warm-liquid version: 70°C (158°F) maximum Warm-liquid version must have cooling jacket.
pH of the pumped media (liquid)	5.5–14
Liquid density	1100 kg/m <sup>3</sup> (9.2 lb for each US gal) maximum
Depth of immersion	Maximum 20 m (65 ft)
Other	For the specific weight, current, voltage, power ratings, and speed of the pump, see the data plate of the pump.

## 6.2 Pump parts

For information about the different hydraulic ends and parts, see Parts List.

3315

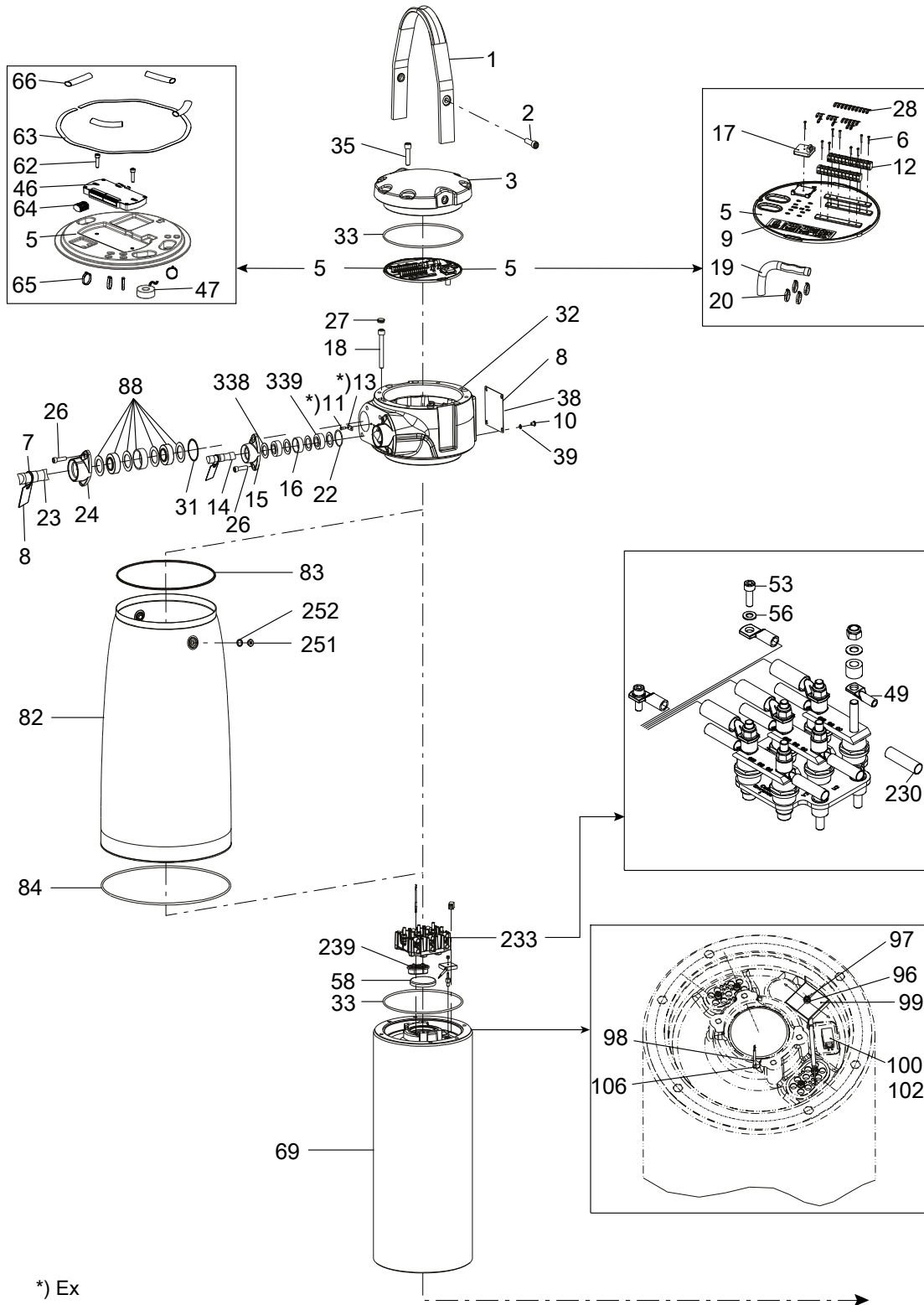

31586F

3315

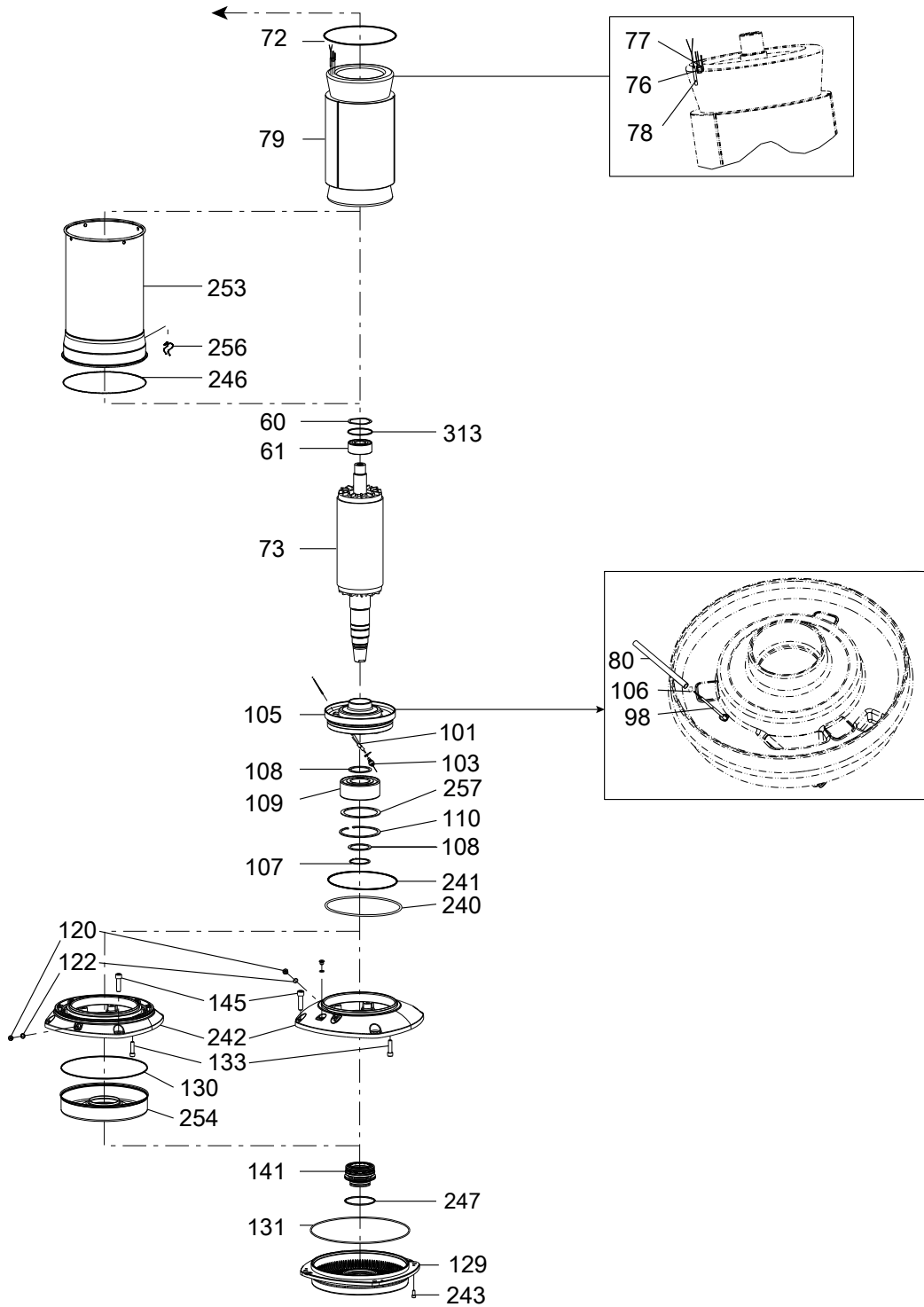

31587A

## 6.3 Tools

### List of tools

Part number	Denomination	Range of use
839542	Oil gun	Inspection room
840803	Circlip pliers (SGA 40–100 mm)	Mechanical seal unit, outer bearing
840812	Circlip pliers	Outer bearing
840844	Cable lug pliers	Motor cable
840860	Crow bar	Mechanical seal unit
841016	Ratchet handle	Sockets
840875	Press-dies set	Motor cable
840876	Press-dies set	Motor cable
840877	Press-dies set	Motor cable
841140	Combination wrench (17 mm)	Level switch
841301	Hexagon bit adapter (14 mm)	Impeller screw, entrance cover, lifting handle, bearing holder
841303	Hexagon bit adapter (5 mm)	Terminal rail, earthing, inner cooling jacket
841305	Hexagon bit adapter (8 mm)	Plugs, flush valve cover
841306	Hexagon bit adapter (10 mm)	Cable entry, seal housing cover
841307	Hexagon bit adapter (17 mm)	Pump housing
841362	Puller	Support bearing
841368	Hydraulic unit	Main bearing
841390	Socket wrench	Impeller
841418	Reduction stud	Pump housing
841555	Extension bar	Sockets
842015	Torque changing	Pump housing
3329100	Spring puller	Spring
3984000	Mounting socket	Mechanical seal unit
7360300	Trim tool	Impeller
6056900	Bearing puller	Main bearing
6057000	Stand	Pump fixation
6895407	Mounting/dismounting tool	Stator
7299400	Mounting socket	Pt100, main bearing

Table 3: Bearing puller 6056900

Position	Part number	Denomination
1	4021600	Nut
2	4324300	Washer
3	4324400	Cross piece
4	4324800	Stud
5	4325000	Stud
6	4438500	Washer
7	4438600	Puller screw complete
8	6056400	Hexagon head screw

<b>Position</b>	<b>Part number</b>	<b>Denomination</b>
9	6056500	Ring
10	6056600	Sleeve
11	6056700	Cross piece
12	6056800	Plate
13	830453	Hexagon socket head screw M12x45
14	823729	Plain washer
15	822361	Hexagon nut M16
16	805782	Tension pin FRP 5x24

## Disassembly and assembly tools for the bearing holder

Table 4: Bearing puller

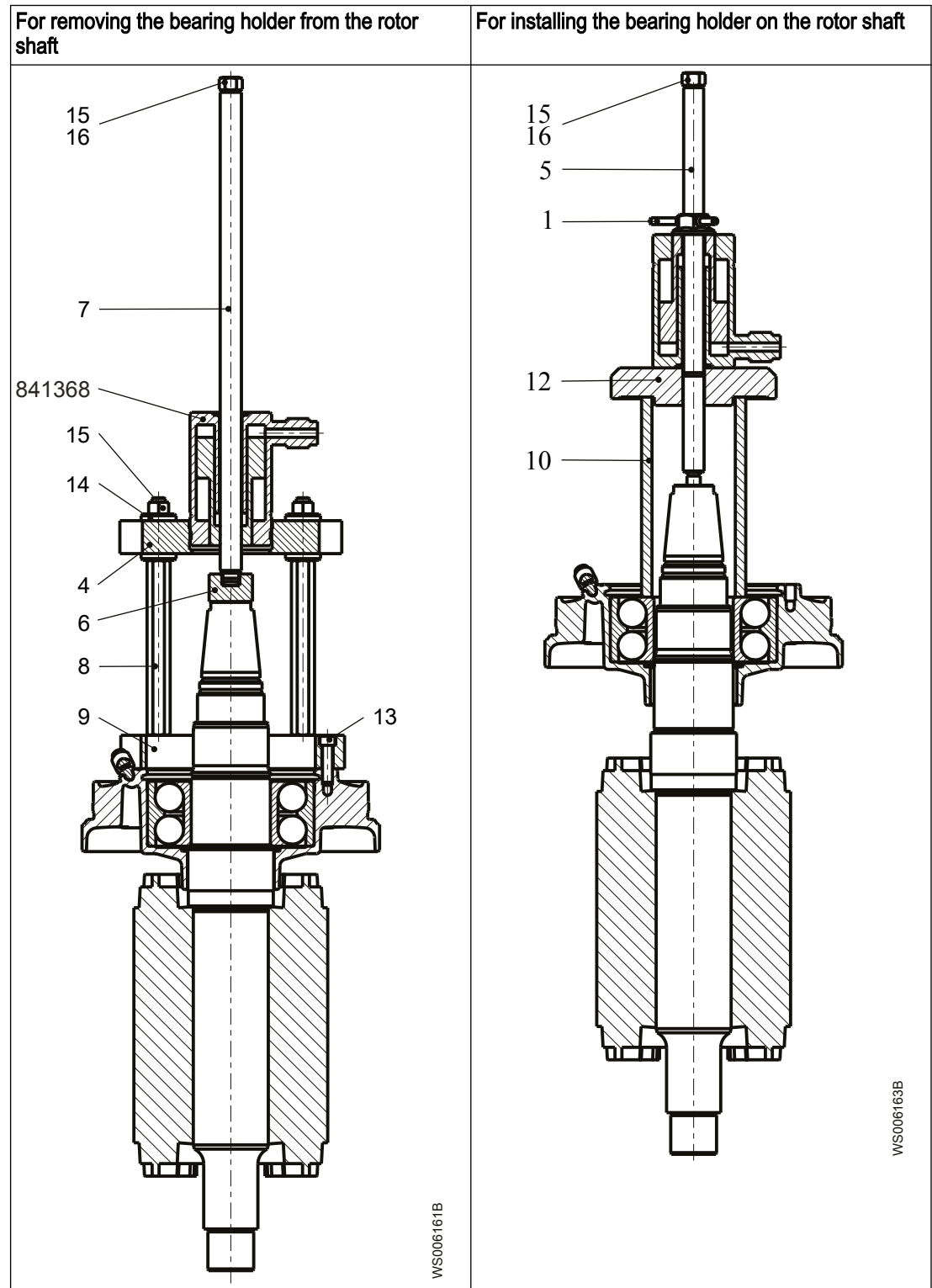

Disassembly and assembly tools for the main bearing

Table 5: Bearing puller

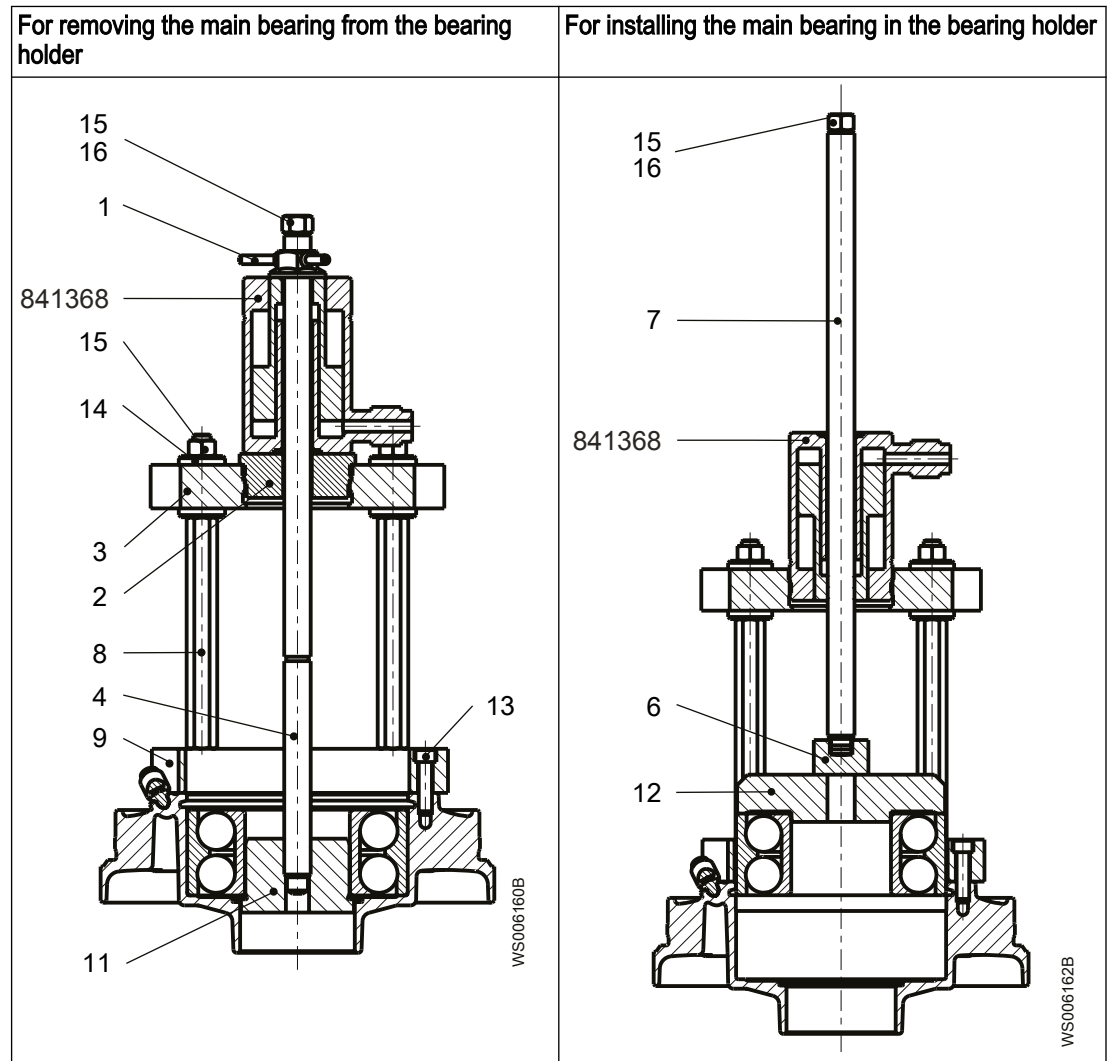

6.4 Sensor characteristics

Sensor	Measured value
Thermal contact	0–3 ohm unless the wires are long The thermal contacts open at 140°C (285°F)
Thermistor	Resistance at normal temperature: <ul style="list-style-type: none"> <li>• One thermistor, 50–100 ohm</li> <li>• Three thermistors in series, 150–300 ohm</li> </ul>
Pt100	<ul style="list-style-type: none"> <li>• 100 ohm at 0°C (32°F)</li> <li>• 107.79 ohm at room temperature, 20°C (68°F)</li> <li>• 138.5 ohm at 100°C (212°F)</li> </ul> The resistance increases by 0.385 ohm for each °C.
	<p><b>NOTICE:</b></p> Never connect the Pt100 transducer to a voltage higher than 2.5 V.
FLS	<ul style="list-style-type: none"> <li>• Normal: 1530 ohm</li> <li>• Alarm: 330 ohm</li> </ul>

Sensor	Measured value
FLS10	<ul style="list-style-type: none"> <li>• Normal: 1200 ohm</li> <li>• Alarm: 430 ohm</li> </ul>

## 6.5 Wiring diagram: MiniCAS II

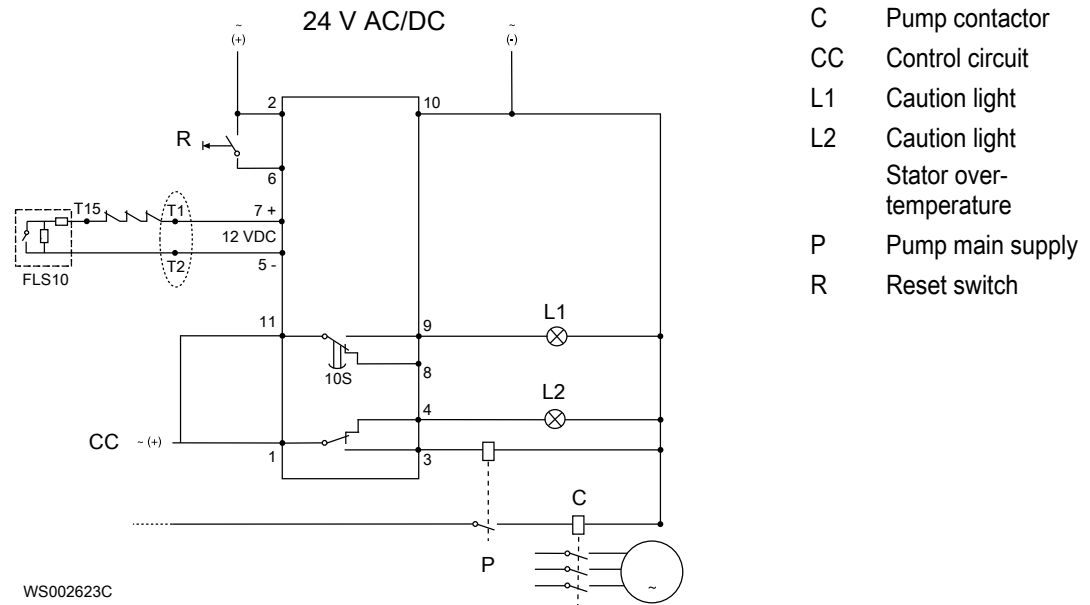

## 6.6 Torque values

All screws and nuts must be lubricated to achieve correct tightening torque. Screws that are screwed into stainless steel must have the threads coated with applicable lubricants to prevent seizing.

If there is a question regarding the tightening torques, then contact a sales or authorized service representative.

### Screws and nuts

Table 6: Stainless steel, A2 and A4, torque Nm (lbf-ft)

Property class	M4	M5	M6	M8	M10	M12	M16	M20	M24	M30
50	1.0 (0.74)	2.0 (1.5)	3.0 (2.2)	8.0 (5.9)	15 (11)	27 (20)	65 (48)	127 (93.7)	220 (162)	434 (320)
70, 80	2.7 (2)	5.4 (4)	9.0 (6.6)	22 (16)	44 (32)	76 (56)	187 (138)	364 (268)	629 (464)	1240 (915)
100	4.1 (3)	8.1 (6)	14 (10)	34 (25)	66 (49)	115 (84.8)	248 (183)	481 (355)	—	—

Table 7: Steel, torque Nm (lbf-ft)

Property class	M4	M5	M6	M8	M10	M12	M16	M20	M24	M30
8.8	2.9 (2.1)	5.7 (4.2)	9.8 (7.2)	24 (18)	47 (35)	81 (60)	194 (143)	385 (285)	665 (490)	1310 (966.2)

Property class	M4	M5	M6	M8	M10	M12	M16	M20	M24	M30
10.9	4.0 (2.9)	8.1 (6)	14 (10)	33 (24)	65 (48)	114 (84)	277 (204)	541 (399)	935 (689)	1840 (1357)
12.9	4.9 (3.6)	9.7 (7.2)	17 (13)	40 (30)	79 (58)	136 (100)	333 (245)	649 (480)	1120 (825.1)	2210 (1630)

Table 8: Brass, torque Nm (lbf-ft)

M5	M8	M10
2.7 (2.0)	11 (8.1)	22 (16.2)

**Hexagon screws with countersunk heads**

For hexagon socket head screws with countersunk head, maximum torque for all property classes must be 80% of the values for property class 8.8.

**Round nuts with set screws**

Table 9: Set screw, torque Nm (lbf-ft)

The torque values are only valid for the set screw, and not for the round nut.

M8	M10
18 (13)	35 (26)



# Xylem |'zīləm|

- 1) The tissue in plants that brings water upward from the roots;
- 2) a leading global water technology company.

We're a global team unified in a common purpose: creating advanced technology solutions to the world's water challenges. Developing new technologies that will improve the way water is used, conserved, and re-used in the future is central to our work. Our products and services move, treat, analyze, monitor and return water to the environment, in public utility, industrial, residential and commercial building services settings. Xylem also provides a leading portfolio of smart metering, network technologies and advanced analytics solutions for water, electric and gas utilities. In more than 150 countries, we have strong, long-standing relationships with customers who know us for our powerful combination of leading product brands and applications expertise with a strong focus on developing comprehensive, sustainable solutions.

**For more information on how Xylem can help you, go to [www.xylem.com](http://www.xylem.com)**



Xylem Water Solutions Global  
Services AB 556782-9253  
361 80 Emmaboda  
Sweden  
Tel: +46-471-24 70 00  
Fax: +46-471-24 74 01  
<http://tpi.xylem.com>  
[www.xylemwatersolutions.com/  
contacts/](http://www.xylemwatersolutions.com/contacts/)

Visit our Web site for the latest version of this document and more information

The original instruction is in English. All non-English instructions are translations of the original instruction.

© 2014 Xylem Inc.



**NP 3231/706 3~ 480**

Created On: 8/11/25

## NP 3231/706 3~ 480 | Configuration Summary

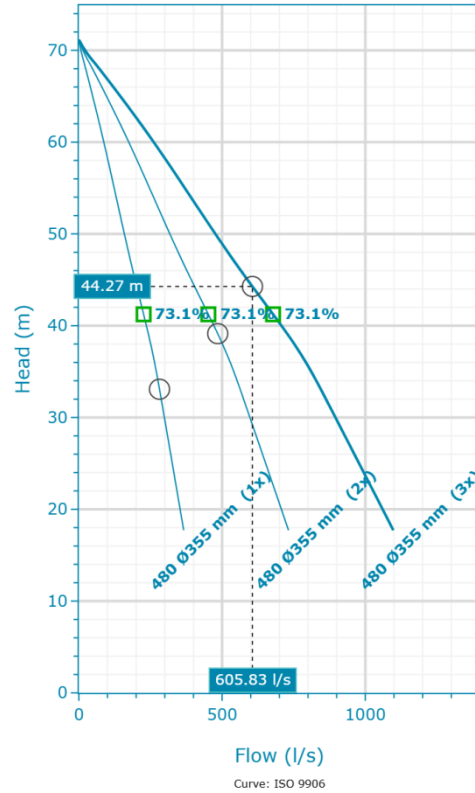

Nominal (mean) data shown. Under- and over-performance from this data should be expected due to standard manufacturing tolerances. Please consult your local Flygt representative for performance guarantees.

### GENERAL

<b>Explosion Proof</b>	<b>Impeller Diameter</b>
No	355 mm
<b>Max. Pumped Media Temp.</b>	
40 °C	

### MATERIAL AND COATING

<b>Impeller Material</b>
Hard-Iron
<b>Volute Material</b>
Grey Cast Iron

### MOTOR

<b>Rated Voltage</b>	<b>Motor Efficiency Class</b>
600 V	Premium (IE3)
<b>Coupling</b>	<b>Rated Power</b>
D	138 kW
	<b>Cooling Jacket</b>
	Closed Loop Cooling System

### INSTALLATION

<b>Installation Type</b>
P - Semi-Permanent, Wet

# NP 3231/706 3~ 480 | Product Details

## Description

### N 3231

Flygt N-pumps take on the toughest applications and get the job done. Every component is designed and manufactured to deliver sustained high efficiency. Thanks to patented N-technology with its innovative self-cleaning impeller, Flygt N-pumps deliver the highest total efficiency. They lower your energy bill and reduce unplanned maintenance costs. That adds up to total peace of mind – and big savings over the long term. Most solid objects entering the pump will pass through the impeller between the impeller vanes. If an object gets caught on the leading edge of one of the vanes, it will slide along the backswept shape towards the perimeter of the inlet. Due to the mechanical self-cleaning design, a sludge concentration up to 8% can easily be pumped.

### Flexible and Modular Design

- This self-cleaning pump features innovative functions that make it the best choice for a broad range of applications.
- The modular hydraulic design enables you to tailor the hydraulics to meet the requirements of virtually any application.
- Replaceable wear ring in two materials, gray iron or Hard-Iron for different operation conditions
- Hardened gray iron impeller for typical wastewater applications
- Hard-Iron impeller for abrasive and corrosive applications
- Stainless steel impeller for special applications that require duplex stainless steel
- Short shaft overhang reduces shaft deflection and increases seal and bearing life
- Motor designed for submersible use. Heat is concentrated to the stator core for improved cooling properties.
- The double mechanical seal system consists of two sets of mechanical shaft seals that work independently to provide double security. Available in Tungsten carbide (WCCR) or Silicone carbide (SiC) depending on pumped media.
- Motor cable SUBCAB® specially developed for submersible use.
- Offers flexible cooling systems, e.g. closed loop cooling system, media cooled or external cooling.

### Product Features

- State-of-the-art wastewater pump with N-technology
- Sustained high efficiency with energy savings up to 25%
- Flexible and modular design
- Robust and reliable

## Construction Materials

Impeller Material	Volute Material	Stator Cover Material
Hard-Iron	Grey Cast Iron	-

## Motor

<b>Rated Power</b> 138 kW	<b>Number Of Phases</b> 3	<b>Start Current Ratio</b> 6.29	<b>Motor Issue</b> 11
<b>Motor Denomination</b> 43-30-4ID	<b>Rated Motor Speed</b> 1,785 RPM	<b>Insulation Class</b> H	<b>Locked Rotor Code</b> G
<b>Motor Efficiency Class</b> Premium (IE3)	<b>Rated Voltage</b> 600 V	<b>Approval</b> Standard	<b>Max starts per hour</b> 10
<b>Version Code</b> 000	<b>Rated Current</b> 162 A	<b>Total moment of inertia</b> 2.0374 kgm <sup>2</sup>	<b>Power Factor 100%</b> 0.85
<b>Frequency</b> 60 Hz	<b>Start Current</b> 1,020 A	<b>Type of duty</b> S1	<b>Power Factor 75%</b> 0.81
<b>Max P2 (1x)</b> 137.43 kW	<b>Starting Current, Direct Starting</b> 1,020 A	<b>Stator Variant</b> 6	<b>Power Factor 50%</b> 0.71
<b>Number Of Poles</b> 4	<b>Starting Current, Star Delta</b> 340 A	<b>Motor Module</b> 110	<b>Efficiency 100%</b> 96.3 %
			<b>Efficiency 75%</b> 97 %
			<b>Efficiency 50%</b> 97.4 %
			<b>Cooling Jacket</b> Closed Loop Cooling System

## NP 3231/706 3~ 480 | Hydraulic Data & Performance Curve

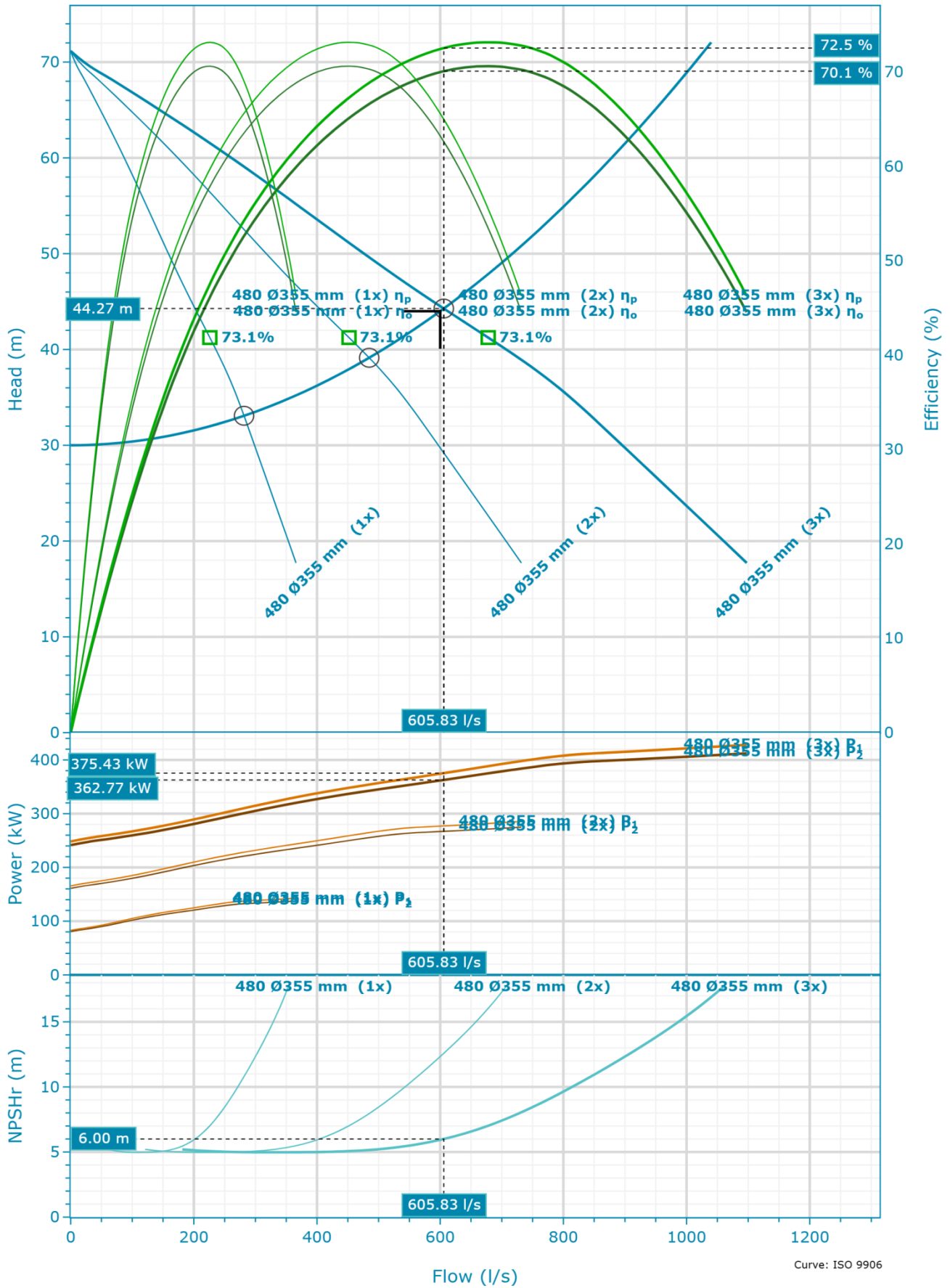

Nominal (mean) data shown. Under- and over-performance from this data should be expected due to standard manufacturing tolerances. Please consult your local Flygt representative for performance guarantees.

### Selection

Series	Curve Code
N 3000	480
Name	Impeller Diameter
NP 3231/706 3~ 480	355 mm

### Fluid

Fluid Type	Density
Water	1,000 kg/m <sup>3</sup>
Fluid Temperature	Dynamic Viscosity
4 °C	0.001567 Pa·s

Frequency 60 Hz	Inlet Diameter 250 mm	Specific Gravity 1	Fluid Vapor Pressure 8.135 mbar
Total Flow 600.00 l/s	Outlet Diameter 200 mm		
Total Head 44.00 m	Number Of Vanes 3		
Pump Flow 200.00 l/s			
Pump Head 44.00 m			
System Type Parallel Pumps			
Operating Pumps 3			
Standby Pumps No Standby Pump			

**Design Point - Single Pump**

Flow (1x) 201.94 l/s	Input Power (P1) (1x) 125.14 kW
Head (1x) 44.27 m	Shaft power (P2) (1x) 120.92 kW
Overall Efficiency (1x) 70.09 %	NPSHr (1x) 6 m
Pump Efficiency (1x) 72.53 %	Static Head 30.00 m
	Flow To BEP Ratio (1x) 89.4 %

**Design Curve - Single Pump**

Rated Speed 60 Hz	BEP Flow (1x) 225.98 l/s
Max Flow (1x) 365.89 l/s	BEP Head (1x) 41.24 m
H@QMin (1x) 71.15 m	Max P2 (1x) 137.43 kW
H@QMax (1x) 17.72 m	
BEP (1x) 73.1 %	

**Design Point - System**

Flow 605.83 l/s	Input Power (P1) 375.43 kW
Head 44.27 m	Shaft power (P2) 362.77 kW
Overall Efficiency ( $\eta_o$ ) 70.09 %	NPSHR 6 m
Pump Efficiency ( $\eta_p$ ) 72.53 %	Static Head 30.00 m
	Flow To BEP Ratio 89.4 %

**Design Curve - System**

Rated Speed 60 Hz	BEP Flow 677.93 l/s
Max Flow 1,097.68 l/s	BEP Head 41.24 m
H@QMin 71.15 m	Max P2 412.29 kW
H@QMax 17.72 m	Specific Energy 619,693 J/m <sup>3</sup>
BEP 73.1 %	

**NP 3231/706 3~ 480 | Duty Analysis**

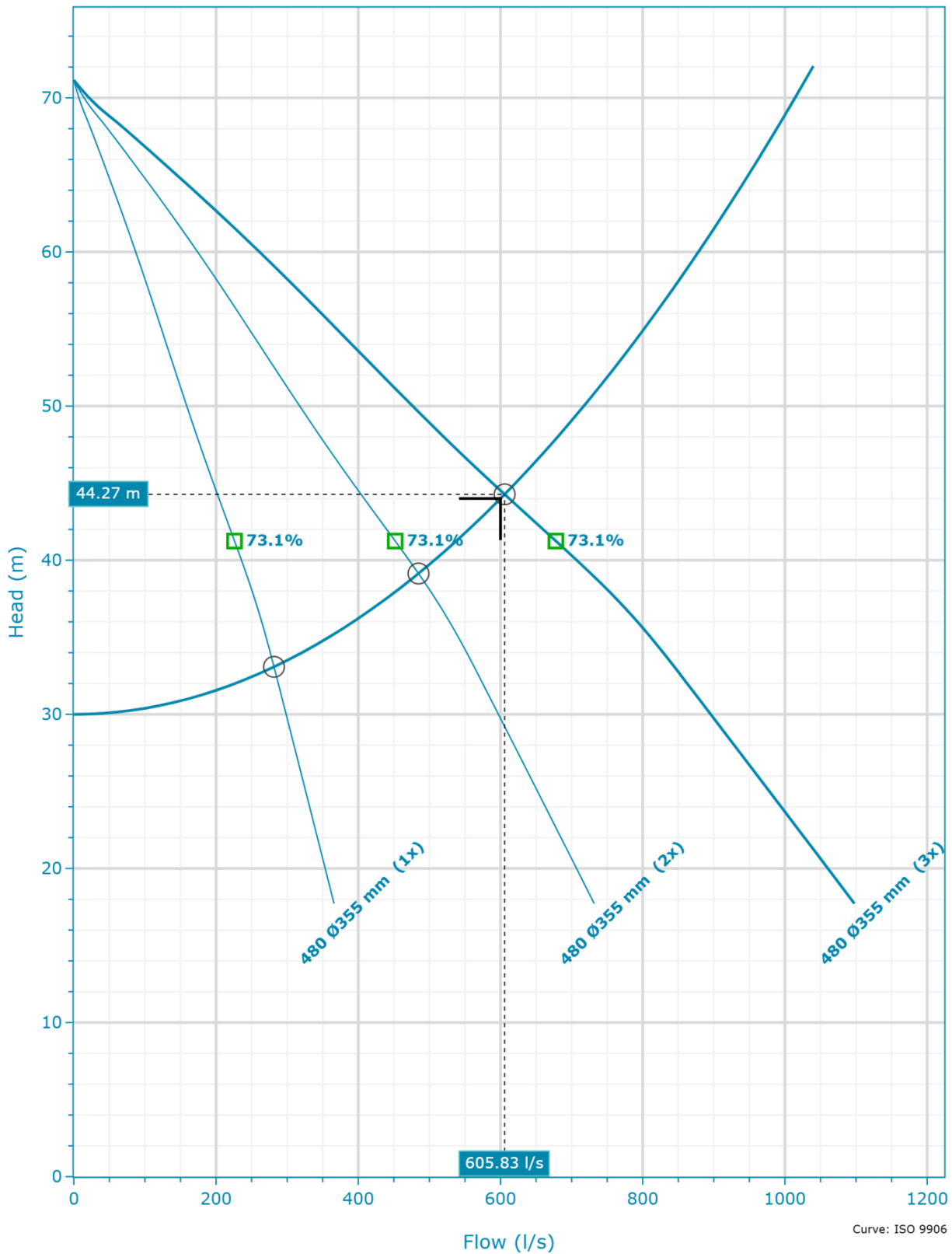

Nominal (mean) data shown. Under- and over-performance from this data should be expected due to standard manufacturing tolerances. Please consult your local Flygt representative for performance guarantees.

Name	Q (1x) [l/s]	H (1x) [m]	P2 (1x) [kW]	Q [l/s]	H [m]	P2 [kW]	$\eta_p$ [%]	SE [J/m <sup>3</sup> ]	NPSHr [m]
DP @ 1x	281.48	33.08	132.36	281.48	33.08	132.36	69.02	487,811.61	10.79
DP @ 2x	242.34	39.14	127.73	484.69	39.14	255.45	72.84	546,217.6	7.95

DP @ 3x	201.94	44.27	120.92	605.83	44.27	362.77	72.53	619,693.46	6
---------	--------	-------	--------	--------	-------	--------	-------	------------	---

**NP 3231/706 3~ 480 | Variable Speed Curve**

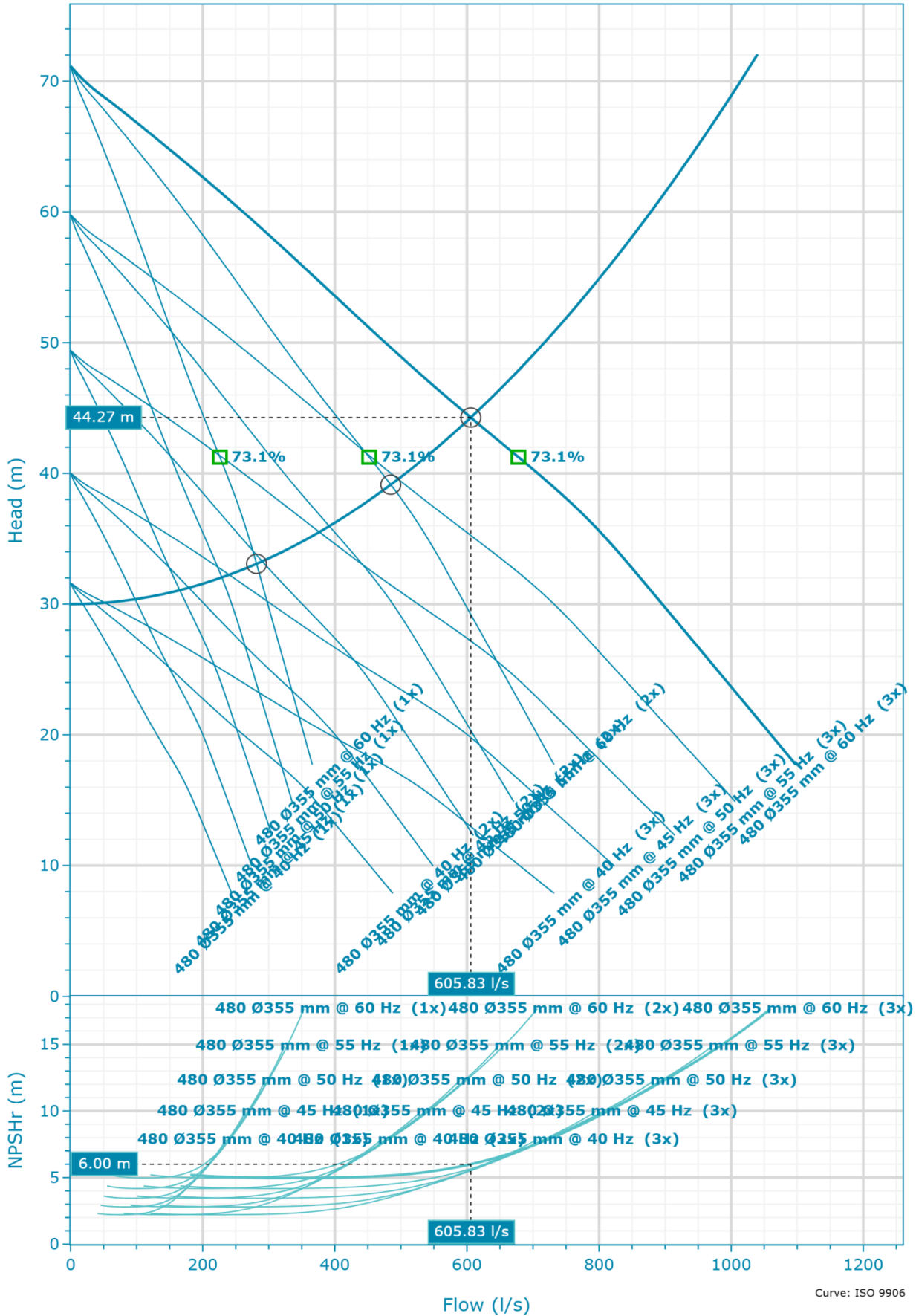

Nominal (mean) data shown. Under- and over-performance from this data should be expected due to standard manufacturing tolerances. Please consult your local Flygt representative for performance guarantees.

**NP 3231/706 3~ 480 | Variable Speed Analysis**

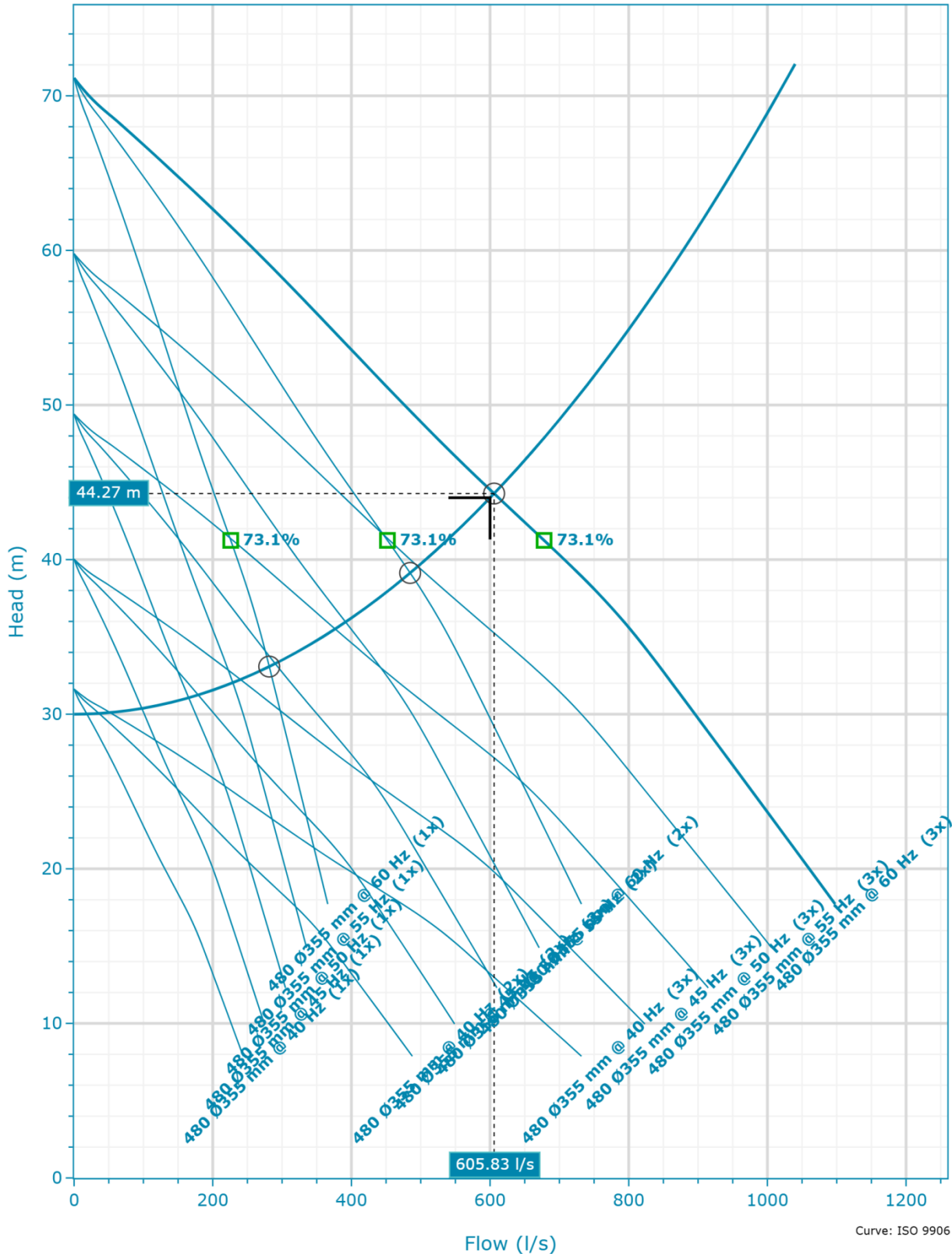

Nominal (mean) data shown. Under- and over-performance from this data should be expected due to standard manufacturing tolerances. Please consult your local Flygt representative for performance guarantees.

Name	Speed	Q (1x) [l/s]	H (1x) [m]	P2 (1x) [kW]	Q [l/s]	H [m]	P2 [kW]	ηp [%]	SE [J/m³]	NPSHr [m]
DP @ 1x	40 Hz	18.5	30.01	25.34	18.5	30.01	25.34	21.48	1,409,192.48	0.06
DP @ 1x	45 Hz	97.77	30.37	45.76	97.77	30.37	45.76	63.65	483,314.07	2.81

DP @ 1x	50 Hz	165.3	31.06	69.63	165.3	31.06	69.63	72.34	435,906.69	4.08
DP @ 1x	55 Hz	228.98	32.04	99.28	228.98	32.04	99.28	72.49	449,451.36	7.09
DP @ 1x	60 Hz	281.48	33.08	132.36	281.48	33.08	132.36	69.02	487,811.61	10.79
DP @ 2x	40 Hz	18.04	30.05	25.31	36.08	30.05	50.62	21	1,443,254.4 5	0.05
DP @ 2x	45 Hz	89.49	31.25	44.79	178.98	31.25	89.58	61.24	516,555.08	2.8
DP @ 2x	50 Hz	145.05	33.27	67.32	290.1	33.27	134.63	70.33	479,880.98	3.7
DP @ 2x	55 Hz	195.8	35.96	94.66	391.6	35.96	189.31	72.98	500,501.09	5.41
DP @ 2x	60 Hz	242.34	39.14	127.73	484.69	39.14	255.45	72.84	546,217.6	7.95
DP @ 3x	40 Hz	17.35	30.11	25.26	52.06	30.11	75.77	20.28	1,497,038.8 2	0.04
DP @ 3x	45 Hz	80.03	32.24	43.6	240.09	32.24	130.79	58.06	561,932.51	2.79
DP @ 3x	50 Hz	125.52	35.51	65	376.55	35.51	195.01	67.27	535,098.82	3.52
DP @ 3x	55 Hz	165.26	39.56	90.38	495.79	39.56	271.15	70.96	565,655.54	4.56
DP @ 3x	60 Hz	201.94	44.27	120.92	605.83	44.27	362.77	72.53	619,693.46	6

NP 3231/706 3~ 480 | Dimensional Data & Drawing

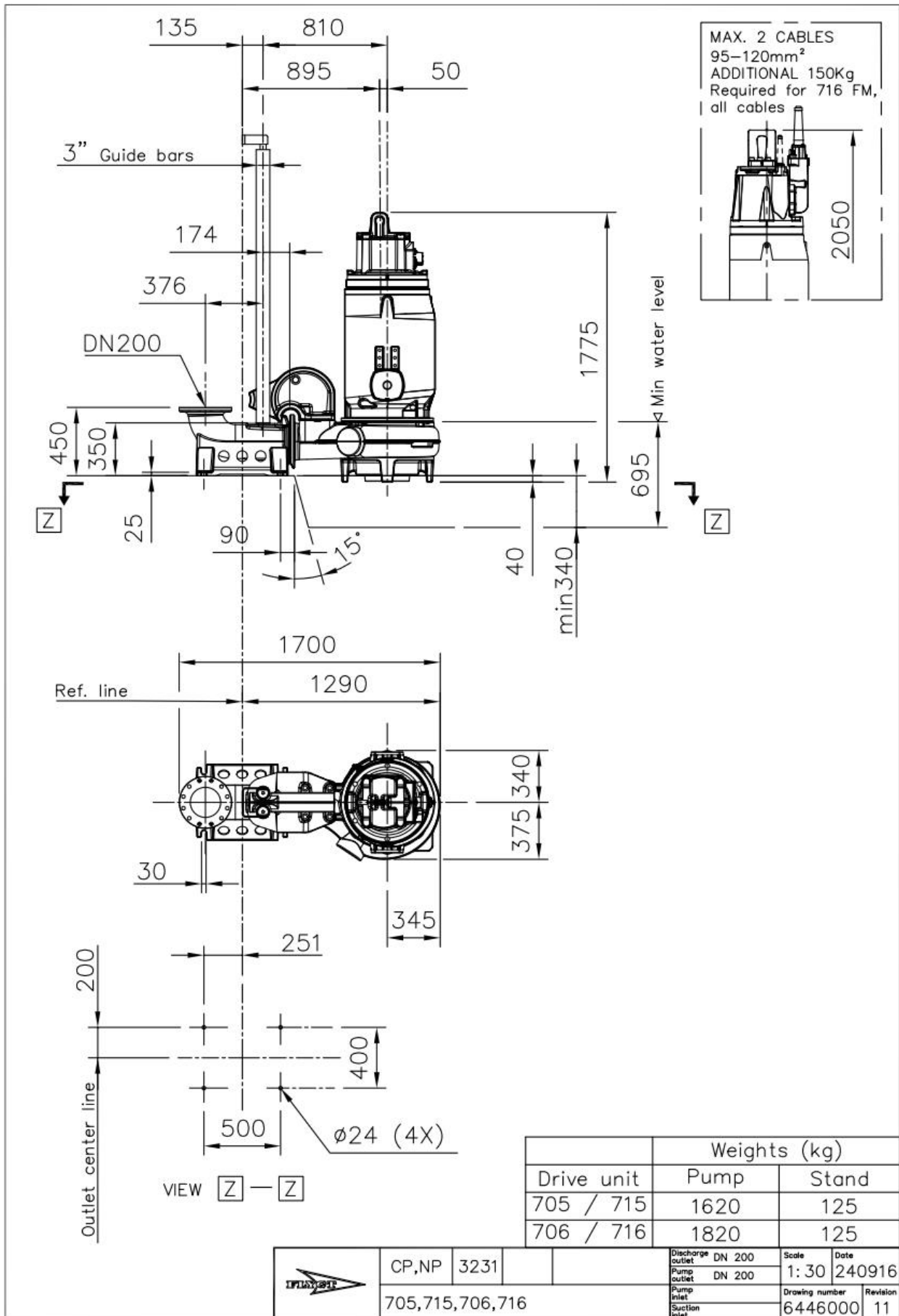

<b>Company</b>	Xylem
<b>Contact</b>	fabian Raymond
<b>Phone No.</b>	4163479950
<b>Email</b>	fabian.raymond@xylem.com